

TECHNICAL CATALOGUE

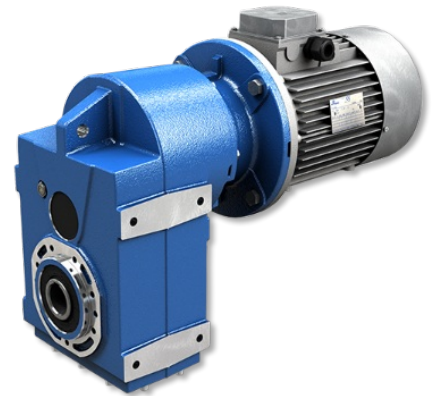

SHAFT MOUNTED GEARED MOTORS

STANDARD **IEC**

1. GENERAL INFORMATION

1.1	COMPANY PROFILE	4
1.2	PRODUCTS AND SOFTWARE MOTOVARIO	6
1.3	SYMBOLS AND FORMULAS	9
1.3.1	Symbols	9
1.3.2	Formulas	10
1.4	PRODUCT SELECTION	11
1.5	SERVICE FACTOR	12
1.6	INSTALLATION	13
1.6.1	Installation	13
1.6.2	Installation	13

2. PRODUCT INFORMATION

2.1	DESIGN FEATURES	14
2.2	TYOPOLOGY	15
2.2.1	Designation	15
2.2.2	Versions	16
2.2.3	Modularity	17
2.3	MOUNTING POSITIONS	18
2.3.1	Mounting positions	18
2.3.2	Position of terminal box	18
2.4	THERMAL POWER	19
2.4.1	Information	19
2.4.2	Verification	19
2.5	CRITICAL APPLICATIONS	20
2.5.1	Critical applications	20
2.5.2	Information	20
2.6	MOTOR FLANGE AVAILABILITY	21
2.7	OUTPUT SHAFT BEARINGS	25
2.8	OVERHUNG LOAD	26
2.8.1	Information	26
2.8.2	Input	26
2.8.3	Output	27

2.9	LUBRICATION	28
2.9.1	Information	28
2.9.2	Lubricants	28
2.9.3	Special lubricants	29
2.9.4	Quantity	30
2.10	MOMENTS OF INERTIA	31

3. DIMENSIONS

3.1	REDUCERS/GEARED MOTORS	32
3.1.1	S 052...123	32
3.1.2	S 142...153	33
3.1.3	CS 052...123	34
3.1.4	IS 052...123	36
3.1.5	IS 142...153	37
3.2	WEIGHTS	38
3.3	SHAFT END	39
3.4	ELECTRIC MOTORS	40
3.4.1	Electric motors	40
3.4.2	Standard high efficiency (TS), high (TH) and premium (TP) motors	42
3.4.3	Nominal power - [kW]	42

4. ACCESSORIES AND OPTIONS

4.1	LOW SPEED SHAFTS	43
4.2	OUTPUT FLANGE	44
4.3	SHAFT MOUNTING FASTENING	45
4.3.1	Reaction bolt	45
4.3.2	Torque arm - S 142...153	45
4.4	BACKSTOP DEVICE	46
4.5	OUTPUT SHAFT WITH SHRINK DISC	47
4.6	REINFORCED OIL SEALS FOR OUTPUT SHAFT	48
4.7	ASSEMBLING/DISASSEMBLING KIT	49
4.8	MACHINE AXIS	50

5. PERFORMANCES

5.1	S GEARED MOTORS (50Hz)	51
5.2	IS GEAR REDUCER - 1750 rpm	126
5.3	IS GEAR REDUCER - 1400 rpm	134
5.4	IS GEAR REDUCER - 1140 rpm	142
5.5	IS GEAR REDUCER - 900 rpm	150
5.6	IS GEAR REDUCER - 700 rpm	158
5.7	IS GEAR REDUCER - 500 rpm	166

6. SALES CONDITIONS

6.1	SALES CONDITIONS	174
-----	------------------	-----

Motovario® corporate philosophy aims to promote the company's brand and products at an international level with determination and transparency, while constantly striving to offer innovative solutions for satisfying and anticipating the demand of the market. Motovario® provides technologically advanced solutions in the transmission components field for industrial and civil applications worldwide.

The company

At Formigine, the heart of Modena's industrial district, Motovario® boasts a production plant spanning 50,000 m² that employs 500 people.

1965 Foundation of Motovario

1998 Acquisition of Spaggiari Trasmissioni, an important brand in the mechanical technology sector.

2006 Motovario acquisition by a private investment fund managed by Synergo SGR, in order to guarantee its development and support its expansion throughout the world.

2014 Acquisition of Pujol.

2015 Acquisition by TECO.

At the core of Motovario® lies an evolved production process based on technological solutions that convert power into movement. Motovario® is at the heart of the production processes that drive industries worldwide. Quality and reliability are the company's fundamental assets. Motovario® is present throughout the world with branches in France, Spain, Germany, England, China, the United States and India. The sales network and customer service guarantee immediate and high-quality support to all customers. In addition, the company boasts a worldwide network of MAC (Motovario Assembly Centre). Qualified assembly centres are present, in Italy, Australia, Benelux, Bulgaria, China, Finland, France, India, Ireland, Israel, Malaysia, Poland, Portugal, South Korea, Spain, Sweden, Turkey, United Kingdom, Ukraine and USA. The company is able to offer a wide range of products: speed variators, right-angle, helical-bevel, shaft-mounted, worm gear reducers and gearmotors, electric motors, inverter and inverter drives. Maximum quality and precision are ensured by the cutting-edge technologies implemented in the production process. 170 numerical control machines, served by LGV lines for storage in automatic warehouses, ensure a high standard of efficiency for the Motovario® production department.

The highly automated assembly lines are supported by a specific computerised system. The process statistical control system manages the production process to avoid rejects, by enabling the operator to monitor all the processing phases. The annealing, tempering, hardening and carburizing treatments are carried out inside the plant. The plant operates on a 24-hour basis, including holidays. Reliability, resilience and versatility are the distinctive features of Motovario® products, the most qualified solution to any power transmission requirement.

Main fields OF APPLICATIONS

- Mechanical-electromechanical industry (car washing, pumps, barriers & automatic doors, circuit breakers)
- Ceramic industry (ovens, press feeding systems)
- Food, farming, oenology industry
- Wood, marble, glass industry
- Packaging & bottling industry
- Textile, shoes, leather industry
- Transport, logistic industry
- Construction industry
- Milling, animal husbandry, flower industry
- Machine tools & steel industry
- Mining, quarry, cement industry
- Energy industry (solar, nuclear, biomass, wind)
- Amusement industry (theatres, leisure parks, kiddy rides)
- Chemical & pharmaceuticals industry
- Paper & printing industry
- Plastic & rubber industry
- Telecommunications industry (satellite orientation systems, military radar)
- Engineering and consultant companies

Certifications

Our products can be manufactured to conform with the ATEX Directive 2014/34/UE. In addition, the safety and quality of our motors, geared motors and motovariators is guaranteed by the EAC (EurAsian Conformity) certification, an essential requirement for products exported to the Russian Federation. Our motors are UL certified, which guarantees their safety and quality requirements for the North American market.

Quality CONCEPT

Motovario® has obtained the quality certification renewal of its production system in conformity to the UNI EN ISO 9001:2008 standard. This internationally recognised certification acknowledges the company's commitment and drive geared towards constantly improving products, projects and services offered. Moreover, the company has obtained the OHSAS 18001:1999 (Occupational Health and Safety Assessment Series) certification, which defines the requirements of the workplace safety and health management system.

Research & DEVELOPMENT

Technological innovation: a crucial factor for competing in the market. In the company's 50-year history, research and change have been the pivotal factors in guaranteeing competitiveness at a global level, thanks to increasingly advanced products in terms of performance and reliability. Each year the company invests an increasing amount of its turnover in research and development, geared towards promoting the constant study and analysis of products, control processes and performance certification. In order to ensure that customers receive products that comply with the requested performance levels, the company carries out simulations on all new products, including NVH (Noise, Vibration, Harshness) tests effected in the advanced semi-anechoic chamber.

Customer CARE

Innovative instruments and software applications supporting the technical and logistic requirements of our partners worldwide guarantee a timely and customised service. The experience acquired by Motovario® has led to the creation of the new online portal MyMotovario 4.0, which allows for selecting products and exporting their 3D file. As a result, designers and engineering departments can download the three-dimensional model of the requested product and implement it directly in their own layout. In order to maximise customer service and quality, Motovario® offers all its customers the following online services: Order Tracking, which allows for monitoring the progress of an order in real time, and the Stock Availability service, through which users may check the availability (stock) of our products, both in the Italian plant and in the various branches.

Motovario chooses technological evolution.

Motovario® has chosen technological evolution and actively collaborates with the Faculty of Engineering of the University of Modena and Reggio Emilia and of the University of Bologna.

Reliability, sturdiness, versatility

These are the distinctive traits of Motovario products. A broad range of transmission products that provide a competent, innovative solution to each and every power application need. Cutting-edge tools, unrelenting research efforts and ongoing commitment to upgrading manufacturing equipment to the latest state-of-the-art enable us to offer high quality and performance standards to cater to industry requirements and the broadest variety of applications. Motovario ranks among the leading, well-reputed companies in Italy engaged in the design, manufacture and sales of transmission products for industrial and civil applications. The entire manufacturing process takes place in Formigine and Ubersetto plants, in Modena area, with an overall surface area of over 50.000 sq m. and a workforce of about 500 people. 170 numerically controlled machines and cutting-edge handling, storage and assembly automated systems ensure that all products meet high quality standards. The network includes more than 40 Motovario-certified assembly centres, with the capability to supply products in a broad range of versions, including customised versions, high service capacity and fast response. As a result, our product offering can cater to the needs of all plant engineering sectors, in all industries and for different applications, and includes: speed variators, helical, bevel-helical, parallel helical, worm gear reducers and gearmotors, electric motors and motor-inverters. All of the products we manufacture share such common features as reliability, sturdiness and versatility, topped with a high innovation content. At the heart of a company's technological innovation is the ability to develop integrated tools for computer-aided calculation simulation and management of different processes as part of product development. When simulating operating, setup and process conditions, it is also necessary to analyse and optimize the overall functional design of a product using a synergistic approach. This is achieved by implementing an exhaustive experimental plan, without using interpolation or approximation, as they frequently allow criticalities or any oversizing which is not conducive to maximising quality/cost ratio to go unnoticed.

High-efficiency method for calculation according to standards

A set of specific functions have been developed to this end. A few significant examples include functions to:

- Optimise individual reduction ratios and the combinations of the different reduction stages based on parametrisable target normal series;
- Calculate torque values and maximum permissible external forces for gear reducer units, using iterative numeric algorithms to confirm target life/safety values of components;
- Create databases for loading a FEM structural analysis model by automatically writing all reaction components of bearings under all load conditions to a specific file, with automatic selection of critical cases that need to be verified.

Another goal of the method is to create synergy between calculation according to standards and FEM structural calculation and the implementation of FEM model loading procedures, so as to simplify input data, meshing and constraint criteria

Competitiveness and operational benefits of the new method

This method offers many practical advantages over traditional calculation procedures within the company, namely:

- Iterative optimisation of project since setup stage;
- Accurate assessment of the various service factors and reliability levels for the entire gear reducer unit and for all operating conditions as per catalogue rating or customer specific requirements;
- Faster support to customers in analysing tailored product configurations;
- Integrated corporate databases that can be updated in real-time.

Range extension and ongoing evolution

The steady, significant growth of Motovario Group is achieved thanks to an ongoing search for new calculation and design tools, as well as to customer service. The new tools identified have led to innovation, improved product reliability as well as positive developments in market management. The following software products are used for design, calculation and management:

- Solidworks;
- Kissoft;
- Kissys;
- Ansys;
- FEM modelling analysis software;
- Circuit design and simulation software;
- Specific spreadsheets;
- SAP.

In MyMotovario 4.0 portal, PRODUCT SELECTION includes a section named APPLICATIONS where customers can enter application data and find out which gear reducer suits them best in a matter of minutes.

MOTOVARIO Products

HELICAL GEAR REDUCERS

Cast iron or aluminum casing
 Output shaft up to 90 mm
 Mn₂ up to 8.600 Nm
 Reduction stages 1, 2, 3
 Ratios up to 354
 Atex units

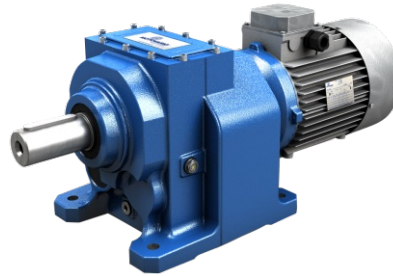
**HELICAL BEVEL GEAR REDUCERS**

Cast iron or aluminum casing
 Output shaft up to 110 mm
 Mn₂ up to 14.000 Nm
 Reduction stages 2, 3
 Ratios up to 443
 Atex units

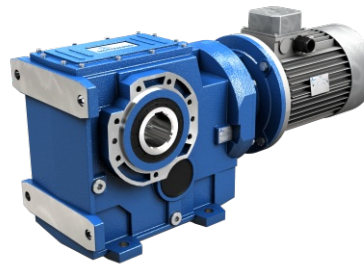
**SHAFT MOUNTED GEAR REDUCERS**

Cast iron
 Output shaft up to 90 mm
 Mn₂ up to 10.250 Nm
 Reduction stages 2, 3
 Ratios up to 395
 Atex units

**WORM GEAR REDUCERS**

Cast iron or aluminum casing
 Output shaft up to 50 mm
 Mn₂ up to 2.700 Nm
 Ratios up to 1083
 Atex units



PARALLEL HELICAL AND BEVEL HELICAL GEAR REDUCERS FOR MIDDLE HEAVY INDUSTRY

Cast iron casing
Output shaft up to 180 mm
Mn₂ up to 110.000 Nm
Reduction stages 1, 2, 3, 4
Ratios up to 636
Atex units

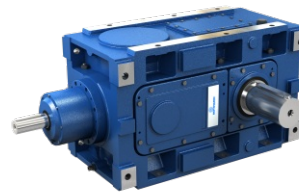
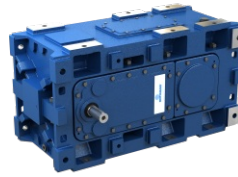
**MOTOVARIATORS AND MOTOVARIATOR-GEAR REDUCERS**

Cast iron or aluminum casing
Ratios infinite
Mn₂ up to 5.000 Nm
Atex units

**ELECTRIC MOTORS**

Power ratings up to 90 kW
Poles 2, 4, 6
Three-phase and single-phase, built-in brake, dual polarity
Protection class up to IP66

**DRIVES****DRIVON - motoinverter**

Three phase and single phase power supply
High dynamics sensorless vectorial control
Power ratings up to 5,5 kW
Standard integrated STO
Integrated field bus
Optional field bus



1.3.1 Symbols

Physical dimension	Symbol	Symbol units of measure	Input	Output
Power	P	[kW]	P ₁	P ₂
Requested power	Pr	[kW]	Pr ₁	Pr ₂
Nominal power	Pn	[kW]	Pn ₁	Pn ₂
Torque	M	[Nm]	M ₁	M ₂
Nominal torque	Mn	[Nm]		Mn ₂
Requested torque	Mr	[Nm]	Mr ₁	Mr ₂
Speed	n	[rpm]	n ₁	n ₂
Force	F	[N]		
Radial load	Fr	[N]	Fr ₁	Fr ₂
Axial load	Fa	[N]	Fa ₁	Fa ₂
Reduction ratio	i			
Dynamic efficiency	η_d			
Service factor	f.s.			
Static	s			
Dynamic	d			
Calculated	c			
Maximum	max			
Minimum	min			
Moment of inertia	J	[kgm ²]	J ₁	
Ambient temperature	T _{amb}	[°C]		
Dimension		[mm]		

1.3.2 Formulas

REDUCER		
Starting or stopping time	$t = v / a$	[s]
Velocity in rotary motion	$v = \pi * d * n / 60$ $v = \omega * r$	[m/s]
Speed velocity Angular velocity	$n = 60 * v / (\pi * d)$ $\omega = v / r$	[rpm] [rad/s]
Acceleration or deceleration according to a starting / stopping time	$a = v / t$	[m/s ²]
Angular acceleration	$\alpha = n / (9,55 * t)$ $\alpha = \omega / t$	[rad/s ²]
Starting or stopping distance (according to acceleration / deceleration or angular velocity)	$s = a * t^2 / 2$ $s = v * t / 2$	[m]
Horizontal translation force	$F = \mu * m * g$	[N]
Vertical translation force (lifting)	$F = m * g$	
Inclined plane translation force	$F = m * g (\mu * \cos\beta + \sin\beta)$	
m= mass [kg]; g= gravity acceleration [m/s ²]; μ = friction coefficient; β = angle of inclination		
Moment of inertia	$J = m * v^2 / \omega^2$	[kgm ²]
Torque	$M = F * d / 2$ $M = J * \omega / t$	[Nm]

MOTOR and GEARMOTOR		
Starting time	$t_a = (J_{ext} + J_m) * n_n / 9,55 + (M_{peak} - M_r)$	[s]
Braking time	$t_s = (J_{ext} + J_m) * n_n / 9,55 + (M_{peak} + M_r)$	[s]
Motor rotation angle during starting	$\varphi = n_n * t_a / 19,1$	[rad]
Motor rotation angle during braking	$\varphi = n_n * t_s / 19,1$	[rad]
Power available at the shaft of single phase motor	$P = V * I * \eta * \cos\omega$	[W]
Power available at the shaft of three phase motor	$P = 1,73 * V * I * \eta * \cos\omega$	[W]

RUNNING at 60Hz		
Speed velocity at 60Hz	$n_{60Hz} = 1,2 * n_{50Hz}$	[rpm]
Power at 60Hz	$P_{1\ 60Hz} = P_{1\ 50Hz} * V_{60Hz} / V_{50Hz}$	[kW]
If input voltage at 60 Hz (V_{60Hz}) corresponds to winding voltage at 50 Hz (V_{50Hz}), power doesn't change $P_{1\ 60Hz} = P_{1\ 50Hz}$		
If input voltage at 60 Hz (V_{60Hz}) is 20% higher than winding voltage at 50 Hz (V_{50Hz}), power increases by 20% $P_{1\ 60Hz} = 1,2 P_{1\ 50Hz}$		
Torque at 60Hz	$M_{60Hz} = M_{50Hz} * P_{1\ 60Hz} / (1,2 * P_{1\ 50Hz})$	[Nm]
Service factor at 60Hz	$f.s_{60Hz} = f.s_{50Hz} * 1,175 * P_{1\ 50Hz} / P_{1\ 60Hz}$	-

For correctly selecting a gear reducer or geared motor, several essential pieces of data are required:

1. The rotational input speed to the gear reducer (n_1) and the rotational output speed (n_2). Through these two values it is possible to calculate the reduction ratio (i) of the gear reducer using the following formula: $i = n_1/n_2$
2. The torque required by the application (Mr_2).

The geared motor or gear reducer can be selected once this data is known.

This guide helps you to select the right product in just a few steps:

Geared motor selection

1. Determine the application's actual service factor (**s.f.**). This parameter depends on the type of load of the powered machine, the number of starts per hour and the hours of operation (refer to the "Service factor" paragraph).
2. Calculate the input power Pr_1 using the required torque value Mr_2 , the speed n_2 and dynamic efficiency value. $Pr_1 = (Mr_2 * n_2) / (9550 * \eta_d)$. The dynamic efficiency value depends on the type of gear reducer and on the number of gear reduction stages. (To calculate the efficiency value see its page).
3. Consult the geared motor performance tables and identify a normalised power value Pn_1 exceeding the required power Pr_1 , such that: $Pn_1 \geq Pr_1$
4. Once the suitable nominal power has been identified, select the geared motor capable of generating the rotational speed closest to the desired n_2 value and with service factor s.f. greater or equal to that required by the application.

In the geared motor selection tables the combinations include 2-pole, 4-pole and 6-pole motors powered at 50Hz.

Gear reducer selection

1. Determine the application's service factor (**s.f.**) (consult to the "Service factor" paragraph on its page).
2. Calculate the reduction ratio i from the requested output speed n_2 and from the input speed n_1 . $i = n_1/n_2$
3. Calculate the torque Mc_2 for selecting the gear reducer through the torque required by the application Mr_2 and the service factor s.f.: $Mc_2 = Mr_2 * (s.f.)$
4. Consult the Gear Reducer Performance tables looking for the reducer that, with the reduction ratio closer to the calculated one, has a nominal torque Mn_2 so that: $Mn_2 \geq Mc_2$

Checks

Once the gear reducer or geared motor has been selected, the following checks should be performed:

A. Thermal power

The gear reducer's thermal power must be equal to or greater than the installed mechanical power, or the power required by the application according to the indications contained in the section (refer to the "Thermal power" paragraph).

B. Maximum torque

Generally, the maximum torque (peak instantaneous load) that can be applied to the gear reducer must not exceed 200% of the nominal torque Mn_2 (ATEX - M_{2max}).

C. Radial loads

1. Verify that the radial loads acting on the input and/or output shafts are within with the values indicated in the catalogue. If they exceed these values, increase the size of the gear reducer or modify the external load capacity. During the checking phase, it is important to remember that the values indicated in the catalogue refer to loads acting on the mid-point of the shaft protrusion, therefore, if the load is applied to a different position, appropriate formulas must be used to calculate the admissible load in the desired position (refer to the "Radial loads" paragraph).
2. If accessory output shafts are present, make sure that the applied load is compatible with shaft size. If help is needed: contact MOTOVARIO TECHNICAL SERVICE.

D. If an electric motor is going to be fitted to the selected gear reducer, check for its applicability by referring to the configuration table (see paragraph "Motor flange availability"). From IEC 180 motors, verify if necessary to support the motor with feet. In case of need please contact MOTOVARIO TECHNICAL SERVICE.

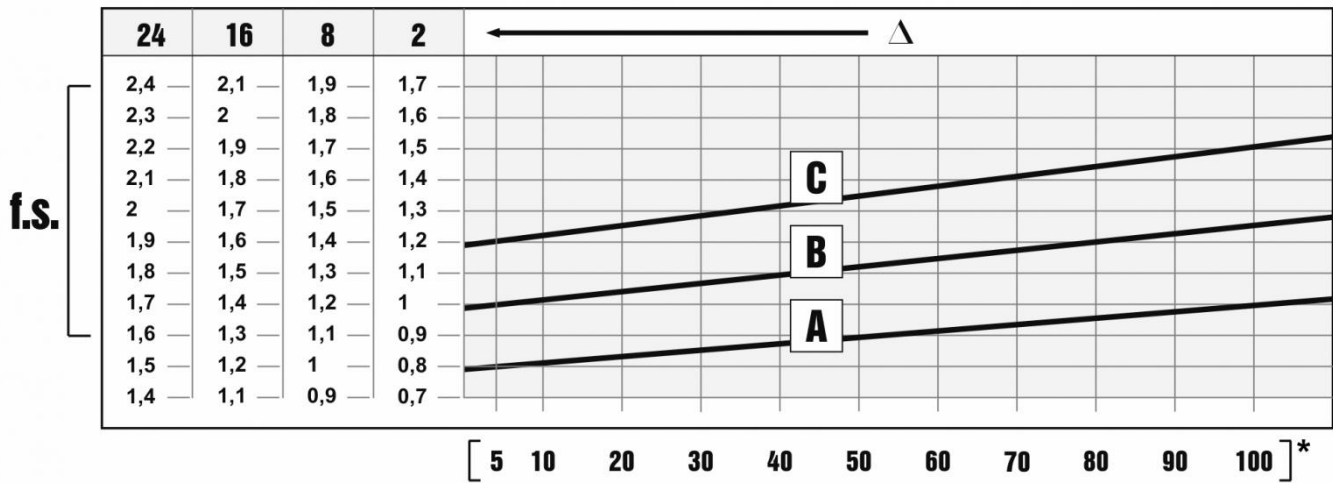

The service factor (f.s.) depends on the operating conditions the gear reducer is subjected to.

The parameters that need to be taken into consideration to select the most adequate service factor correctly comprise:

- type of load of the operated machine : A - B - C
- length of daily operating time: hours/day (Δ)
- start-up frequency: starts/hour (*)

LOAD:

- **A** - uniform = $f_a \leq 0,3$
- **B** - moderate shocks = $f_a \leq 3$
- **C** - heavy shocks = $f_a \leq 10$

$f_a = J_e/J_m$

- J_e [kgm^2] moment of reduced external inertia at the drive-shaft
- J_m [kgm^2] moment of inertia of motor

If $f_a > 10$ call MOTOVARIO TECHNICAL SERVICE.

In the case of a variable speed reducer, once determined the service factor of the application it is necessary to compare this value with the safety factor of the S reducer reported in the selection tables, verifying $S \geq f.s.$ condition. The maximum number of admissible starts depends on the type of application. Approximately, the figure must not exceed 5-10 for minute. Contact MOTOVARIO TECHNICAL SERVICE if you have any special requirements.

- Screw feeders for light materials, fans, assembly lines, conveyor belts for light materials, small mixers, lifts, cleaning machines, fillers, control machines.
- Winding devices, woodworking machine feeders, goods lifts, balancers, threading machines, medium mixers, conveyor belts for heavy materials, winches, sliding doors, fertilizer scrapers, packing machines, concrete mixers, crane mechanisms, milling cutters, folding machines, gear pumps.
- Mixers for heavy materials, shears, presses, centrifuges, rotating supports, winches and lifts for heavy materials, grinding lathes, stone mills, bucket elevators, drilling machines, hammer mills, cam presses, folding machines, turntables, tumbling barrels, vibrators, shredders.

1.6.1 Installation

To install the gear reducer it is necessary to note the following recommendations:

- Check the correct direction of rotation of the gear reducer output shaft before fitting the unit to the machine.
- In the case of particularly lengthy periods of storage (4/6 months), if the oil seal is not immersed in the lubricant inside the unit, it is recommended to change it since the rubber could stick to the shaft or may even have lost the elasticity it needs to function properly.
- Whenever possible, protect the gear reducer against solar radiation and bad weather.
- Ensure the motor cools correctly by ensuring good passage of air from the fan side.
- In the case of ambient temperatures $< -5^{\circ}\text{C}$ or $> +40^{\circ}\text{C}$ call MOTOVARIO TECHNICAL SERVICE.
- The various parts (pulleys, gear wheels, couplings, shafts, etc.) must be mounted on the solid or hollow shafts using special threaded holes or other systems that anyhow ensure correct operation without risking damage to the bearings or external parts of the units. Lubricate the surfaces in contact to avoid seizure or oxidation.
- Painting must definitely not go over rubber parts and the holes on the breather plugs, if any.
- For units equipped with oil plugs, replace the closed plug used for shipping with the special breather plug.
- Check the correct level of the lubricant through the indicator, if there is one.
- Starting must take place gradually, without immediately applying the maximum load.
- When there are parts, objects or materials under the motor drive that can be damaged by even limited spillage of oil, special protection should be fitted.

1.6.2 Installation

Assembling motor on pam flange

When the unit is supplied without motor, it is necessary to follow these recommendation to ensure the correct assembly of the electric motor. Check that the tolerances for the motor shaft and flange correspond to the "standard". Carefully clean the shaft, spigot and surfaces of the flange removing traces of paint and dirt, and confirm the key is fitted correctly. Fit the half coupling/sleeve to the motor shaft (see picture) taking care to ensure the motor shaft and bearings are not damaged by avoiding excessive force and where necessary using assembly equipment. Place the couplings elastic element onto the motor half coupling and position the motor up to the gear unit ensuring the coupling element is aligned with the driven half coupling. Complete the assembly using the fixing bolts. Key-ways with tightened tolerances.

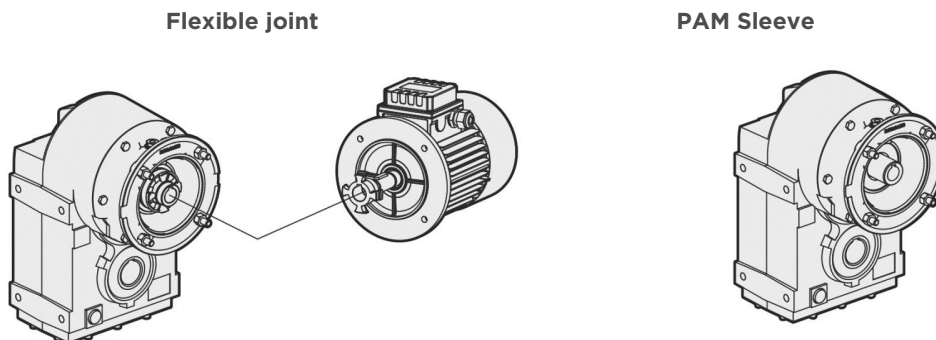

Motovario products are supplied with the following surface treatment features:

Grey-coloured cast-iron cases for gears

- Die-cast materials are always painted.

Grey-coloured cast-iron inspection cover: The gear reducer S... series with 2, 3 stages size 125, 140, 150 are supplied with grey-coloured cast-iron closing cover and a metal nameplate printed.



Painting specifications:

- Orange-peel blue epoxy-polyester RAL 5010. Polyester resin based heat-hardening powders, altered with epoxy resins.

Mechanical properties: Tests carried out onto degreased Unichim white lattens (film thickness: 60 microns) comply with the following specifications: adherence (ISO2409).

Heat resistance: 24 HOURS AT 150°C.

Corrosion strength: ASTM B 117/97 salt fog from 100 to 500 hours depending on the support's preliminary treatment.

Performance:

- Loading capacity in accordance with DIN 3990, ISO 6336, AGMA 2101, ISO 10300, DIN 3991, ISO 281, DIN 743.

Efficiency η :

- The efficiency is the ratio between the output power P_2 and the power absorbed by the gear reducer P_1 : $\eta = P_2/P_1$.

S-range shaft-mounted reducers have an average value equal to:

S..2 stages = 0,96

S..3 stages = 0,94

2.2.1 Designation

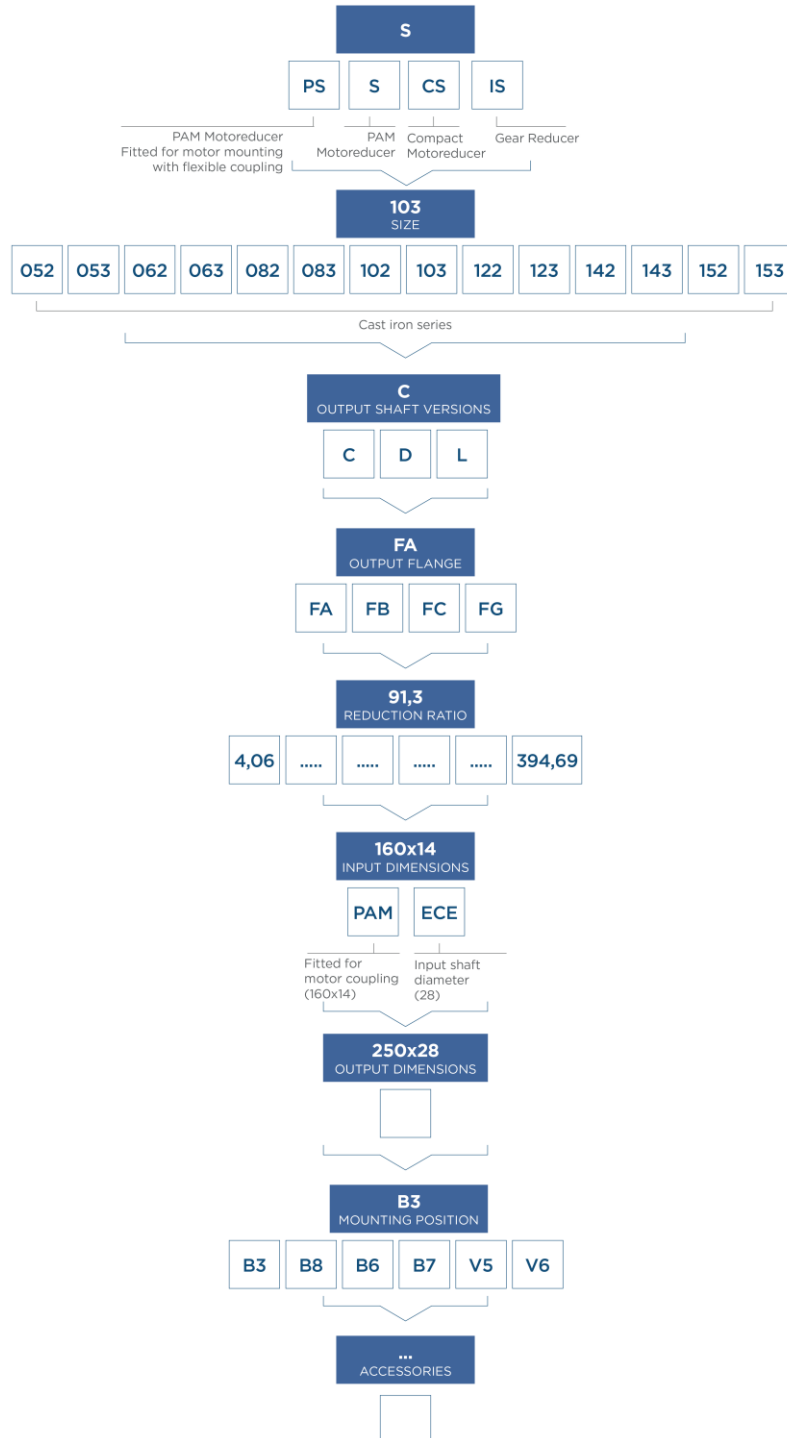

2.2.2 Versions

S... C - S... D - S... L

S.. C FOOT-FLANGE MOUNTING / HOLLOW SHAFT

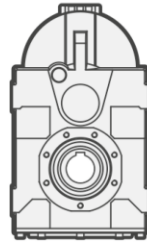
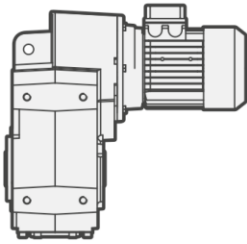

S.. D FOOT-FLANGE MOUNTING / D SOLID SHAFT

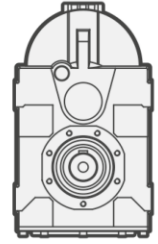
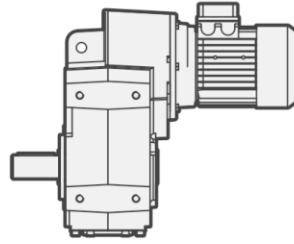

S.. L FOOT-FLANGE MOUNTING / SHRINK DISC SHAFT

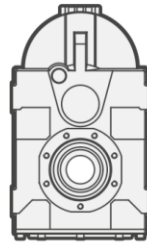
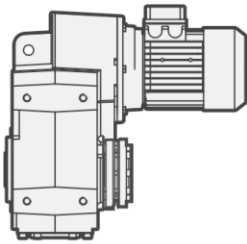

2.2.3 Modularity

S GREY CAST IRON SERIES

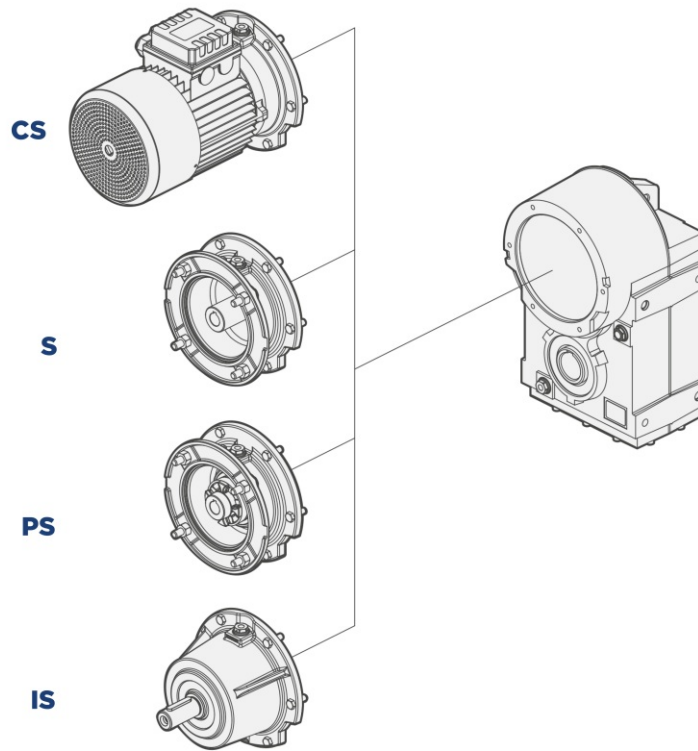

CS
Compact electric motor versions

PS
Fitted for motor mounting
with flexible coupling

S
Fitted for motor coupling version
(PAM)

IS
Input shaft versions

2.3.1 Mounting positions

The mounting position of the gear unit identifies its space orientation. B3 mounting position, as from a technical point of view, ensures lower oil splash, better lubrication and less heating.

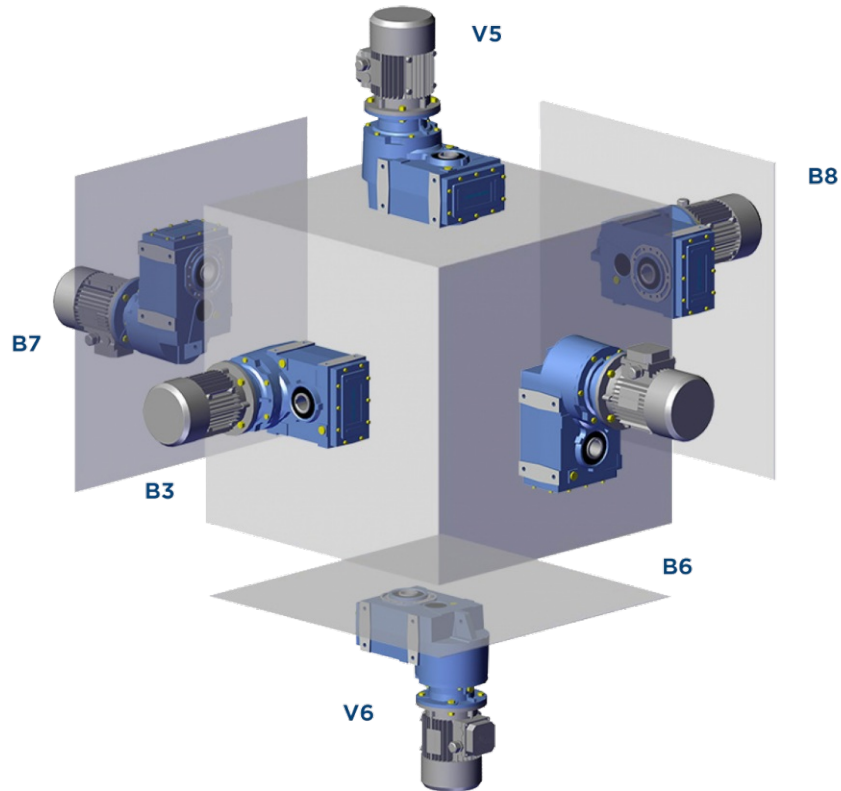

2.3.2 Position of terminal box

Unless otherwise specified when ordering, the gear reducer is supplied with terminal box in position 1.

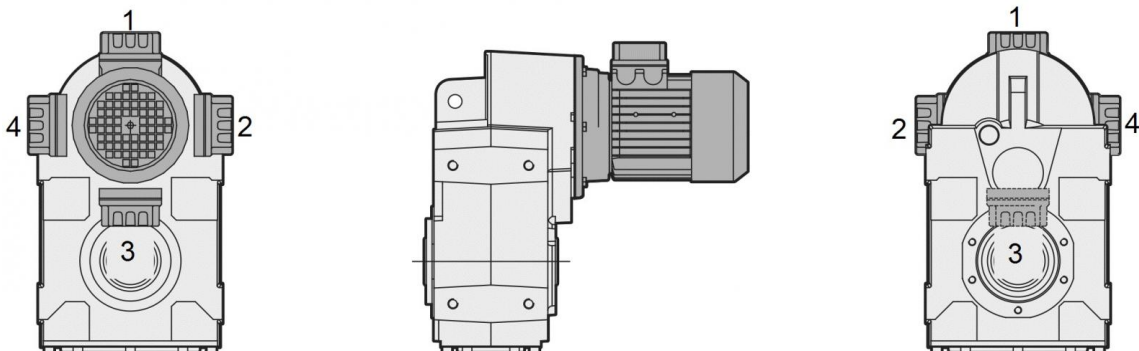

2.4.1 Information

The scheme below indicates the nominal thermal power Pth capacity [kW] according to the following conditions:

- mounting position B3
- continuous operation at input speed ≤ 1500 rpm
- environment temperature $T_{amb}=25^{\circ}\text{C}$
- sea level altitude
- air speed around the gear reducer $\geq 1\text{m/s}$
- absence of external radial and/or axial loads

$n_1=1500\text{rpm}$	
	Pth [kW]
S052	7
S062	9,5
S082	15,5
S102	20,5
S122	34,5
S142	53
S152	65

A correct lubrication and a proper running condition of the gearbox are guaranteed only applying an input power not exceeding Pth (at the above reference conditions)(T oil max=95°C).

NOTE: Normally, three stages gearboxes do not require thermal power verification because the thermal rating usually exceed the mechanical one.

2.4.2 Verification

Application check

Except for continuous operating times below two hours and successive pauses capable of bringing the gear reducer back to ambient temperature, for each application it is peremptory to verify the gear reducer's thermal limit according to the following formula: $P_1 < P_{th} * F_c * F_v * F_a$, where:

- P_1 = input power to the gear reducer [kW]
- P_{th} = thermal power at the reference conditions [kW] (see above table)
- F_c = ambient and operating temperature correction factor
- F_v = ventilation correction factor
- F_a = altitude correction factor

The correction factors refer to different operating conditions compared to the reference conditions, and are provided by the following ISO14179 tables:

Ambient temperature °C	F_c	Duty per hour of operation %				
		100	80	70	40	20
10	1,15	1,21	1,32	1,55	2,07	
18	1,07	1,12	1,23	1,44	1,93	
25	1,00	1,05	1,15	1,35	1,80	
30	0,93	0,98	1,07	1,26	1,67	
40	0,83	0,87	0,95	1,12	1,49	
43	0,75	0,79	0,86	1,01	1,35	
50	0,67	0,70	0,77	0,90	1,21	

Altitude [m]	F_a
0*	1
750	0,95
1500	0,9
2250	0,85
3000	0,81

Ventilation correction factor	F_v
Stagnant air (<0,5 m/s)	0.75
Indoor installation with slight ventilation	1
Indoor installation with good ventilation (>1,4 m/s)	1.4
Outdoor installation (>3,7 m/s)	1.9

*Sea level

In case of operation at input speeds exceeding 2000 rpm, or ambient temperatures greater than 40°C, it is advisable to contact our technical department.

2.5.1 Critical applications

S	050	060	080	100	125	140	150
2000 < n1 < 3000	✓	✓	✓	✓	✓	B	B
V6	B	B	B	B	B	B	B
n1 > 3000	B	B	B	B	B	A	A
...L : V5 - V6	B	B	B	B	B	B	B
(*) ...L	B	B	B	B	B	B	B

✓ Verified application

A Application not recommended

B Check the application and/or call MOTOVARIO TECHNICAL SERVICE.

(*) The shrink disc is designed only to transmit the output torque.

In case of mounting position with radial and/or axial loads, please contact MOTOVARIO TECHNICAL SERVICE.

2.5.2 Information

The performance given in the catalogue correspond to mounting position B3 or similar, when the first stage is not entirely immersed in oil. For other mounting positions and/or particular input speeds, refer to the tables that highlight different critical situations for each size of gear reducer. It is also necessary to take due consideration of and carefully assess the following applications by calling MOTOVARIO TECHNICAL SERVICE:

- To avoid the use as multiplier.
- Use in services that could be hazardous for people if the gear reducer fails.
- Applications with especially high inertia.
- Use as a lifting winch.
- Applications with high dynamic strain on the case of the gear reducer.
- In places with T_{amb} under -5°C or over 40°C .
- Use in chemically aggressive environments.
- Use in a salty environment.
- Mounting positions not envisaged in the catalogue.
- Use in radioactive environments.
- Use in environments pressures other than atmospheric pressure.

Avoid applications where even partial immersion of the reducer is required.

In the presence of overloading due to full load, braking, shocks or other static and dynamic causes, please verify that the peak torque is less than $2 \cdot Mn_2$.

2.6 MOTOR FLANGE AVAILABILITY

B11 = Compact electric motor versions.

These tables report all possible dimensions. Please verify service factor.

*For motor size 063 the PS version does not exist.

#Ratio not existent for version IS.

CS - S - PS 052				
i	071	080	090	100-112
8,63	B5-B11	B5-B11	B5-B11	B5-B11
11,14	B5-B11	B5-B11	B5-B11	B5-B11
12,00	B5-B11	B5-B11	B5-B11	B5-B11
13,66	B5-B11	B5-B11	B5-B11	B5-B11
15,27	B5-B11	B5-B11	B5-B11	B5-B11
16,29	B5-B11	B5-B11	B5-B11	B5-B11
18,63	B5-B11	B5-B11	B5-B11	B5-B11
19,73	B5-B11	B5-B11	B5-B11	B5-B11
21,04	B5-B11	B5-B11	B5-B11	B5-B11
21,53	B5-B11	B5-B11	B5-B11	B5-B11
24,07	B5-B11	B5-B11	B5-B11	B5-B11
25,20	B5-B11	B5-B11	B5-B11	B5-B11
25,79	B5-B11	B5-B11	B5-B11	B5-B11
27,81	B5-B11	B5-B11	B5-B11	B5-B11
30,00	B5-B11	B5-B11	B5-B11	
32,55	B5-B11	B5-B11	B5-B11	B5-B11
33,00	B5-B11	B5-B11	B5-B11	
34,09	B5-B11	B5-B11	B5-B11	B5-B11
36,55	B5-B11	B5-B11	B5-B11	
38,75	B5-B11	B5-B11	B5-B11	
39,90	B5-B11	B5-B11	B5-B11	B5-B11
42,63	B5-B11	B5-B11	B5-B11	
46,00	B5-B11	B5-B11	B5-B11	
47,20	B5-B11	B5-B11	B5-B11	
52,25	B5-B11	B5-B11	B5-B11	
57,86	B5-B11	B5-B11	B5-B11	
59,42	B5-B11	B5-B11	B5-B11	
72,83	B5-B11	B5-B11	B5-B11	

CS - S - PS 053				
i	*063	071	080	090
36,50	B5-B11	B5-B11	B5-B11	B5-B11
47,14	B5-B11	B5-B11	B5-B11	B5-B11
57,79	B5-B11	B5-B11	B5-B11	B5-B11
63,74	B5-B11	B5-B11	B5-B11	B5-B11
78,14	B5-B11	B5-B11	B5-B11	B5-B11
74,20	B5-B11	B5-B11	B5-B11	B5-B11
95,84	B5-B11	B5-B11	B5-B11	B5-B11
117,48	B5-B11	B5-B11	B5-B11	B5-B11
137,45	B5-B11	B5-B11	B5-B11	B5-B11
177,55	B5-B11	B5-B11	B5-B11	B5-B11
198,45	B5-B11	B5-B11	B5-B11	
217,64	B5-B11	B5-B11	B5-B11	B5-B11
256,33	B5-B11	B5-B11	B5-B11	
314,21	B5-B11	B5-B11	B5-B11	

2.6 MOTOR FLANGE AVAILABILITY

CS - S - PS 062				
i	071	080	090	100-112
8,00		B5-B11	B5-B11	B5-B11
8,92		B5-B11	B5-B11	B5-B11
9,55		B5-B11	B5-B11	B5-B11
10,65		B5-B11	B5-B11	B5-B11
11,71		B5-B11	B5-B11	B5-B11
13,06		B5-B11	B5-B11	B5-B11
13,36		B5-B11	B5-B11	B5-B11
15,94		B5-B11	B5-B11	B5-B11
16,16		B5-B11	B5-B11	B5-B11
19,29		B5-B11	B5-B11	B5-B11
19,55		B5-B11	B5-B11	B5-B11
23,18	B5-B11	B5-B11	B5-B11	B5-B11
23,75	B5-B11	B5-B11	B5-B11	B5-B11
25,14	B5-B11	B5-B11	B5-B11	B5-B11
27,66	B5-B11	B5-B11	B5-B11	B5-B11
30,00	B5-B11	B5-B11	B5-B11	B5-B11
33,93	B5-B11	B5-B11	B5-B11	B5-B11
36,57	B5-B11	B5-B11	B5-B11	B5-B11
39,38	B5-B11	B5-B11	B5-B11	B5-B11
43,64	B5-B11	B5-B11	B5-B11	B5-B11
46,10	B5-B11	B5-B11	B5-B11	
48,30	B5-B11	B5-B11	B5-B11	B5-B11
53,53	B5-B11	B5-B11	B5-B11	B5-B11
55,00	B5-B11	B5-B11	B5-B11	
67,47	B5-B11	B5-B11	B5-B11	

CS - S - PS 063			
i	071	080	090
33,57	B5-B11	B5-B11	B5-B11
37,77	B5-B11	B5-B11	B5-B11
40,05	B5-B11	B5-B11	B5-B11
49,13	B5-B11	B5-B11	B5-B11
55,29	B5-B11	B5-B11	B5-B11
58,72	B5-B11	B5-B11	B5-B11
65,85	B5-B11	B5-B11	B5-B11
68,25	B5-B11	B5-B11	B5-B11
73,63	B5-B11	B5-B11	B5-B11
81,43	B5-B11	B5-B11	B5-B11
99,89	B5-B11	B5-B11	B5-B11
126,43	B5-B11	B5-B11	B5-B11
150,85	B5-B11	B5-B11	B5-B11
182,53	B5-B11	B5-B11	B5-B11
185,05	B5-B11	B5-B11	B5-B11
217,79	B5-B11		
267,16	B5-B11		

CS - S - PS 082				
i	080	090	100-112	132
7,34	B5-B11	B5-B11	B5-B11	B5-B11
8,06	B5-B11	B5-B11	B5-B11	B5-B11
9,94	B5-B11	B5-B11	B5-B11	B5-B11
11,61	B5-B11	B5-B11	B5-B11	B5-B11
12,75	B5-B11	B5-B11	B5-B11	B5-B11
14,04	B5-B11	B5-B11	B5-B11	B5-B11
15,43	B5-B11	B5-B11	B5-B11	B5-B11
15,73	B5-B11	B5-B11	B5-B11	B5-B11
17,29	B5-B11	B5-B11	B5-B11	B5-B11
19,03	B5-B11	B5-B11	B5-B11	B5-B11
20,14	B5-B11	B5-B11	B5-B11	B5-B11
22,13	B5-B11	B5-B11	B5-B11	B5-B11
24,00	B5-B11	B5-B11	B5-B11	B5-B11
26,05	B5-B11	B5-B11	B5-B11	B5-B11
27,29	B5-B11	B5-B11	B5-B11	B5-B11
28,67	B5-B11	B5-B11	B5-B11	B5-B11
29,60	B5-B11	B5-B11	B5-B11	B5-B11
31,78	B5-B11	B5-B11	B5-B11	B5-B11
34,91	B5-B11	B5-B11	B5-B11	B5-B11
35,50	B5-B11	B5-B11	B5-B11	
40,05	B5-B11	B5-B11	B5-B11	B5-B11
43,05	B5-B11	B5-B11	B5-B11	B5-B11
50,25	B5-B11	B5-B11	B5-B11	
54,27	B5-B11	B5-B11	B5-B11	
61,98	B5-B11	B5-B11	B5-B11	

CS - S - PS 083				
i	071	080	090	100-112
67,52		B5-B11	B5-B11	B5-B11
74,18		B5-B11	B5-B11	B5-B11
81,71		B5-B11	B5-B11	B5-B11
91,49		B5-B11	B5-B11	B5-B11
100,62		B5-B11	B5-B11	B5-B11
117,17	B5-B11	B5-B11	B5-B11	
128,73	B5-B11	B5-B11	B5-B11	
136,34	B5-B11	B5-B11	B5-B11	B5-B11
158,76	B5-B11	B5-B11	B5-B11	
184,88	B5-B11	B5-B11	B5-B11	
203,11	B5-B11	B5-B11	B5-B11	
205,34	B5-B11	B5-B11	B5-B11	B5-B11
226,04	B5-B11	B5-B11	B5-B11	B5-B11
250,50	B5-B11	B5-B11	B5-B11	
266,13	B5-B11	B5-B11	B5-B11	
292,36	B5-B11	B5-B11	B5-B11	
315,73	B5-B11	B5-B11	B5-B11	
360,58	B5-B11	B5-B11	B5-B11	

2.6 MOTOR FLANGE AVAILABILITY

CS - S - PS 102					
i	080	090	100-112	132	160
8,06	B5-B11	B5-B11	B5-B11	B5-B11	B5
8,85	B5-B11	B5-B11	B5-B11	B5-B11	B5
10,88	B5-B11	B5-B11	B5-B11	B5-B11	B5
12,75	B5-B11	B5-B11	B5-B11	B5-B11	B5
13,99	B5-B11	B5-B11	B5-B11	B5-B11	B5
15,43	B5-B11	B5-B11	B5-B11	B5-B11	
17,21	B5-B11	B5-B11	B5-B11	B5-B11	B5
19,00	B5-B11	B5-B11	B5-B11	B5-B11	
20,83	B5-B11	B5-B11	B5-B11	B5-B11	
22,13	B5-B11	B5-B11	B5-B11	B5-B11	
24,28	B5-B11	B5-B11	B5-B11	B5-B11	
26,33	B5-B11	B5-B11	B5-B11	B5-B11	
29,87	B5-B11	B5-B11	B5-B11	B5-B11	
32,40	B5-B11	B5-B11	B5-B11	B5-B11	
34,91	B5-B11	B5-B11	B5-B11	B5-B11	
38,30	B5-B11	B5-B11	B5-B11	B5-B11	
42,53	B5-B11	B5-B11	B5-B11	B5-B11	
44,00	B5-B11	B5-B11	B5-B11		
47,13	B5-B11	B5-B11	B5-B11	B5-B11	
50,25	B5-B11	B5-B11	B5-B11		
55,14	B5-B11	B5-B11	B5-B11		
59,40	B5-B11	B5-B11	B5-B11		
67,84	B5-B11	B5-B11	B5-B11		

CS - S - PS 103				
i	071	080	090	100-112
74,18		B5-B11	B5-B11	B5-B11
81,39		B5-B11	B5-B11	B5-B11
89,77		B5-B11	B5-B11	B5-B11
100,15		B5-B11	B5-B11	B5-B11
110,55	B5-B11	B5-B11	B5-B11	B5-B11
121,29	B5-B11	B5-B11	B5-B11	B5-B11
128,73	B5-B11	B5-B11	B5-B11	B5-B11
141,24	B5-B11	B5-B11	B5-B11	B5-B11
173,78	B5-B11	B5-B11	B5-B11	B5-B11
188,51	B5-B11	B5-B11	B5-B11	B5-B11
203,11	B5-B11	B5-B11	B5-B11	B5-B11
222,85	B5-B11	B5-B11	B5-B11	B5-B11
224,76	B5-B11	B5-B11	B5-B11	B5-B11
274,20	B5-B11	B5-B11	B5-B11	B5-B11
280,89	B5-B11	B5-B11	B5-B11	
292,36	B5-B11	B5-B11	B5-B11	
320,79	B5-B11	B5-B11	B5-B11	
345,60	B5-B11	B5-B11	B5-B11	
394,69	B5-B11	B5-B11	B5-B11	

CS - S - PS 122							
i	080	090	100-112	132	160	180	200
8,48					B5	B5	B5
9,30					B5	B5	B5
10,24					B5	B5	B5
11,42					B5	B5	B5
12,63					B5	B5	B5
13,84					B5	B5	B5
16,99					B5	B5	B5
21,25			B5-B11	B5-B11	B5	B5	
22,37			B5-B11	B5-B11	B5	B5	
23,29			B5-B11	B5-B11	B5	B5	
26,15			B5-B11	B5-B11	B5	B5	
28,60			B5-B11	B5-B11	B5	B5	
30,51			B5-B11	B5-B11	B5	B5	
32,76			B5-B11	B5-B11	B5	B5	
33,44			B5-B11	B5-B11	B5	B5	
35,20			B5-B11	B5-B11	B5	B5	
41,07			B5-B11	B5-B11	B5	B5	
43,60	B5-B11	B5-B11	B5-B11	B5-B11			
44,63	B5-B11	B5-B11	B5-B11	B5-B11			
49,04	B5-B11	B5-B11	B5-B11	B5-B11			
53,75	B5-B11	B5-B11	B5-B11	B5-B11			
66,00	B5-B11	B5-B11	B5-B11	B5-B11			

CS - S - PS 123				
i	080	090	100-112	132
64,84			B5-B11	B5-B11
71,07			B5-B11	B5-B11
78,46			B5-B11	B5-B11
87,27			B5-B11	B5-B11
105,91			B5-B11	B5-B11
112,52	B5-B11	B5-B11	B5-B11	B5-B11
123,33	B5-B11	B5-B11	B5-B11	B5-B11
130,04	B5-B11	B5-B11	B5-B11	B5-B11
133,78	B5-B11	B5-B11	B5-B11	B5-B11
151,43	B5-B11	B5-B11	B5-B11	B5-B11
177,53	B5-B11	B5-B11	B5-B11	B5-B11
194,59	B5-B11	B5-B11	B5-B11	B5-B11
215,60	B5-B11	B5-B11	B5-B11	B5-B11
238,93	B5-B11	B5-B11	B5-B11	B5-B11
# 255,54	B5-B11	B5-B11	B5-B11	
# 280,10	B5-B11	B5-B11	B5-B11	
# 301,16	B5-B11	B5-B11	B5-B11	
# 343,93	B5-B11	B5-B11	B5-B11	

2.6 MOTOR FLANGE AVAILABILITY

S142				
i	132	160	180	200
4.11	B5	B5	B5	B5
4.58	B5	B5	B5	B5
5.14	B5	B5	B5	B5
5.81	B5	B5	B5	B5
6.21	B5	B5	B5	B5
7.31	B5	B5	B5	B5
8.20	B5	B5	B5	B5
9.28	B5	B5	B5	B5
9.91	B5	B5	B5	B5
11.40	B5	B5	B5	B5
12.81	B5	B5	B5	B5
14.27	B5	B5	B5	B5
16.00	B5	B5	B5	B5
18.10	B5	B5	B5	B5
19.33	B5	B5	B5	B5
22.24	B5	B5	B5	B5
25.26	B5	B5	B5	
28.33	B5	B5	B5	
32.05	B5	B5	B5	
34.22	B5	B5	B5	
39.37	B5	B5		

S143			
i	100 - 112	132	160
45.76	B5	B5	B5
50.97	B5	B5	B5
57.17	B5	B5	B5
64.67	B5	B5	B5
69.05	B5	B5	B5
79.45	B5	B5	B5
98.80	B5	B5	
110.05	B5	B5	
123.43	B5	B5	
139.64	B5	B5	
149.09	B5	B5	
157.48	B5		
171.54	B5	B5	
175.40	B5		
196.73	B5		
222.56	B5		
237.62	B5		
273.41	B5		

S152				
i	160	180	200	225
4.06	B5	B5	B5	B5
4.53	B5	B5	B5	B5
5.20	B5	B5	B5	B5
5.71	B5	B5	B5	B5
6.52	B5	B5	B5	B5
7.28	B5	B5	B5	B5
8.35	B5	B5	B5	B5
9.17	B5	B5	B5	B5
10.41	B5	B5	B5	B5
12.46	B5	B5	B5	B5
13.90	B5	B5	B5	B5
15.96	B5	B5	B5	B5
17.52	B5	B5	B5	B5
19.90	B5	B5	B5	B5
22.88	B5	B5	B5	B5
27.10	B5	B5	B5	B5
29.75	B5	B5	B5	B5
33.79	B5	B5	B5	B5
38.84	B5	B5	B5	B5

S153			
i	132	160	180
40.10	B5	B5	B5
44.75	B5	B5	B5
51.37	B5	B5	B5
56.39	B5	B5	B5
64.05	B5	B5	B5
73.62	B5	B5	B5
87.16	B5	B5	
97.27	B5	B5	
111.66	B5	B5	
122.56	B5	B5	
139.20	B5	B5	
154.01	B5		
160.01	B5		
176.81	B5		
194.05	B5		
220.41	B5		
253.35	B5		

2.7 OUTPUT SHAFT BEARINGS

S	S050		S060		S080		S100	
Versions	Standard	On request	Standard	On request	Standard	On request	Standard	On request
C	1	/	1	2	1 (Ø40)	2 (Ø40)	1	2
D	1	/	1	/	2	/	2	/
L	1	/	1	/	1	/	1	/

S	S125		S140		S150	
Versions	Standard	On request	Standard	On request	Standard	On request
C	1	2	1	2	1	2
D	2	/	2	/	2	/
L	1	/	1	/	1	/

1 - Ball Bearing

2 - Roller bearings

/ - Not available

2.8.1 Information

The value of the admissible radial load [N] is given in the tables relating to the performance of the gear reducer at issue. It is related to the load applied on the centre line of the shaft and in the most unfavourable conditions of angle of application and direction of rotation. The maximum admissible axial loads are 1/5 of the value of the given radial load when they are applied in combination with the radial load. The tables relating to the output shafts give the maximum admissible value. This value must never be exceeded since it relates to the strength of the case. Particular conditions of radial load higher than the limits of the catalogue may occur. In this case, call our Technical Service and provide details on the application: direction of the load, direction of rotation of the shaft, type of service. In case of double extension shafts with radial load applied on both ends, the max. admissible radial loads must be defined according to the specific running conditions, in this case call our Technical Service. The radial load on the shaft is calculated with the following formula:

$$Fr_e = (2000 \cdot M \cdot fz) / D \leq Fr_1 \text{ or } Fr_2$$

- **Fr_e** [N] Resulting radial load
- **M** [Nm] Torque on the shaft
- **D** [mm] Diameter of the transmission member mounted on the shaft
- **Fr₁-Fr₂** [N] Value of the maximum admitted radial load (see relative tables)
- **fz** = 1,1 gear pinion - 1,4 chain wheel - 1,7 v-pulley - 2,5 flat pulley

2.8.2 Input

When the radial load is not on the centre line of the shaft, it is necessary to adjust the admissible radial load Fr₁ with the following formula: $Fr_x = (Fr_1 \cdot a) / (b + x)$

- **a**, **b** = values given in the tables
- **x** = distance from the point of application of the load to the shaft shoulder

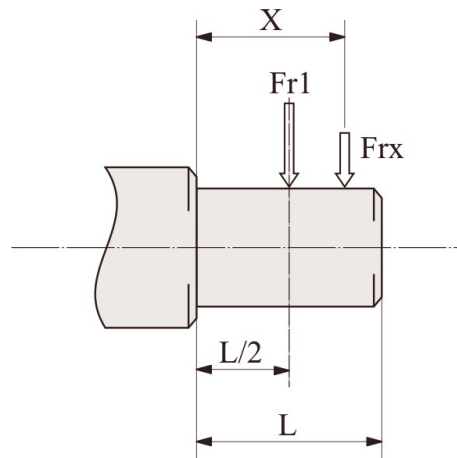

IS	052/053	062/063	082/083	102/103	122/123	142/143	152/153
a	105	105	137	137	175	146	190
b	80	80	108	108	135	106	135
Fr₁ max(**)	1500	2500	3600	3600	7200	4200	5200

(**Fr₁ max) Max admissible value of the reducer in static conditions and/or for limited operations. For continuous overhung loads please check the values on the performances tables calculated according to the casing, the shaft and bearings.

2.8.3 Output

When the radial load is not on the centre line of the shaft, it is necessary to adjust the admissible radial load Fr_2 with the following formula: $Fr_x = (Fr_2 \cdot a) / (b + x)$

- a , b = values given in the tables
- x = distance from the point of application of the load to the shaft shoulder

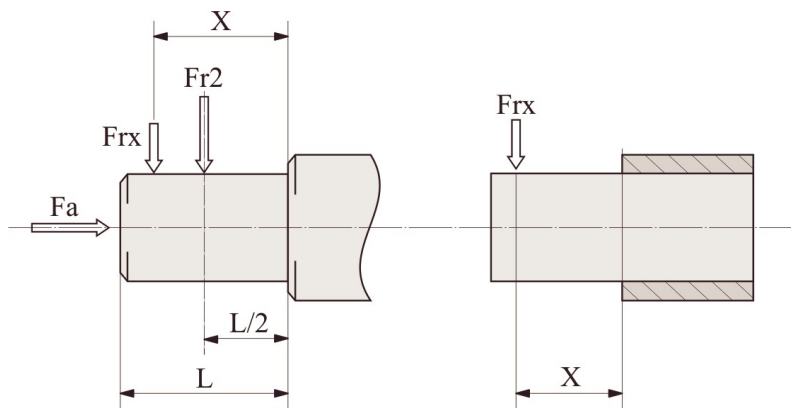

S	052/053	062/063	082/083	102/103	122/123	142/143	152/153
a	125	145	190	225	265	360,5	409,5
b	96	116	150	175	202	261	299
D (Fr_2 max ^{**})	6000	10000	18000	22000	30000	35000	40000
C (Fr_2 max ^{**})	6000	4000	7200	9000	11200	18500	19400

(** Fr_2 max) Max admissible value of the reducer in static conditions and/or for limited operations. For continuous overhung loads please check the values on the performances tables calculated according to the casing, the shaft and bearings.

2.9.1 Information

In cases of ambient temperatures not envisaged in the table, call our Technical Service. In the case of temperatures under -30°C or over 60°C it is necessary to use oil seals with special properties. For operating ranges with temperatures under 0°C it is necessary to consider the following:

1. The motors need to be suitable for operation at the envisaged ambient temperature.
2. The power of the electric motor needs to be adequate for exceeding the higher starting torques required.
3. In case of cast-iron gear reducers, pay attention to impact loads since cast iron may have problems of fragility at temperatures under -15°C.
4. During the early stages of service, problems of lubrication may arise due to the high level of viscosity taken on by the oil and so it is wise to have a few minutes of rotation under no load.

Oil (NON Atex products) must be changed after approx. 10000 hours/2 years of operation; this time varies based on the type of service and on the environment inside which the gear reducer is installed. Units not featuring any oil plug are life-lubricated, and therefore maintenance-free.

2.9.2 Lubricants

Specifications of lubricants recommended by Motovario.

The units **S052/3 ÷ 102/3** are supplied with ENI BLASIA 220 oil, unless otherwise specified by the client.

The units **S122/3 ÷ 152/3** are supplied without lubricant.

	S052/3 ÷ 152/3	
	Mineral oil	
T _{amb} °C ISO	(-5) ÷ (+40) ISO VG220	(-15) ÷ (+25) ISO VG150
ENI	BLASIA 220	BLASIA 150
SHELL	OMALA S2 G 220	OMALA S2 G 150
KLUBER	Kluberoil GEM 1-220N	Kluberoil GEM 1-150N
MOBIL	MOBILGEAR 600 XP220	MOBILGEAR 600 XP150
CASTROL	ALPHA SP 220	ALPHA SP 150
BP	ENERGOL GR-XP220	ENERGOL GR-XP150
PETRONAS	GEAR MEP 220	GEAR MEP 150

2.9.3 Special lubricants

	$T_{amb}^{\circ C}$	Polyglycol synthetic oil
ENI	$(-30) \div (+30)$	Blasia S 150 (ISO VG150)
	$(-20) \div (+40)$	Blasia S 220 (ISO VG220)
MOBIL	$(-45) \div (+0)$	SHC 624 (ISO VG32)
	$(-40) \div (+5)$	SHC 626 (ISO VG68)
KLUBER	$(-40) \div (+5)$	Klubersynth GH 6-32 (ISO VG32)
	$(-35) \div 10)$	Klubersynth GH 6-80 (ISO VG80)
	$(-30) \div (+40)$	Klubersynth GH 6-150 (ISO VG150)
	$(-25) \div (+40)$	Klubersynth GH 6-220 (ISO VG220)
	$(-15) \div (+50)$	Klubersynth GH 6-460 (ISO VG460)
	$(-10) \div (+70)$	Klubersynth GH 6-680 (ISO VG680)
	$T_{amb}^{\circ C}$	Polyglycol synthetic oil for food grade
KLUBER	$(-30) \div (+15)$	Klubersynth UH1-6 100 (ISO VG100)
	$(-25) \div (+40)$	Klubersynth UH1-6 220 (ISO VG220)
	$(-15) \div (+40)$	Klubersynth UH1-6 320 (ISO VG320)
	$(-15) \div (+50)$	Klubersynth UH1-6 460 (ISO VG460)
	$(-10) \div (+50)$	Klubersynth UH1-6 680 (ISO VG680)

If 'special' lubricant is required please contact MOTOVARIO TECHNICAL SERVICE.

2.9.4 Quantity

- For the gear reducers S ... series with 2, 3 stages it is always necessary to specify the envisaged position.
- The gear S... series with 2, 3 stages sizes 050, 060 gear reducers are supplied complete with lubricant, have no oil plugs and need no maintenance.
- The gear S... series with 2, 3 stages sizes 080, 100 gear reducers are supplied complete with lubricant and are fitted with oil plugs to suit any mounting position included in the catalogue
- The gear S... series with 2, 3 stages sizes 125, 140, 150 have no lubricant and are fitted with oil plugs to suit any mounting position included in the catalogue. The oil filling can be done on request, in this case it is recommended, after installation, to replace the closed plug used for transportation with the supplied breather plug. When the reduction unit is supplied without lubricant, it is provided with a label to be filled.

Oil quantity in the table (litres -) are indicative; for a proper use you will have to refer to the level plug or the dipstick. Any level difference could depend on construction tolerances, but also by the placement of the unit or by the mounting surface at the customer's premises. It is appropriate to check and, if necessary, restores the level when the units are installed.

S - CS	052/053	062/063	082/083	102/103	122/123	142	143	152	153
B3	2,05	2,4	6	9	14,7	22	20	29,7	27
B8	1,8	2,3	4	6	11,8	20	20	31	31
B6	2,4	2,9	5,7	8	16	22 (25)	18 (24,5)	29,3 (42)	24 (40)
B7	2,1	2,6	4,5	6,8	11,3	17,5	14	22,5	18
V5	2,8	3,5	6,8	10,3	19	24,5	23,5	34,4	33
V6	2,4	2,9	6,4	9,9	18	20,8	20	33,3	32

(...) 142-143-152-153 quantity of oil [l] for gearbox with backstop device

The following values of J1 moment of inertia are only estimated, referred to the maximum calculated, and to the gearbox input side.

S-2/3	J ₁ [Kg*m ²]
052/053	0,0004
062/063	0,0006
082/083	0,0015
102/103	0,0034
122/123	0,0085
142/143	0,0384
152/153	0,0830

3.1.1 S 052...123

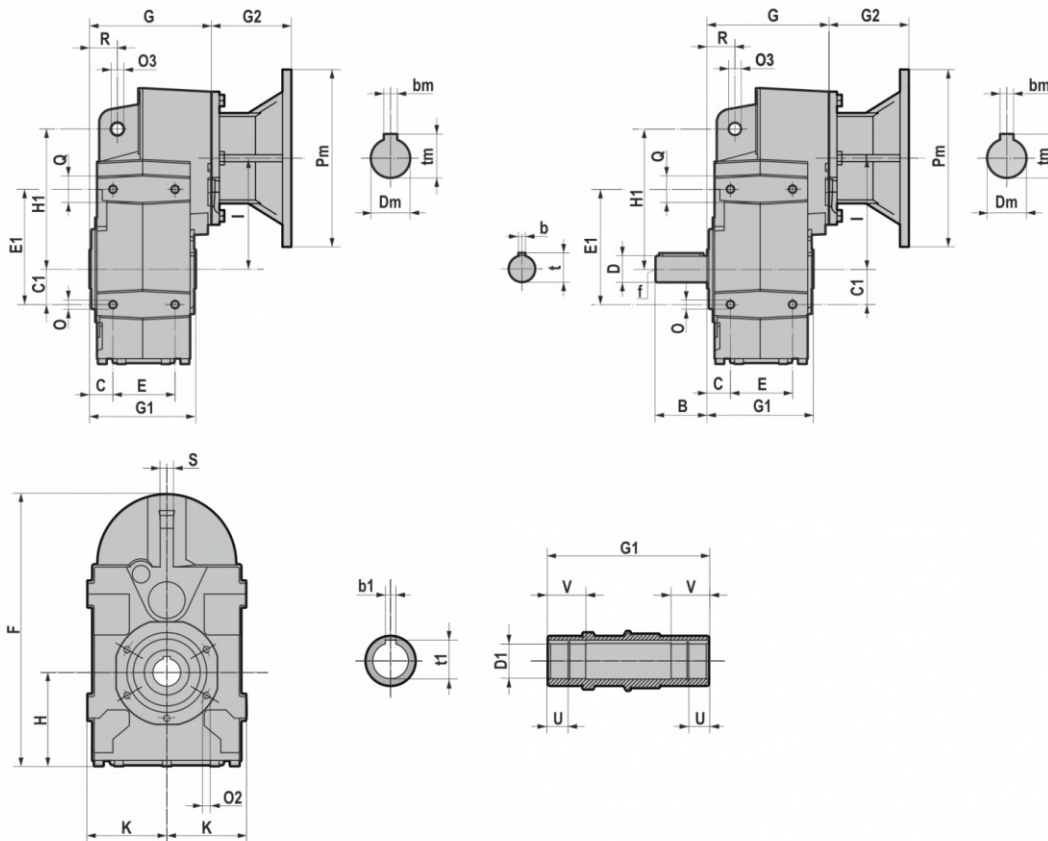

	D1 H7	b1	t1	U	V	B	D	b	t	f	C	C1	E	E1	F	G	G1	H	H1	I	K	O	O3	O2	Q	R	S
S052/S053	30	8	33	13,8	30	58	30 j6	8	33	M10	27	40	70	130	311	137,5	120	107	158	125	90,5	M10x18	14	M8x16 (n.5)	30	31,5	15
S062/S063	35	10	38	12	35	58	35 j6	10	38	M12	30	45	80	147	320	158,5	140	97	170	143	96,5	M12x20	14	M8x16 (n.5)	40	32	15
S082/S083	40	12	43	22,3	42	80	40 k6	12	43	M16	37	60	106	190	383	207	180	107	218	170	112,5	M12x20	14	M10x20 (n.7)	44	41	20
	45	14	47,6	22,3	42		50 k6	14	54	M16	37	70	137	275	426	217,5	210	119	278	180	130	M16x26	22	M12x22 (n.7)	50	50	20
S102/S103	45	14	49	22,3	50	100	50 k6	14	54	M16	37	70	137	275	426	217,5	210	119	278	180	130	M16x26	22	M12x22 (n.7)	50	50	20
	50	14	54	25	50		60 m6	18	64	M20	43	100	165	310	558	257	240	166	346	235	165	M16x30	22	M14x28 (n.7)	50	62	26
S122/S123	55	16	59,3	28	70	120	60 m6	18	64	M20	43	100	165	310	558	257	240	166	346	235	165	M16x30	22	M14x28 (n.7)	50	62	26
	60	18	64																								

IEC	Pm x Dm	G2				
		S052/S053	S062/S063	S082/S083	S102/S103	S122/S123
063	140x11	57	/	/	/	/
071	160x14	69	69	49	49	/
080	200x19	90	90	70	70	60,5
090	200x24	90	90	70	70	60,5
100-112	250x28	105	105	85	85	75,5
132	300x38	/	/	110	110	100,5
160	350x42	/	/	/	157,5	148
180	350x48	/	/	/	/	148
200	400x55	/	/	/	/	185

B5	Pm	Dm	bm	tm
063	140	11	4	12,8
071	160	14	5	16,3
080	200	19	6	21,8
090	200	24	8	27,3
100	250	28	8	31,3
112	250	28	8	31,3
132	300	38	10	41,3
160	350	42	12	45,3
180	350	48	14	51,8
200	400	55	16	59,3

3.1 REDUCERS/GEARED MOTORS

3.1.2 S 142...153

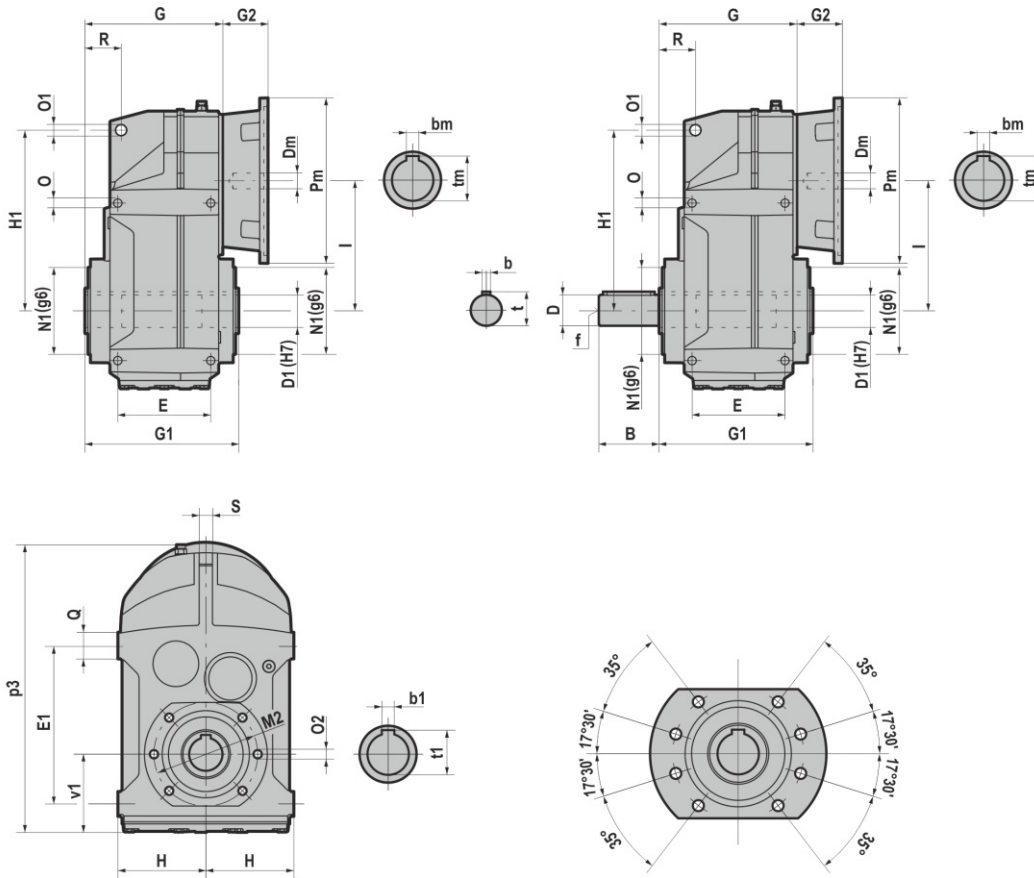

	D1	b1	t1	B	D	b	t	f	E	E1	G	G1	H	H1	I	N1	M2	O	O1	O2	p3	Q	R	S	v1
S142/S143	70	20	74,9	140	70	20	74,5	M20	205	350	282	300	200	395	269	180	220	M20x28	26	M16x26	615	50	70	30	177
	65	18	69,4																						
S152/S153	80	22	85,4	170	90	25	95	M20	220	400	321,5	350	225	485	325	210	260	M24x36	26	M20x30	730	60	88	36	213
	90	25	95,4																						

IEC	Pm x Dm	G2	
		S142/S143	S152/S153
100-112	250x28	73,5	/
132	300x38	84,0	87,5
160	350x42	119,5	112
180	350x48	119,5	112
200	400x55	119,5	113
225	450x60	/	144,5

B5	Pm	Dm	bm	tm
100	250	28	8	31,3
112	250	28	8	31,3
132	300	38	10	41,3
160	350	42	12	45,3
180	350	48	14	51,8
200	400	55	16	59,3
225	450	60	18	64,4

3.1.3 CS 052...123

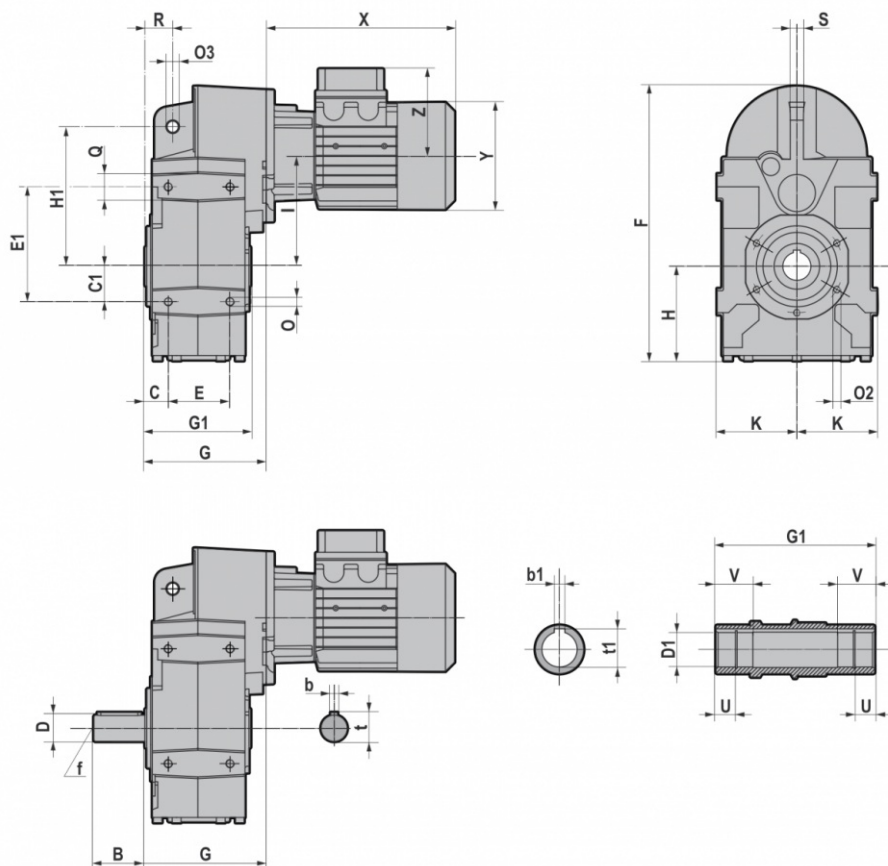

	D1 H7	b1	t1	U	V	B	D	b	t	f	C	C1	E	E1
CS052/CS053	30	8	33	13,8	30	58	30 j6	8	33	M10	27	40	70	130
CS062/CS063	35	10	38	12	35	58	35 j6	10	38	M12	30	45	80	147
CS082/CS083	40	12	43	22,3	42	80	40 k6	12	43	M16	37	60	106	190
	45	14	47,6	22,3	42									
CS102/CS103	45	14	49	22,3	50	100	50 k6	14	54	M16	37	70	137	275
	50	14	54	25	50									
CS122/CS123	55	16	59,3	28	70	120	60 m6	18	64	M20	43	100	165	310
	60	18	64											

	F	G	G1	H	H1	I	K	O	O3	O2	Q	R	S
CS052/CS053	311	137,5	120	107	158	125	90,5	M10x18	14	M8x16 (n.5)	30	31,5	15
CS062/CS063	320	158,5	140	97	170	143	96,5	M12x20	14	M8x16 (n.5)	40	32	15
CS082/CS083	383	207	180	107	218	170	112,5	M12x20	14	M10x20 (n.7)	44	41	20
CS102/CS103	426	217,5	210	119	278	180	130	M16x26	22	M12x22 (n.7)	50	50	20
CS122/CS123	558	257	240	166	346	235	165	M16x30	22	M14x28 (n.7)	50	62	26

3.1 REDUCERS/GEARED MOTORS

T (IE1 - IE2 - IE3)										
		063	071	080	090S	090L	100	112	132S	132M/L
CS052/CS053 CS062/CS063	X	215	241	268 *291	296 *329	321 *354	333	351 *375	/	/
	Y	121	139	158	173	173	191	211	/	/
	Z	104	112	122	130	130	139	154	/	/
CS082/CS083 CS102/CS103	X	/	221	248 *271	276 *309	301 *334	335	356 *380	405	443
	Y	/	139	158	173	173	191	211	249	249
	Z	/	112	122	130	130	139	154	194	194
CS122/CS123	X	/	/	/	267 *300	292 *325	326	347 *371	396	434
	Y	/	/	/	173	173	191	211	249	249
	Z	/	/	/	130	130	139	154	194	194

TB (IE1 - IE2 - IE3)										
		063	071	080	090S	090L	100	112	132S	132M/L
CS052/CS053 CS062/CS063	X	273	306,5	341 *364	373 *406	398 *431	415	448 *472	/	/
	Y	121	139	158	173	173	191	211	/	/
	Z	119	129	137	157	157	168	183	/	/
CS082/CS083 CS102/CS103	X	/	286,5	321 *344	353 *386	378 *411	417	453 *477	505	547
	Y	/	139	158	173	173	191	211	249	249
	Z	/	129	137	157	157	168	183	230	230
CS122/CS123	X	/	/	/	343 *376	368 *401	407	443 *467	495	537
	Y	/	/	/	173	173	191	211	249	249
	Z	/	/	/	157	157	168	183	230	230

*TP80B4, TP90S4, TP90L4, TP90S6, TP112M4, TP112M6

3.1.4 IS 052...123

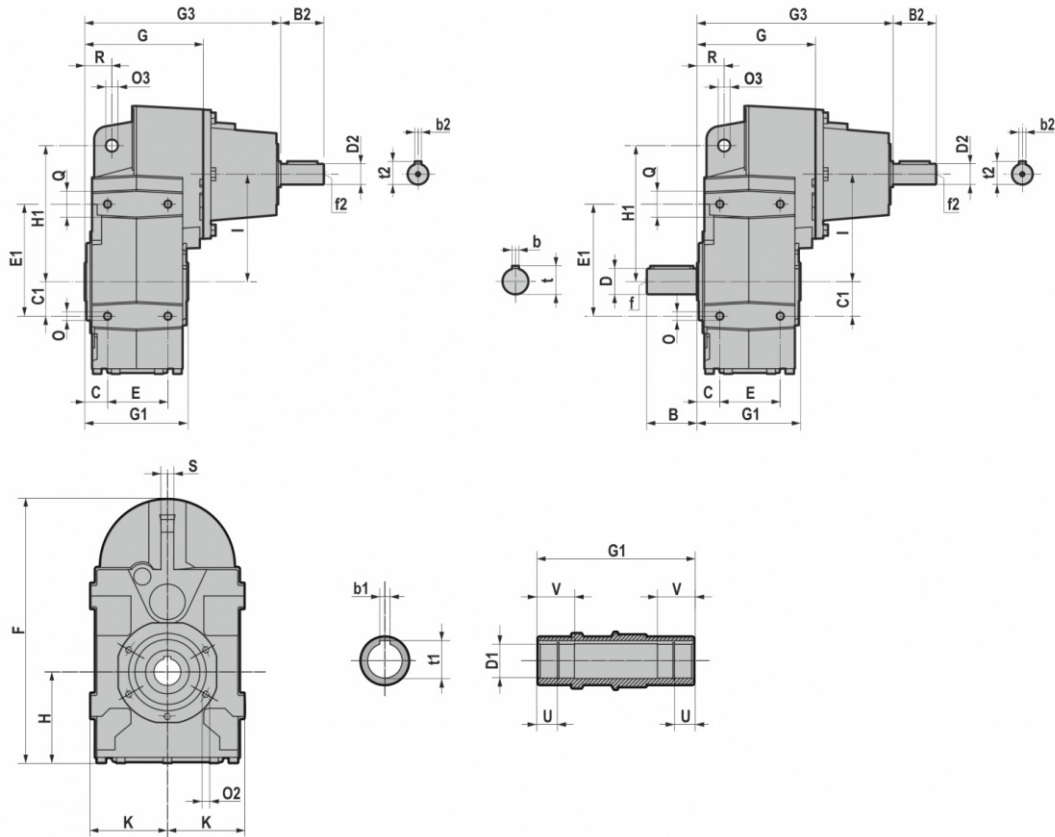

	D1 H7	b1	t1	U	V	B	D	b	t	f	C	C1	E	E1	F	G	G1	H	H1	I	K	O	O3	O2	Q	R	S
IS052/IS053	30	8	33	13,8	30	58	30 j6	8	33	M10	27	40	70	130	311	137,5	120	107	158	125	90,5	M10x18	14	M8x16 (n.5)	30	31,5	15
IS062/IS063	35	10	38	12	35	58	35 j6	10	38	M12	30	45	80	147	320	158,5	140	97	170	143	96,5	M12x20	14	M8x16 (n.5)	40	32	15
IS082/IS083	40	12	43	22,3	42	80	40 k6	12	43	M16	37	60	106	190	383	207	180	107	218	170	112,5	M12x20	14	M10x20 (n.7)	44	41	20
	45	14	47,6	22,3	42																						
IS102/IS103	45	14	49	22,3	50	100	50 k6	14	54	M16	37	70	137	275	426	217,5	210	119	278	180	130	M16x26	22	M12x22 (n.7)	50	50	20
	50	14	54	25	50																						
IS122/IS123	55	16	59,3	28	70	120	60 m6	18	64	M20	43	100	165	310	558	257	240	166	346	235	165	M16x30	22	M14x28 (n.7)	50	62	26
	60	18	64																								

	G3	B2	D2	b2	t2	f2
IS052/IS053	227,5	50	24 j6	8	27	M8
IS062/IS063	248,5	50	24 j6	8	27	M8
IS082/IS083	320	60	28 j6	8	31	M10
IS102/IS103	330,5	60	28 j6	8	31	M10
IS122/IS123	383,5	80	38 k6	10	41	M12

3.1.5 IS 142...153

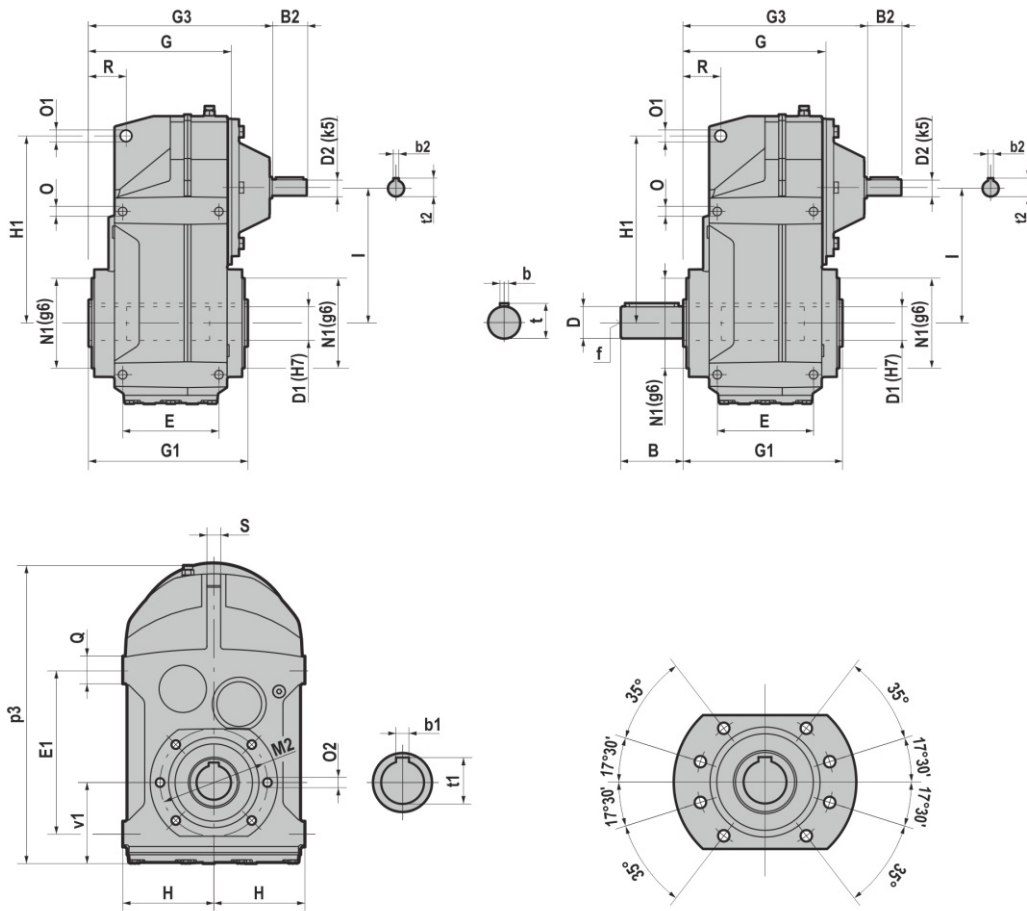

	D1	b1	t1	B	D	b	t	f	E	E1	G	G1	H	H1	I	N1	M2	O	O1	O2	p3	Q	R	S	v1
IS142/IS143	70	20	74,9	140	70	20	74,5	M20	205	350	282	300	200	395	269	180	220	M20x28	26	M16x26	615	50	70	30	177
	65	18	69,4																						
IS152/IS153	80	22	85,4	170	90	25	95	M20	220	400	321,5	350	225	485	325	210	260	M24x36	26	M20x30	730	60	88	36	213
	90	25	95,4																						

	G3	D2	B2	b2	t2
IS142/IS143	362	38	80	10	41
IS152/IS153	422	42	110	12	45

3.2 WEIGHTS

The values reported in the tables are referred to the weight of the gearbox with lubricant (S140/S150 supplied without lubricant) included.

*Weight without motor.

* S-PS	063	071	080-090	100-112	132	160	180	200	225	
052-053	16	16,4	17	21,2	/	/	/	/	/	- kg
062-063	/	19,9	20,6	24,9	/	/	/	/	/	
082-083	/	32,9	35	37	39,7	/	/	/	/	
102-103	/	44	46	48	50,7	57,4	57,4	/	/	
122-123	/	/	82	84,2	87	93	93	108	/	
142	/	/	/	/	172	180	180	183	/	
143	/	/	/	175	183	190	/	/	/	
152	/	/	/	/	/	255	255	258	264	
153	/	/	/	/	250	270	270	/	/	

IS	- kg
052-053	19,2
062-063	22,7
082-083	39
102-103	50
122-123	91,8
142	155
143	165
152	220
153	240

CS	TH			
	63	71	80	
052-053	20,18	21,476	26,8	- kg
062-063	/	24,976	30,4	
082-083	/	37,576	43,3	
102-103	/	48,576	54,3	

CS	TBH			
	63	71	80	
052-053	21,7	23,7	30,3	- kg
062-063	/	27,3	33,9	
082-083	/	39,8	46,7	
102-103	/	50,8	57,7	

CS	TP							
	80	090S	090L	100	112	132S	132M	
052-053	28,4	34,8	36,4	41,8	62,2	/	/	- kg
062-063	32	38,4	40	45,4	65,8	/	/	
082-083	44,9	49,8	50,9	55,9	76,2	95,3	99,6	
102-103	55,9	60,8	61,9	66,9	87,2	106,3	110,6	
122-123	/	96,8	97,4	103,3	122,2	142,3	144	

CS	TBP							
	80	090S	090L	100	112	132S	132M	
052-053	31,9	40,3	41,9	48,7	74,6	/	/	- kg
062-063	35,5	43,9	45,5	52,3	78,2	/	/	
082-083	48,3	55,3	56,4	62,7	88,6	109,3	113,6	
102-103	59,3	66,3	67,4	73,7	99,6	120,3	124,6	
122-123	/	102,3	102,9	107	134,6	156,3	158	

3.3 SHAFT END

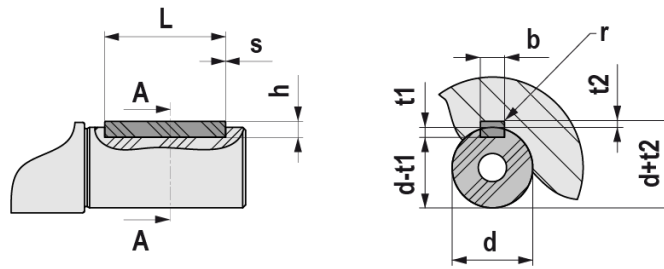

UNI 6604 - DIN 6885														
d		b x h		Tol. b/h	L		s min / max		b	t1	t2	Tol. t1/t2	r max	
	6	8	2	x	2	h9 / h9	6	20	0,16 0,25	2	1,2	1	0,1 0	0,08 0,16
>	8	10	3	x	3		6	36		3	1,8	1,4		
>	10	12	4	x	4		8	45		4	2,5	1,8		
>	12	17	5	x	5		10	56	5	3	2,3	0,25 0,4		0,16 0,25
>	17	22	6	x	6		14	70	6	3	2,8			
>	22	30	8	x	7		18	90	8	4	3,3			
>	30	38	10	x	8	22	110	10	5	3,3	0,2 0	0,25 0,4		
>	38	44	12	x	8	28	140	12	5	3,3				
>	44	50	14	x	9	36	160	14	5,5	3,8				
>	50	58	16	x	10	45	180	16	6	4,3		0,4 0,6		
>	58	65	18	x	11	50	200	18	7	4,4				
>	65	75	20	x	12	56	110	20	7,5	4,9				
>	75	85	22	x	14	h9 / h11	63	140	0,6 0,8	22	9	5,4	0,3 0	0,4 0,6
>	85	95	25	x	14		70	160		25	9	5,4		
>	95	110	28	x	16		80	180		28	10	6,4		
>	110	130	32	x	18		90	200	32	11	7,4	0,7 1		
>	130	150	36	x	20		100	160	36	12	8,4			
>	150	170	40	x	22		110	180	40	13	9,4			
>	170	200	45	x	25	125	200	45	14	10,4				

3.4.1 Electric motors

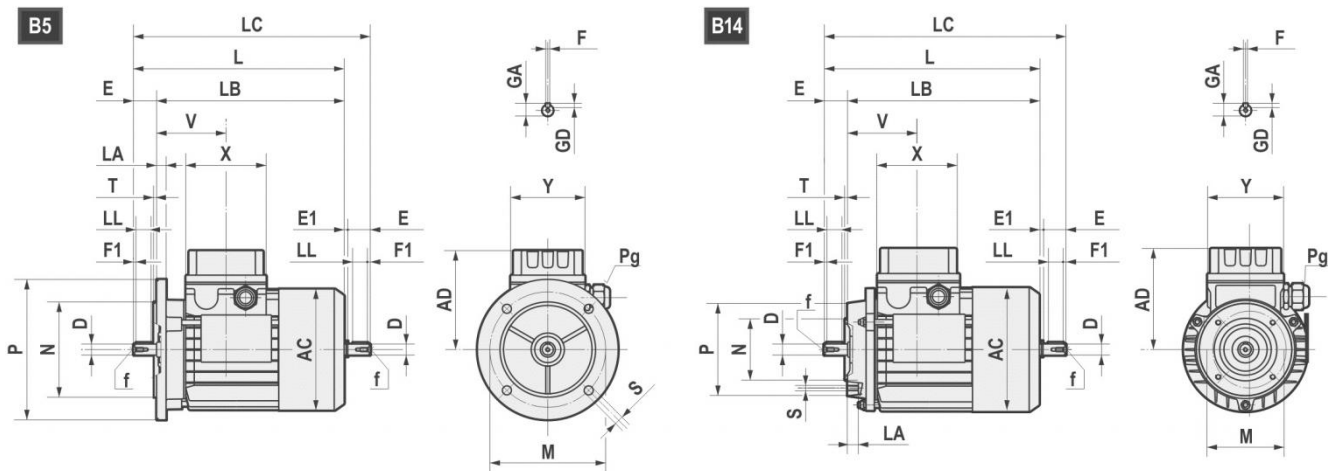

	AC	AD	L	LB	LC	X	Y	V	D	E	E1	f	F1	GA	F	GD
63	121	104	211	188	235,5	80	74	69	11 j6	23	1,5	M4x10	2,5	12,5	4	4
71	139	112	238,5	208,5	271	80	74	74,5	14 j6	30	2,5	M5x12,5	3	16	5	5
80	158	122	272,5 *296	232,5 *256	314 *337	80	74	78	19 j6	40	1,5	M6x16	5	21,5	6	6
90S	173	146	298 *331	248 *281	349,5 *381	98	98	89,5	24 j6	50	1,5	M8x19	5	27	8	7
90L	173	146	323 *356	273 *306	374,5 *408	98	98	89,5	24 j6	50	1,5	M8x19	5	27	8	7
100	191	155	368	308	431,5	98	98	97,5	28 j6	60	3,5	M10x22	7,5	31	8	7
112	211	170	382,5 *408	322,5 *348	447 *472	98	98	100	28 j6	60	3,5	M10x22	7,5	31	8	7
132S	249	195	452	372	536,5	118	118	115,5	38 k6	80	4	M12x28	10	41	10	8
132L	249	195	490	410	574,5	118	118	115,5	38 k6	80	4	M12x28	10	41	10	8
160S	249	195	520	410	/	118	118	115,5	42k6	100	/	M16x36	10	45	12	8

*TP80B4, TP90S4, TP90L4, TP90S6, TP112M4, TP112M6

B5	M	N	P	LA	S	T
63	115	95	140	10	9	3
71	130	110	160	10	9,5	3,5
80	165	130	200	12	11	3,5
90	165	130	200	12	11	3,5
100	215	180	250	15	14	4
112	215	180	250	14,5	14	4
132	265	230	300	20	14	3,5
160	300	250	350	13	18,5	3,5

B14	M	N	P	LA	S	T
63	75	60	90	10	M5	2,5
71	85	70	105	10,5	M6	2,5
80	100	80	120	10,5	M6	3
90	115	95	140	11,5	M8	3
100	130	110	160	15	M8	3,5
112	130	110	160	11,5	M8	3,5
132	165	130	200	20,5	M10	3,5
160	215	180	250	-	M12	4

3.4 ELECTRIC MOTORS

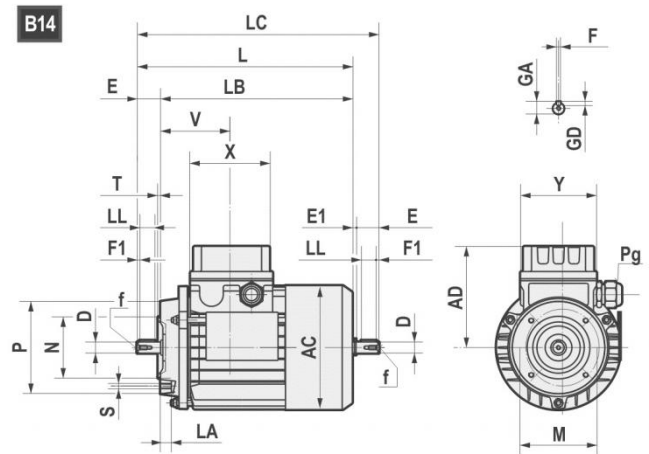
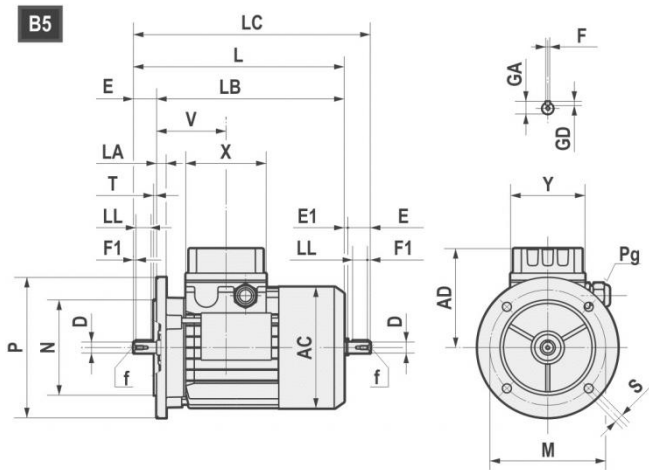

		AC	AD	L	LB	X	D	E	f	GA	F	GD	LL	Pg	
160M	2-4-6	314	251	600	490	158	42	110	M16	45	12	8	90	2-M40x1,5	1-M16x1,5
160L	2-4-6	314	251	645	535	158	42	110	M16	45	12	8	90	2-M40x1,5	1-M16x1,5
180M	2-4	355	267	680	570	158	48	110	M16	51,5	14	9	100	2-M40x1,5	1-M16x1,5
180L	4-6	355	267	720	610	158	48	110	M16	51,5	14	9	100	2-M40x1,5	1-M16x1,5
200L	2-4-6	397	300	785	675	187	55	110	M20	59	16	10	100	2-M50x1,5	1-M16x1,5
225S	4	446	325	820	680	187	60	140	M20	64	18	11	125	2-M50x1,5	1-M16x1,5
225M	2	446	325	815	705	187	55	110	M20	59	16	10	100	2-M50x1,5	1-M16x1,5
225M	4-6	446	325	845	705	187	60	140	M20	64	18	11	125	2-M50x1,5	1-M16x1,5
250M	2-4-6	485	360	910	770	238	60	140	M20	64	18	11	125	2-M63x1,5	1-M16x1,5
250M	2-4-6	485	360	910	770	238	65	140	M20	69	18	11	125	2-M63x1,5	1-M16x1,5
280S	2-4-6	547	390	970	830	238	65	140	M20	69	18	11	125	2-M63x1,5	1-M16x1,5
280S	2-4-6	547	390	970	830	238	75	140	M20	79,5	20	12	125	2-M63x1,5	1-M16x1,5
280M	2-4-6	547	390	1025	885	238	65	140	M20	69	18	11	125	2-M63x1,5	1-M16x1,5
280M	2-4-6	547	390	1025	885	238	75	140	M20	79,5	20	12	125	2-M63x1,5	1-M16x1,5

B5	M	N	P	LA	S	T
160	300	250	350	13	19	5
180	300	250	350	15	19	5
200	350	300	400	17	19	5
225	400	350	450	20	19	5
250	500	450	550	22	19	5
280	500	450	550	22	19	5

3.4.2 Standard high efficiency (TS), high (TH) and premium (TP) motors

Motovario, three-phase, single polarity motors are available in three different versions (IE1-IE2-IE3) in compliance with standard 60034-30-1. The efficiency value is calculated according to the method set forth in standard IEC 60034-2-1.

1. IE1: Standard efficiency TS series for rated power less than 0.12 kW;
2. IE2: High efficiency TH series for rated power greater than or equal to 0.12 kW and less than 0.75 kW;
3. IE3: Premium efficiency TP series (*) for nominal power greater than or equal to 0.75 kW.

Table of Motovario commercial availability

NOMINAL POWER [kW]	EFFICIENCY LEVEL		
	IE1	IE2	IE3
$P_n < 0,12$	TS-TBS	-	-
$0,12 \leq P_n < 0,75$	-	TH-TBH	-
$P_n \geq 0,75$	-	-	TP-TBP

(*) Motor TP100LA4 2,2 kW and all TP 6 poles motors are available at 60Hz only upon request. As a consequence, these motors are in IE3 efficiency level at 50 Hz and IE2 at 60 Hz in case of bifrequency electrical design (standard 230/400-265/460V 50-60Hz and optional 200/346-220/380V 50-60Hz, 290/500-330/575V 50-60Hz and 400/690-460/800V 50-60Hz, see chapter on input voltage and frequency, see motors catalog).

3.4.3 Nominal power - [kW]

P.	63A	63B	63C	71A	71B	71C	80A			80B		
	TS	TS	TS	TS	TS	TS	TS	TH	TP	TS	TH	TP
2	0,18	0,25	0,37	0,37	0,55	-	-	0,75	0,75	-	1,1	1,1
4	0,12	0,18	0,22	0,25	0,37	0,55	0,55	-	-	-	0,75	0,75
6	0,09	0,12	0,15	0,18	0,25	0,37	0,37	-	-	0,55	-	-

P.	90S		90L		100LR	100L	100LA		112MR	112MS	112MA	112M
	TH	TP	TH	TP	TP	TP	TH	TP	TP	TP	TH	TP
2	1,5	1,5	2,2	2,2	-	3	3	-	-	-	4	4
4	1,1	1,1	1,5	1,5	-	-	2,2	2,2	2,2	3	4	4
6	-	0,75	0,75	-	1,1	1,5	1,1	-	-	-	2,2	2,2

P.	112MR	112MS	132S	132SA	132MS	132SB	132M	132MA		132MB	
	TP	TP	TP	TH	TP	TH	TP	TH	TP	TH	TP
2	-	-	5,5	5,5	-	7,5	7,5	9,2	-	-	-
4	2,2	3	-	5,5	5,5	-	7,5	7,5	-	-	9,2
6	-	-	3	3	-	-	-	4	4	5,5	5,5

P.	160M	160MA	160MB	160L	160LA	180M	180L
	TP	TP	TP	TP	TP	TP	TP
2	-	11	15	18,5	-	22	-
4	-	11	-	-	15	18,5	22
6	7,5	-	-	11	-	-	15

P.	200L	200LA	200LB	225S	225M	250M	280S	280M
	TP	TP	TP	TP	TP	TP	TP	TP
2	-	30	37	-	-	-	-	-
4	30	-	-	37	45	55	75	90
6	-	18,5	22	-	-	-	-	-

4.1 LOW SPEED SHAFTS

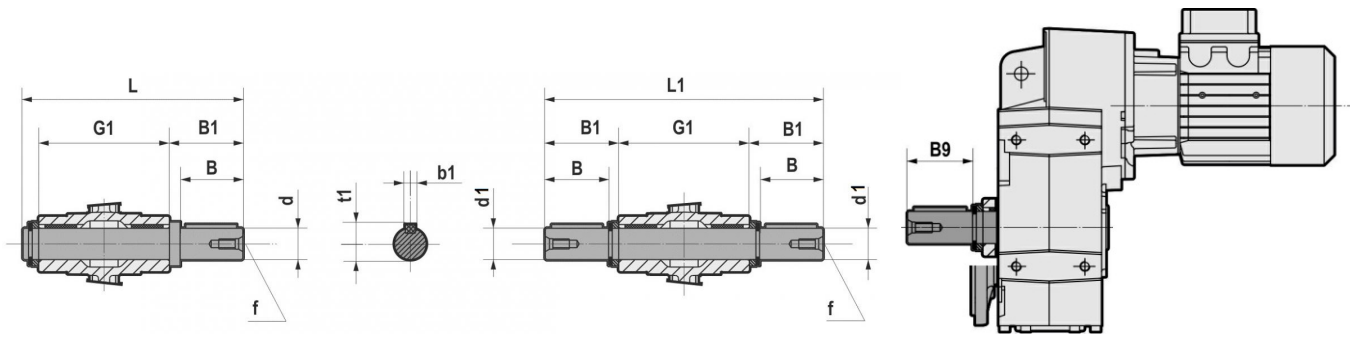

	d h6	B	B1	G1	L	f	b1	t1
S062/S063	35	58	62	140	210,5	M12	10	38
S082/S083	40	80	84,25	180	273	M16	12	43
S102/S103	50	100	105	210	325	M16	14	53,5
S122/S123	60	120	125	240	375	M20	18	64

	d k5	d1 h6	B	B1	B9	L1	f	b1	t1
S142/S143	70	70	140	150	140	600	M20	20	74,5
	65	65							69
S152/S153	90	90	170	180	170	710	M24	25	95
	80	80							M20

4.2 OUTPUT FLANGE

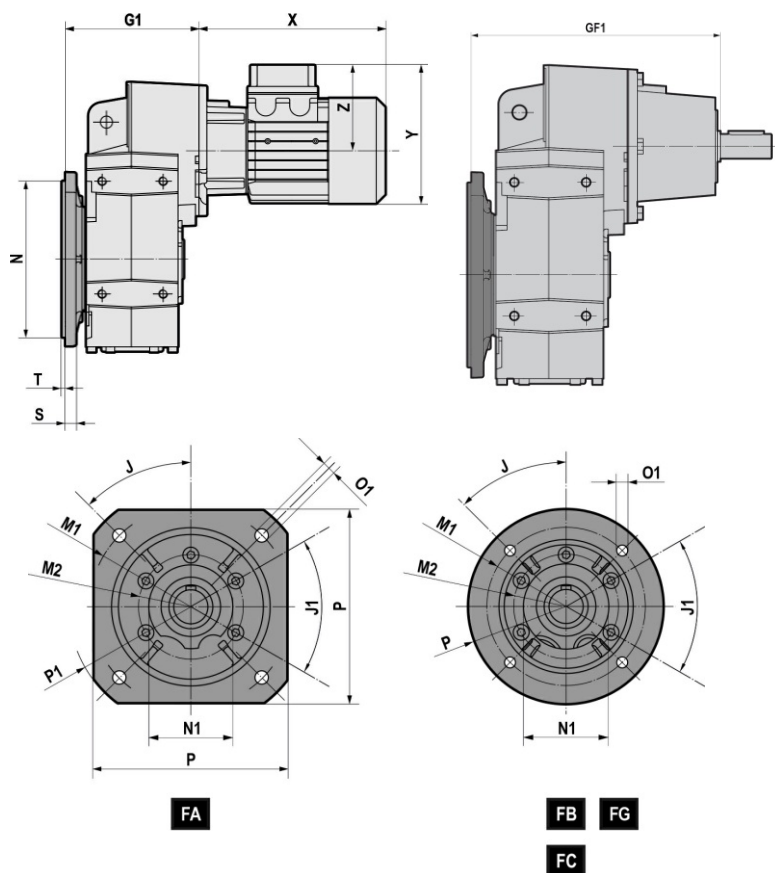

		J	J1	M1	M2	N f8	N1	O1	P	P1	S	T	G1	GF1
S052 S053	FA	45°	60°	215	105	180	90	14 (n.4)	200	250	12	4	153	243
	FB	45°	60°	165	105	130	90	11 (n.4)	200	/	12	3,5	153	243
S062 S063	FA	45°	60°	215	105	180	90	14 (n.4)	200	250	12	4	172,5	262,5
	FB	45°	60°	165	1050	130	90	11 (n.4)	200	/	12	3,5	172,5	262,5
S082 S083	FA	45°	45°	265	130	230	110	14 (n.4)	250	300	15	4	227	340
	FB	45°	45°	215	130	180	110	14 (n.4)	250	/	15	4	227	340
	FC	45°	45°	165	130	130	110	11 (n.4)	200	/	15	3,5	227	340
S102 S103	FA	45°	45°	300	165	250	130	18 (n.4)	300	350	16	5	247,5	360,5
	FB	45°	45°	265	165	230	130	14 (n.4)	300	/	16	4	247,5	360,5
	FC	45°	45°	215	165	180	130	14 (n.4)	250	/	16	4	247,5	360,5
S122 S123	FA	45°	45°	350	185	300	150	18 (n.4)	350	400	18	5	287	413,5
	FB	45°	45°	300	185	250	150	18 (n.4)	350	/	18	5	287	413,5
	FC	45°	45°	265	185	230	150	14 (n.4)	300	/	18	4	287	413,5
S142 S143	FG	22°30'	/	400	/	350 g6	/	18 (n.8)	450	/	20	5	338,5	426
S152 S153	FG	22°30'	/	400	/	350 g6	/	18 (n.8)	450	/	20	5	372,5	481

4.3.1 Reaction bolt

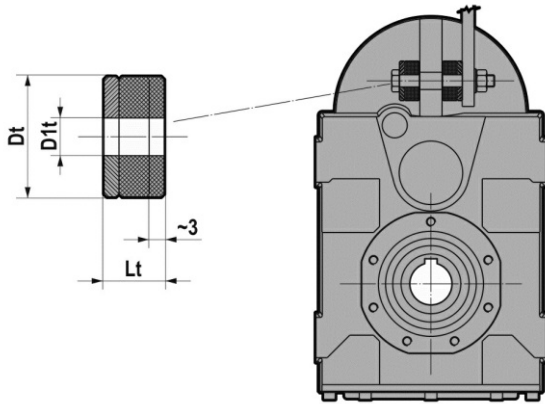

	Dt	D1t	Lt
S052/S053	40	12,5	20
S062/S063	40	12,5	20
S082/S083	40	12,5	20
S102/S103	60	21	30
S122/S123	60	21	30
S142/S143	60	25	38,8
S152/S153	60	25	35,5

4.3.2 Torque arm - S 142...153

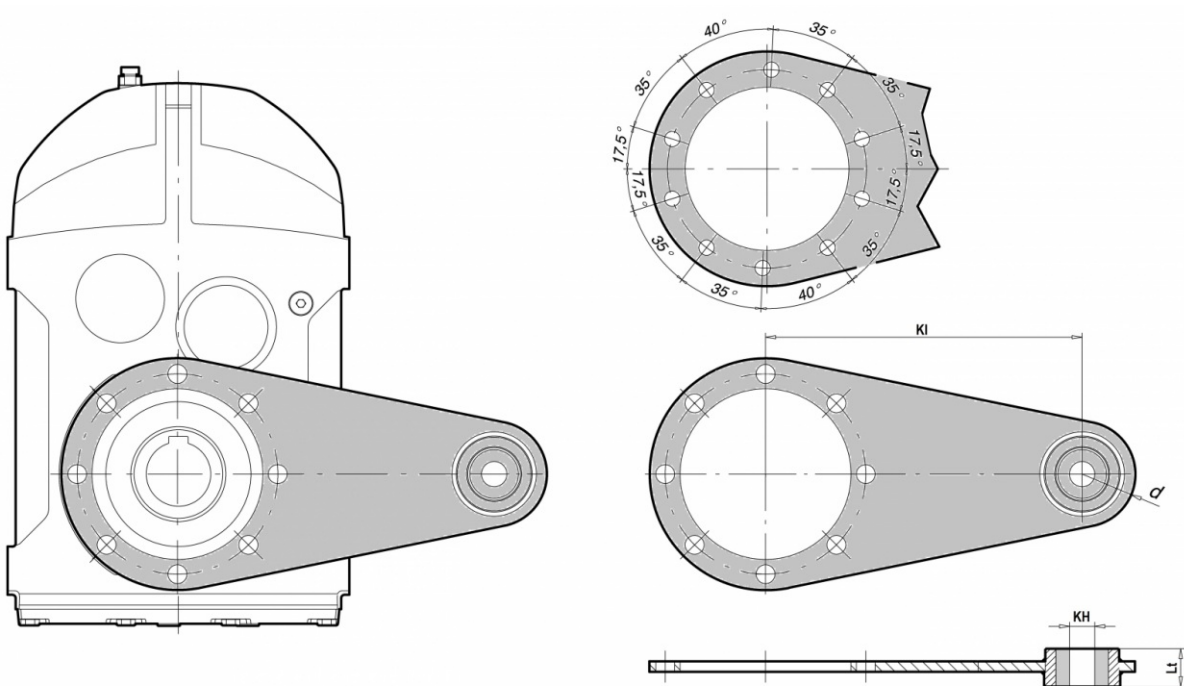

	KI	KH $\pm 0,2$	d	Lt
S142/S143	350	25	45	30
S152/S153	450	25	50	30

4.4 BACKSTOP DEVICE

The gear reducer can be supplied with backstop device on input shaft. Backstop device allows output shaft rotation in only one sense of direction; according to the size, it is available in the input flange or in the motor with the same dimensions. It is important to specify the required sense of direction on the order. The backstop device is not available for mounting position V5 with motor size IEC 100...225.

SENSE OF DIRECTION AVAILABLE

S... 2/C-D-L

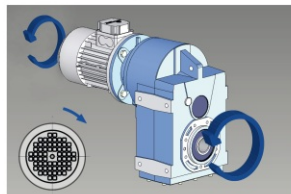

CLOCKWISE SENSE OF DIRECTION
REFERRED TO HIGH SPEED SHAFT

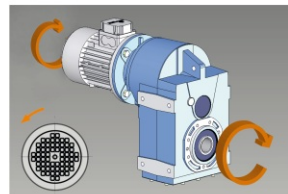

COUNTER CLOCKWISE SENSE OF DIRECTION
REFERRED TO HIGH SPEED SHAFT

S... 3/C-D-L

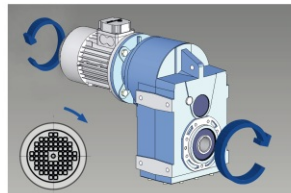

CLOCKWISE SENSE OF DIRECTION
REFERRED TO HIGH SPEED SHAFT

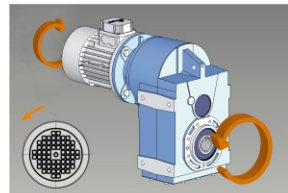

COUNTER CLOCKWISE SENSE OF DIRECTION
REFERRED TO HIGH SPEED SHAFT

	063	071	080	090	100-112	132	160	180	200	225
	140x11	160x14	200x19	200x24	250x28	300x38	350x42	350x48	400x55	450x60
S052		B5	B5	B5	B5					
S053	B5	B5	B5	B5						
S062		B5	B5	B5	B5					
S063		B5	B5	B5						
S082			B5	B5	B5	B5				
S083		B5	B5	B5	B5					
S102			B5	B5	B5	B5	B5			
S103		B5	B5	B5	B5					
S122			B5	B5	B5	B5	B5	B5	B5	
S123			B5	B5	B5	B5				
S142						B5	B5	B5	B5	
S143					B5	B5	B5			
S152							B5	B5	B5	B5
S153						B5	B5	B5		B5

4.5 OUTPUT SHAFT WITH SHRINK DISC

Clean and degrease the surfaces of the shaft to be fitted to. Comply with the indicated tightening torque of screws (M_T). The shrink disc is designed only to transmit the output torque. In case of radial and/or axial loads or V5-V6 mounting positions, please contact the technical support.

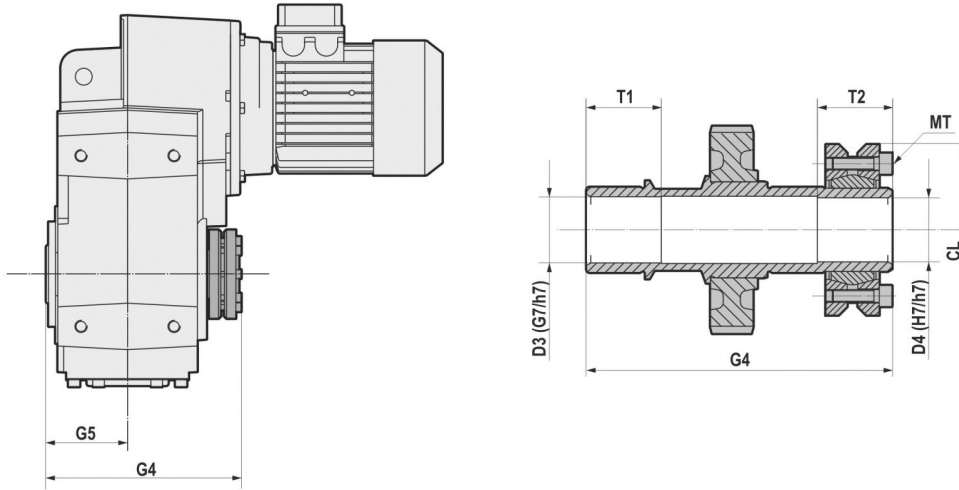

	D3	D4	G4	G5	T1	T2	CL	M_T 12.9 [Nm]
S052/S053	31	30	152	60	35	35	74	15
S062/S063	36	35	173	70	40	35	80	15
S082/S083	41	40	217	90	50	40	100	15
S102/S103	51	50	248	105	55	40	115	15
S122/S123	61	60	282	120	60	50	145	40

	D3 - D4 (H7/h6)	G4	CL	M_T 12.9 [Nm]
S142-S143	75	345	155	70
S152-S153	95	405	200	103
	80		185	

4.6 REINFORCED OIL SEALS FOR OUTPUT SHAFT

The reinforced seal can be done depending on the gearbox size by means of two oil seals or through the standard oil seal with VRM ring. The difference of the two solutions is explained on the drawings.

On request the gear reducer can be supplied with fluoroelastomer FPM (FKM) seals.

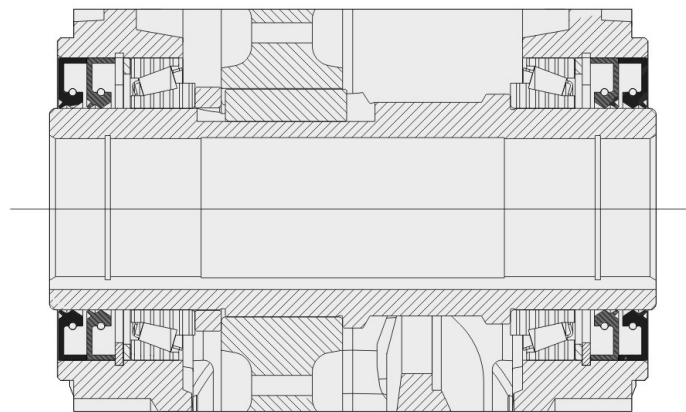
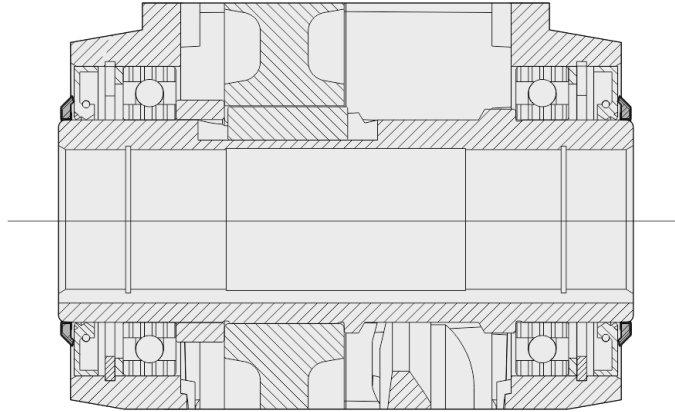

	Double oil seal	VRM ring
S050 2/3		x
S060 2/3		x
S080 2/3		x
S100 2/3		x
S125 2/3		x
S140 2/3		x
S150 2/3	x	

4.7 ASSEMBLING/DISASSEMBLING KIT

Mounting/dismounting kit for hollow shaft gear reducers with keyway that includes:

1. Retaining bolt
2. Circlip
3. Fixed nut
4. Forcing washer

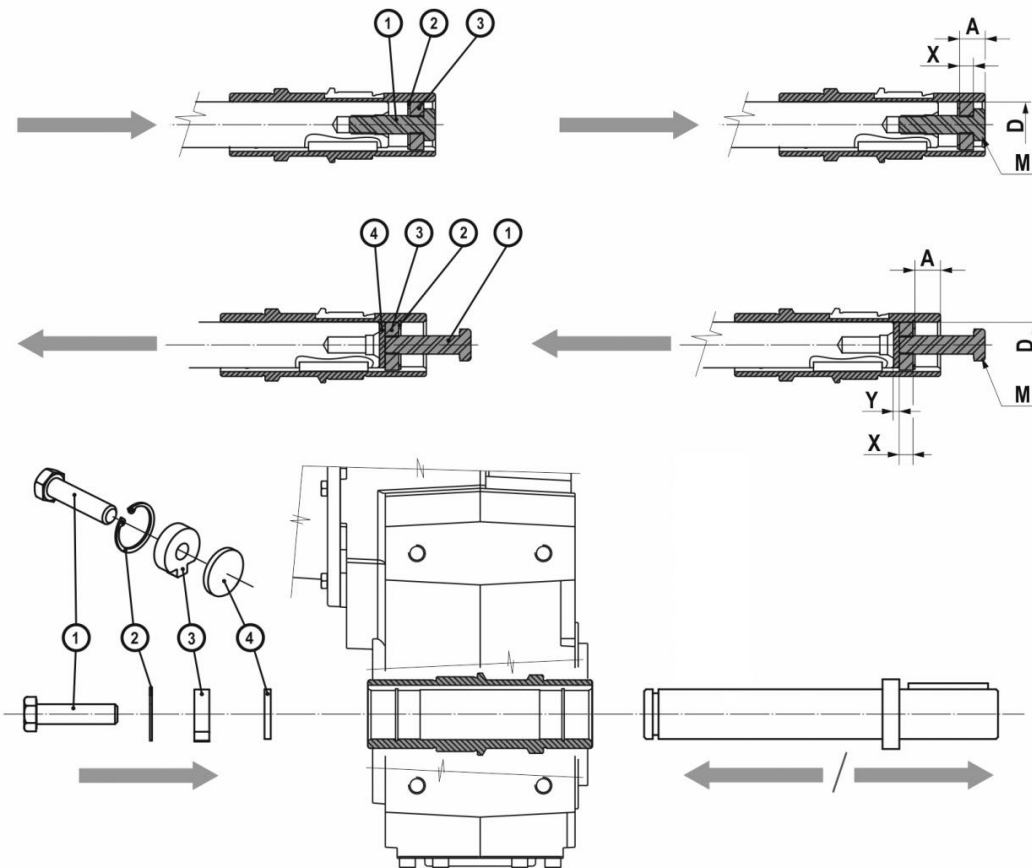

	D	A	X	Y	M
S052/S053	30	13,8	10	5	M10x35
S062/S063	35	12	12	5	M16x50
S082/S083	40	22,25	12	5	M16x50
	45				
S102/S103	50	25	12	5	M16x50
S122/S123	60	28	16	5	M20x70

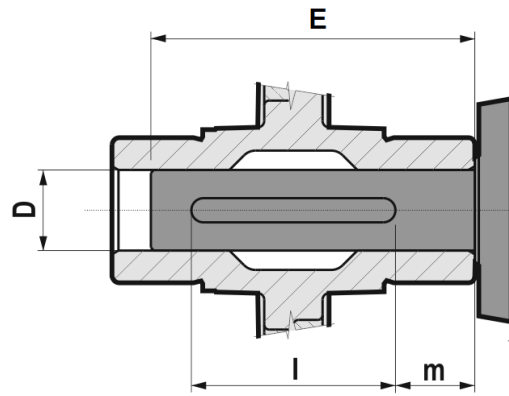

	D H7/h6	E*	l*	m*
S052/S053	30	91	60	12,5
S062/S063	35	108	80	12,5
S082/S083	40	140	100	17,5
	45			
S102/S103	50	165	120	20
S122/S123	60	185	140	22,5

(*) Suggested values.

0,09 kW

n2 [rpm]	M2 [Nm]	fs	i	Gear reducer	Size	Motor Pole	Fr2 D [N]	Fr2 C-L [N]
7,3	111	3,3	117,48	S053	63A	6	6000	6000
6,3	130	2,8	137,45	S053	63A	6	6000	6000
4,8	168	2,2	177,55	S053	63A	6	6000	6000
4,3	188	2,0	198,45	S053	63A	6	6000	6000
4,0	207	1,8	217,64	S053	63A	6	6000	6000
3,4	243	1,5	256,33	S053	63A	6	6000	6000
2,7	298	1,2	314,21	S053	63A	6	6000	6000

0,12 kW

n2 [rpm]	M2 [Nm]	fs	i	Gear reducer	Size	Motor Pole	Fr2 D [N]	Fr2 C-L [N]
11,7	93	3,9	74,20	S053	63B	6	6000	6000
11,5	93	3,7	117,48	S053	63A	4	6000	6000
11,1	98	3,7	78,14	S053	63B	6	6000	6000
9,8	110	3,2	137,45	S053	63A	4	6000	6000
9,1	120	3,0	95,84	S053	63B	6	6000	6000
7,6	142	2,5	177,55	S053	63A	4	6000	6000
7,4	147	2,5	117,48	S053	63B	6	6000	6000
6,9	159	2,2	198,45	S053	63A	4	6000	6000
6,4	172	2,1	137,45	S053	63B	6	6000	6000
6,2	174	2,0	217,64	S053	63A	4	6000	6000
5,2	204	1,7	256,33	S053	63A	4	6000	6000
4,9	222	1,6	177,55	S053	63B	6	6000	6000
4,3	248	1,5	198,45	S053	63B	6	6000	6000
4,3	251	1,4	314,21	S053	63A	4	6000	6000
4,0	272	1,3	217,64	S053	63B	6	6000	6000
3,4	320	1,1	256,33	S053	63B	6	6000	6000
2,7	393	0,9	314,21	S053	63B	6	6000	6000

0,18 kW

n2 [rpm]	M2 [Nm]	fs	i	Gear reducer	Size	Motor Pole	Fr2 D [N]	Fr2 C-L [N]
20,6	76	3,4	137,45	S053	63A	2	6000	6000
18,3	88	4,0	74,20	S053	63B	4	6000	6000
17,4	93	3,8	78,14	S053	63B	4	6000	6000
17,2	97	3,8	52,25	S052	71A	6	6000	6000
16,0	98	2,7	177,55	S053	63A	2	6000	6000
15,6	107	3,4	57,86	S052	71A	6	6000	6000
15,6	105	3,5	57,79	S053	71A	6	6000	6000
15,1	110	3,3	59,42	S052	71A	6	6000	6000
14,3	110	2,4	198,45	S053	63A	2	6000	6000

5.1 S GEARED MOTORS (50Hz)

0,18 kW

n2 [rpm]	M2 [Nm]	fs	i	Gear reducer	Size	Motor Pole	Fr2 D [N]	Fr2 C-L [N]
14,2	113	3,1	95,84	S053	63B	4	6000	6000
14,1	116	3,2	63,74	S053	71A	6	6000	6000
13,0	120	2,2	217,64	S053	63A	2	6000	6000
12,4	135	2,7	72,83	S052	71A	6	6000	6000
12,1	135	2,7	74,20	S053	71A	6	6000	6000
11,6	140	2,6	117,48	S053	63B	4	6000	6000
11,5	142	2,6	78,14	S053	71A	6	6000	6000
11,0	141	1,8	256,33	S053	63A	2	6000	6000
9,9	163	2,1	137,45	S053	63B	4	6000	6000
9,4	174	2,1	95,84	S053	71A	6	6000	6000
9,0	181	3,5	99,89	S063	71A	6	10000	4000
9,0	173	1,5	314,21	S053	63A	2	6000	6000
7,7	213	1,7	117,48	S053	71A	6	6000	6000
7,7	211	1,6	177,55	S053	63B	4	6000	6000
7,1	229	2,7	126,43	S063	71A	6	10000	4000
6,9	236	1,5	198,45	S053	63B	4	6000	6000
6,5	249	1,5	137,45	S053	71A	6	6000	6000
6,2	258	1,3	217,64	S053	63B	4	6000	6000
6,0	274	2,3	150,85	S063	71A	6	10000	4000
5,7	288	3,6	158,76	S083	71A	6	18000	7200
5,3	304	1,1	256,33	S053	63B	4	6000	6000
5,1	322	1,1	177,55	S053	71A	6	6000	6000
4,9	331	1,9	182,53	S063	71A	6	10000	4000
4,9	336	1,9	185,05	S063	71A	6	10000	4000
4,9	335	3,1	184,88	S083	71A	6	18000	7200
4,5	360	1,0	198,45	S053	71A	6	6000	6000
4,4	368	2,9	203,11	S083	71A	6	18000	7200
4,4	372	2,8	205,34	S083	71A	6	18000	7200
4,3	374	0,9	314,21	S053	63B	4	6000	6000
4,1	395	0,9	217,64	S053	71A	6	6000	6000
4,1	395	1,6	217,79	S063	71A	6	10000	4000
4,0	410	2,6	226,04	S083	71A	6	18000	7200
3,6	454	2,3	250,50	S083	71A	6	18000	7200
3,4	484	1,3	267,16	S063	71A	6	10000	4000
3,4	483	2,2	266,13	S083	71A	6	18000	7200
3,3	497	3,4	274,20	S103	71A	6	22000	9000
3,2	509	3,3	280,89	S103	71A	6	22000	9000
3,1	530	2,0	292,36	S083	71A	6	18000	7200
3,1	530	3,2	292,36	S103	71A	6	22000	9000
2,9	573	1,8	315,73	S083	71A	6	18000	7200
2,8	582	2,9	320,79	S103	71A	6	22000	9000
2,6	627	2,7	345,60	S103	71A	6	22000	9000

5.1 S GEARED MOTORS (50Hz)

0,18 kW

n2 [rpm]	M2 [Nm]	fs	i	Gear reducer	Size	Motor	Pole	Fr2 D [N]	Fr2 C-L [N]
2,5	654	1,6	360,58	S083	71A		6	18000	7200
2,3	716	2,3	394,69	S103	71A		6	22000	9000

0,25 kW

n2 [rpm]	M2 [Nm]	fs	i	Gear reducer	Size	Motor	Pole	Fr2 D [N]	Fr2 C-L [N]
30,3	76	3,9	30,00	S052	71B		6	6000	6000
29,4	73	3,5	95,84	S053	63B		2	6000	6000
27,9	83	3,8	32,55	S052	71B		6	6000	6000
27,6	84	3,7	33,00	S052	71B		6	6000	6000
26,7	87	3,6	34,09	S052	71B		6	6000	6000
25,0	91	4,0	36,50	S053	71B		6	6000	6000
24,9	93	3,7	36,55	S052	71B		6	6000	6000
24,0	90	2,9	117,48	S053	63B		2	6000	6000
23,8	96	3,7	57,86	S052	71A		4	6000	6000
23,5	99	3,5	38,75	S052	71B		6	6000	6000
23,3	96	3,7	57,79	S053	63D/71A		4	6000	6000
23,2	99	3,6	59,42	S052	71A		4	6000	6000
22,9	102	3,6	39,90	S052	71B		6	6000	6000
21,3	109	3,4	42,63	S052	71B		6	6000	6000
21,2	106	3,3	63,74	S053	63D/71A		4	6000	6000
20,5	105	2,5	137,45	S053	63B		2	6000	6000
19,8	117	3,1	46,00	S052	71B		6	6000	6000
19,3	120	3,0	47,20	S052	71B		6	6000	6000
19,3	118	3,1	47,14	S053	71B		6	6000	6000
19,0	121	2,9	72,83	S052	71A		4	6000	6000
18,2	123	2,9	74,20	S053	63D/71A		4	6000	6000
17,4	133	2,7	52,25	S052	71B		6	6000	6000
17,3	130	2,7	78,14	S053	63D/71A		4	6000	6000
15,9	136	1,9	177,55	S053	63B		2	6000	6000
15,8	147	2,5	57,86	S052	71B		6	6000	6000
15,8	144	2,5	57,79	S053	71B		6	6000	6000
15,3	151	2,4	59,42	S052	71B		6	6000	6000
14,3	159	2,3	63,74	S053	71B		6	6000	6000
14,2	152	1,7	198,45	S053	63B		2	6000	6000
14,1	159	2,1	95,84	S053	63D/71A		4	6000	6000
13,9	164	3,8	65,85	S063	71B		6	10000	4000
13,8	162	3,7	99,89	S063	71A		4	10000	4000
13,4	172	3,6	67,47	S062	71B		6	10000	4000
13,3	170	3,7	68,25	S063	71B		6	10000	4000
13,0	167	1,6	217,64	S053	63B		2	6000	6000
12,5	185	2,0	72,83	S052	71B		6	6000	6000

0,25 kW

n2 [rpm]	M2 [Nm]	fs	i	Gear reducer	Motor Size	Pole	Fr2 D [N]	Fr2 C-L [N]
12,3	183	3,4	73,63	S063	71B	6	10000	4000
12,2	185	2,0	74,20	S053	71B	6	6000	6000
11,6	195	1,9	78,14	S053	71B	6	6000	6000
11,5	196	1,8	117,48	S053	63D/71A	4	6000	6000
11,2	203	3,1	81,43	S063	71B	6	10000	4000
11,0	197	1,3	256,33	S053	63B	2	6000	6000
10,9	205	2,9	126,43	S063	71A	4	10000	4000
9,8	229	1,5	137,45	S053	63D/71A	4	6000	6000
9,5	238	1,5	95,84	S053	71B	6	6000	6000
9,1	246	2,5	150,85	S063	71A	4	10000	4000
9,1	249	2,5	99,89	S063	71B	6	10000	4000
9,0	241	1,1	314,21	S053	63B	2	6000	6000
8,7	258	3,9	158,76	S083	71A	4	18000	7200
7,8	293	1,2	117,48	S053	71B	6	6000	6000
7,8	292	3,6	117,17	S083	71B	6	18000	7200
7,6	295	1,2	177,55	S053	63D/71A	4	6000	6000
7,5	297	2,0	182,53	S063	71A	4	10000	4000
7,4	301	2,0	185,05	S063	71A	4	10000	4000
7,4	301	3,4	184,88	S083	71A	4	18000	7200
7,2	315	2,0	126,43	S063	71B	6	10000	4000
7,1	320	3,2	128,73	S083	71B	6	18000	7200
6,9	330	1,0	198,45	S053	63D/71A	4	6000	6000
6,8	330	3,0	203,11	S083	71A	4	18000	7200
6,8	334	3,0	205,34	S083	71A	4	18000	7200
6,7	339	3,1	136,34	S083	71B	6	18000	7200
6,6	342	1,1	137,45	S053	71B	6	6000	6000
6,4	355	1,7	217,79	S063	71A	4	10000	4000
6,2	362	0,9	217,64	S053	63D/71A	4	6000	6000
6,1	376	1,7	150,85	S063	71B	6	10000	4000
6,1	368	2,7	226,04	S083	71A	4	18000	7200
5,8	396	2,6	158,76	S083	71B	6	18000	7200
5,5	407	2,5	250,50	S083	71A	4	18000	7200
5,3	433	3,8	173,78	S103	71B	6	22000	9000
5,2	434	1,4	267,16	S063	71A	4	10000	4000
5,2	433	2,3	266,13	S083	71A	4	18000	7200
5,1	446	3,6	274,20	S103	71A	4	22000	9000
5,0	455	1,4	182,53	S063	71B	6	10000	4000
5,0	461	1,4	185,05	S063	71B	6	10000	4000
5,0	461	2,3	184,88	S083	71B	6	18000	7200
4,9	457	3,5	280,89	S103	71A	4	22000	9000
4,9	470	3,5	188,51	S103	71B	6	22000	9000
4,8	475	2,1	292,36	S083	71A	4	18000	7200

0,25 kW

n2 [rpm]	M2 [Nm]	fs	i	Gear reducer	Size	Motor Pole	Fr2 D [N]	Fr2 C-L [N]
4,8	475	3,4	292,36	S103	71A	4	22000	9000
4,4	506	2,1	203,11	S083	71B	6	18000	7200
4,4	511	2,0	205,34	S083	71B	6	18000	7200
4,4	506	3,3	203,11	S103	71B	6	22000	9000
4,4	514	2,0	315,73	S083	71A	4	18000	7200
4,3	522	3,1	320,79	S103	71A	4	22000	9000
4,1	543	1,1	217,79	S063	71B	6	10000	4000
4,0	563	1,8	226,04	S083	71B	6	18000	7200
4,0	555	3,0	222,85	S103	71B	6	22000	9000
4,0	560	3,0	224,76	S103	71B	6	22000	9000
4,0	562	2,9	345,60	S103	71A	4	22000	9000
3,9	586	1,7	360,58	S083	71A	4	18000	7200
3,6	624	1,7	250,50	S083	71B	6	18000	7200
3,5	642	2,5	394,69	S103	71A	4	22000	9000
3,4	666	0,9	267,16	S063	71B	6	10000	4000
3,4	663	1,6	266,13	S083	71B	6	18000	7200
3,3	683	2,4	274,20	S103	71B	6	22000	9000
3,2	699	2,4	280,89	S103	71B	6	22000	9000
3,1	728	1,4	292,36	S083	71B	6	18000	7200
3,1	728	2,3	292,36	S103	71B	6	22000	9000
2,9	786	1,3	315,73	S083	71B	6	18000	7200
2,8	799	2,1	320,79	S103	71B	6	22000	9000
2,6	861	1,9	345,60	S103	71B	6	22000	9000
2,5	898	1,2	360,58	S083	71B	6	18000	7200
2,3	983	1,7	394,69	S103	71B	6	22000	9000

0,37 kW

n2 [rpm]	M2 [Nm]	fs	i	Gear reducer	Size	Motor Pole	Fr2 D [N]	Fr2 C-L [N]
55,2	62	4,1	16,29	S052	71C	6	5904	5904
48,3	66	4,0	57,79	S053	63C	2	6000	6000
48,3	71	3,6	18,63	S052	71C/80A	6	6000	6000
46,7	73	4,0	30,00	S052	71B	4	6000	6000
45,6	75	3,4	19,73	S052	71C/80A	6	6000	6000
43,8	73	3,6	63,74	S053	63C	2	6000	6000
43,0	79	3,8	32,55	S052	71B	4	6000	6000
42,8	80	3,4	21,04	S052	71C/80A	6	6000	6000
42,4	80	3,8	33,00	S052	71B	4	6000	6000
41,8	82	3,4	21,53	S052	71C/80A	6	6000	6000
41,1	83	3,7	34,09	S052	71B	4	6000	6000
38,3	89	3,8	36,55	S052	71B	4	6000	6000
38,3	87	4,1	36,50	S053	71B	4	6000	6000

0,37 kW

n2 [rpm]	M2 [Nm]	fs	i	Gear reducer	Motor Size	Pole	Fr2 D [N]	Fr2 C-L [N]
37,6	85	3,1	74,20	S053	63C	2	6000	6000
37,4	92	3,0	24,07	S052	71C/80A	6	6000	6000
36,1	94	3,6	38,75	S052	71B	4	6000	6000
35,7	90	2,9	78,14	S053	63C	2	6000	6000
35,7	96	3,2	25,20	S052	71C/80A	6	6000	6000
35,1	97	3,7	39,90	S052	71B	4	6000	6000
34,9	98	3,1	25,79	S052	71C/80A	6	6000	6000
32,9	104	3,3	42,63	S052	71B	4	6000	6000
32,3	106	2,9	27,81	S052	71C/80A	6	6000	6000
30,4	111	3,1	46,00	S052	71B	4	6000	6000
30,0	114	2,7	30,00	S052	71C/80A	6	6000	6000
29,7	111	3,1	47,14	S053	71B	4	6000	6000
29,6	114	3,0	47,20	S052	71B	4	6000	6000
29,1	110	2,4	95,84	S053	63C	2	6000	6000
27,6	124	2,6	32,55	S052	71C/80A	6	6000	6000
27,3	125	2,6	33,00	S052	71C/80A	6	6000	6000
26,8	126	2,7	52,25	S052	71B	4	6000	6000
26,4	130	2,5	34,09	S052	71C/80A	6	6000	6000
24,6	139	2,5	36,55	S052	71C/80A	6	6000	6000
24,6	136	2,7	36,50	S053	71C/80A	6	6000	6000
24,2	137	2,5	57,79	S053	71B	4	6000	6000
24,1	140	2,5	57,86	S052	71B	4	6000	6000
23,7	135	1,9	117,48	S053	63C	2	6000	6000
23,5	144	2,4	59,42	S052	71B	4	6000	6000
23,2	148	2,4	38,75	S052	71C/80A	6	6000	6000
22,6	152	2,5	39,90	S052	71C/80A	6	6000	6000
21,9	151	2,3	63,74	S053	71B	4	6000	6000
21,3	156	3,9	65,85	S063	71B	4	10000	4000
21,1	162	2,2	42,63	S052	71C/80A	6	6000	6000
20,8	164	3,7	67,47	S062	71B	4	10000	4000
20,7	166	3,8	43,64	S062	71C/80A	6	10000	4000
20,5	162	3,8	68,25	S063	71B	4	10000	4000
20,3	158	1,7	137,45	S053	63C	2	6000	6000
19,5	175	2,1	46,00	S052	71C/80A	6	6000	6000
19,5	175	3,6	46,10	S062	71C/80A	6	10000	4000
19,2	176	2,0	72,83	S052	71B	4	6000	6000
19,1	176	2,0	47,14	S053	71C/80A	6	6000	6000
19,0	180	2,0	47,20	S052	71C/80A	6	6000	6000
19,0	174	3,4	73,63	S063	71B	4	10000	4000
18,9	176	2,0	74,20	S053	71B	4	6000	6000
18,6	184	3,5	48,30	S062	71C/80A	6	10000	4000
18,3	183	3,5	49,13	S063	71C/80A	6	10000	4000

0,37 kW

n2 [rpm]	M2 [Nm]	fs	i	Gear reducer	Motor Size	Pole	Fr2 D [N]	Fr2 C-L [N]
18,0	185	1,9	78,14	S053	71B	4	6000	6000
17,2	199	1,8	52,25	S052	71C/80A	6	6000	6000
17,1	193	3,1	81,43	S063	71B	4	10000	4000
16,8	203	3,1	53,53	S062	71C/80A	6	10000	4000
16,4	209	3,0	55,00	S062	71C/80A	6	10000	4000
16,3	206	3,1	55,29	S063	71C/80A	6	10000	4000
15,7	204	1,3	177,55	S053	63C	2	6000	6000
15,5	220	1,6	57,86	S052	71C/80A	6	6000	6000
15,5	215	1,7	57,79	S053	71C/80A	6	6000	6000
15,3	219	2,9	58,72	S063	71C/80A	6	10000	4000
15,1	226	1,6	59,42	S052	71C/80A	6	6000	6000
14,6	228	1,5	95,84	S053	71B	4	6000	6000
14,1	238	1,5	63,74	S053	71C/80A	6	6000	6000
14,1	228	1,2	198,45	S053	63C	2	6000	6000
14,0	237	2,5	99,89	S063	71B	4	10000	4000
13,7	245	2,6	65,85	S063	71C/80A	6	10000	4000
13,3	257	2,5	67,47	S062	71C/80A	6	10000	4000
13,2	254	2,5	68,25	S063	71C/80A	6	10000	4000
12,8	250	1,0	217,64	S053	63C	2	6000	6000
12,7	265	4,0	74,18	S083	80A	6	18000	7200
12,4	278	1,3	72,83	S052	71C/80A	6	6000	6000
12,3	275	2,2	73,63	S063	71C/80A	6	10000	4000
12,2	277	1,3	74,20	S053	71C/80A	6	6000	6000
12,0	278	3,6	117,17	S083	71B	4	18000	7200
11,9	279	1,2	117,48	S053	71B	4	6000	6000
11,6	291	1,2	78,14	S053	71C/80A	6	6000	6000
11,5	292	3,6	81,71	S083	80A	6	18000	7200
11,1	300	2,0	126,43	S063	71B	4	10000	4000
11,0	303	2,0	81,43	S063	71C/80A	6	10000	4000
10,9	306	3,2	128,73	S083	71B	4	18000	7200
10,3	327	3,2	91,49	S083	80A	6	18000	7200
10,2	323	3,0	136,34	S083	71B	4	18000	7200
10,1	326	1,1	137,45	S053	71B	4	6000	6000
9,4	357	1,0	95,84	S053	71C/80A	6	6000	6000
9,3	359	2,9	100,62	S083	80A	6	18000	7200
9,2	358	1,7	150,85	S063	71B	4	10000	4000
9,0	373	1,7	99,89	S063	71C/80A	6	10000	4000
8,8	377	2,6	158,76	S083	71B	4	18000	7200
8,2	412	4,1	110,55	S103	71C	6	22000	9000
8,0	412	3,9	173,78	S103	71B	4	22000	9000
7,7	433	1,4	182,53	S063	71B	4	10000	4000
7,7	437	2,5	117,17	S083	71C/80A	6	18000	7200

0,37 kW

n2 [rpm]	M2 [Nm]	fs	i	Gear reducer	Motor Size	Pole	Fr2 D [N]	Fr2 C-L [N]
7,6	439	1,3	185,05	S063	71B	4	10000	4000
7,6	439	2,2	184,88	S083	71B	4	18000	7200
7,5	452	3,7	121,29	S103	71C/80A	6	22000	9000
7,4	448	3,6	188,51	S103	71B	4	22000	9000
7,2	471	1,3	126,43	S063	71C/80A	6	10000	4000
7,0	480	2,1	128,73	S083	71C/80A	6	18000	7200
7,0	480	3,5	128,73	S103	71C/80A	6	22000	9000
6,9	482	2,0	203,11	S083	71B	4	18000	7200
6,9	482	3,3	203,11	S103	71B	4	22000	9000
6,8	487	2,0	205,34	S083	71B	4	18000	7200
6,6	508	2,0	136,34	S083	71C/80A	6	18000	7200
6,4	517	1,1	217,79	S063	71B	4	10000	4000
6,3	526	3,2	141,24	S103	71C/80A	6	22000	9000
6,3	528	3,0	222,85	S103	71B	4	22000	9000
6,2	536	1,8	226,04	S083	71B	4	18000	7200
6,2	533	3,0	224,76	S103	71B	4	22000	9000
5,9	562	1,1	150,85	S063	71C/80A	6	10000	4000
5,6	592	1,7	158,76	S083	71C/80A	6	18000	7200
5,6	594	1,7	250,50	S083	71B	4	18000	7200
5,3	634	0,9	267,16	S063	71B	4	10000	4000
5,3	632	1,6	266,13	S083	71B	4	18000	7200
5,2	647	2,6	173,78	S103	71C/80A	6	22000	9000
5,1	660	1,0	185,05	S063	80A	6	10000	4000
5,1	651	2,4	274,20	S103	71B	4	22000	9000
5,0	666	2,4	280,89	S103	71B	4	22000	9000
4,9	681	0,9	182,53	S063	71C/80A	6	10000	4000
4,9	689	1,5	184,88	S083	71C/80A	6	18000	7200
4,8	703	2,4	188,51	S103	71C/80A	6	22000	9000
4,8	694	1,4	292,36	S083	71B	4	18000	7200
4,8	694	2,3	292,36	S103	71B	4	22000	9000
4,5	749	1,3	315,73	S083	71B	4	18000	7200
4,4	757	1,4	203,11	S083	71C/80A	6	18000	7200
4,4	766	1,3	205,34	S083	71C/80A	6	18000	7200
4,4	757	2,2	203,11	S103	71C/80A	6	22000	9000
4,4	761	2,1	320,79	S103	71B	4	22000	9000
4,1	820	1,9	345,60	S103	71B	4	22000	9000
4,0	843	1,2	226,04	S083	71C/80A	6	18000	7200
4,0	831	2,0	222,85	S103	71C/80A	6	22000	9000
4,0	838	2,0	224,76	S103	71C/80A	6	22000	9000
3,9	853	3,7	238,93	S123	80A	6	30000	11200
3,9	856	1,2	360,58	S083	71B	4	18000	7200
3,7	912	3,5	255,54	S123	80A	6	30000	11200

0,37 kW

n2 [rpm]	M2 [Nm]	fs	i	Gear reducer	Size	Motor Pole	Fr2 D [N]	Fr2 C-L [N]
3,6	934	1,1	250,50	S083	71C/80A	6	18000	7200
3,6	936	1,7	394,69	S103	71B	4	22000	9000
3,4	1000	3,2	280,10	S123	80A	6	30000	11200
3,4	993	1,0	266,13	S083	71C/80A	6	18000	7200
3,3	1022	1,6	274,20	S103	71C/80A	6	22000	9000
3,2	1047	1,6	280,89	S103	71C/80A	6	22000	9000
3,1	1075	2,9	301,16	S123	80A	6	30000	11200
3,1	1090	0,9	292,36	S083	71C/80A	6	18000	7200
3,1	1090	1,5	292,36	S103	71C/80A	6	22000	9000
3,0	1127	0,9	315,73	S083	80A	6	18000	7200
2,8	1196	1,4	320,79	S103	71C/80A	6	22000	9000
2,7	1227	2,6	343,93	S123	80A	6	30000	11200
2,6	1288	1,3	345,60	S103	71C/80A	6	22000	9000
2,2	1472	1,1	394,69	S103	71C/80A	6	22000	9000

0,55 kW

n2 [rpm]	M2 [Nm]	fs	i	Gear reducer	Size	Motor Pole	Fr2 D [N]	Fr2 C-L [N]
109,0	47	3,8	8,63	S052	80B	6	4719	4719
86,9	56	4,0	32,55	S052	71B	2	5046	5046
85,8	57	3,9	33,00	S052	71B	2	5066	5066
84,4	60	3,3	11,14	S052	80B	6	5079	5079
83,0	59	3,8	34,09	S052	71B	2	5113	5113
78,3	65	3,2	12,00	S052	80B	6	5187	5187
77,4	63	3,9	36,55	S052	71B	2	5215	5215
75,1	68	3,6	18,63	S052	71C/80A	4	5267	5267
73,0	67	3,7	38,75	S052	71B	2	5302	5302
70,9	71	3,4	19,73	S052	71C/80A	4	5352	5352
70,9	69	3,8	39,90	S052	71B	2	5346	5346
68,8	74	2,9	13,66	S052	80B	6	5377	5377
66,5	75	3,5	21,04	S052	71C/80A	4	5448	5448
66,4	73	3,6	42,63	S052	71B	2	5445	5445
65,0	77	3,4	21,53	S052	71C/80A	4	5482	5482
61,6	83	3,0	15,27	S052	80B	6	5544	5544
61,5	79	3,3	46,00	S052	71B	2	5561	5561
60,0	79	3,3	47,14	S053	71B	2	5608	5608
59,9	81	3,2	47,20	S052	71B	2	5600	5600
58,1	87	3,0	24,07	S052	71C/80A	4	5651	5651
57,7	88	2,8	16,29	S052	80B	6	5641	5641
55,6	91	3,2	25,20	S052	71C/80A	4	5721	5721
54,3	93	3,2	25,79	S052	71C/80A	4	5756	5756
54,2	89	2,9	52,25	S052	71B	2	5756	5756

0,55 kW

n2 [rpm]	M2 [Nm]	fs	i	Gear reducer	Motor Size	Pole	Fr2 D [N]	Fr2 C-L [N]
50,4	101	2,5	18,63	S052	80B	6	5846	5846
50,4	100	2,9	27,81	S052	71C/80A	4	5872	5872
48,9	99	2,6	57,86	S052	71B	2	5915	5915
48,9	97	2,7	57,79	S053	71B	2	5925	5925
47,6	102	2,6	59,42	S052	71B	2	5956	5956
47,6	107	2,3	19,73	S052	80B	6	5933	5933
46,7	108	2,7	30,00	S052	71C/80A	4	5989	5989
44,7	114	2,4	21,04	S052	80B	6	6000	6000
44,4	107	2,4	63,74	S053	71B	2	6000	6000
43,7	117	2,3	21,53	S052	80B	6	6000	6000
43,0	117	2,6	32,55	S052	71C/80A	4	6000	6000
42,4	118	2,6	33,00	S052	71C/80A	4	6000	6000
42,0	116	3,9	67,47	S062	71B	2	10000	4000
41,5	115	3,9	68,25	S063	71B	2	10000	4000
41,1	122	2,5	34,09	S052	71C/80A	4	6000	6000
40,5	126	3,9	23,18	S062	80B	6	10000	4000
39,6	129	3,8	23,75	S062	80B	6	10000	4000
39,0	131	2,1	24,07	S052	80B	6	6000	6000
38,9	125	2,1	72,83	S052	71B	2	6000	6000
38,5	124	3,6	73,63	S063	71B	2	10000	4000
38,3	132	2,6	36,55	S052	71C/80A	4	6000	6000
38,3	129	2,8	36,50	S053	71C/80A	4	6000	6000
38,2	125	2,1	74,20	S053	71B	2	6000	6000
37,4	137	3,7	25,14	S062	80B	6	10000	4000
37,3	137	2,2	25,20	S052	80B	6	6000	6000
36,5	140	2,2	25,79	S052	80B	6	6000	6000
36,3	131	2,0	78,14	S053	71B	2	6000	6000
36,2	140	2,4	38,75	S052	71C/80A	4	6000	6000
35,1	144	2,5	39,90	S052	71C/80A	4	6000	6000
34,7	137	3,3	81,43	S063	71B	2	10000	4000
34,0	149	3,3	27,66	S062	80B	6	10000	4000
33,8	150	2,0	27,81	S052	80B	6	6000	6000
32,8	154	2,2	42,63	S052	71C/80A	4	6000	6000
32,1	158	3,8	43,64	S062	71C/80A	4	10000	4000
31,3	162	1,9	30,00	S052	80B	6	6000	6000
31,3	162	3,2	30,00	S062	80B	6	10000	4000
30,5	165	2,1	46,00	S052	71C/80A	4	6000	6000
30,4	166	3,6	46,10	S062	71C/80A	4	10000	4000
29,7	166	2,1	47,14	S053	71C/80A	4	6000	6000
29,6	170	2,0	47,20	S052	71C/80A	4	6000	6000
29,5	162	1,6	95,84	S053	71B	2	6000	6000
29,0	174	3,5	48,30	S062	71C/80A	4	10000	4000

0,55 kW

n2 [rpm]	M2 [Nm]	fs	i	Gear reducer	Motor Size	Pole	Fr2 D [N]	Fr2 C-L [N]
28,9	176	1,8	32,55	S052	80B	6	6000	6000
28,5	173	3,5	49,13	S063	71C/80A	4	10000	4000
28,5	179	1,7	33,00	S052	80B	6	6000	6000
28,3	168	2,7	99,89	S063	71B	2	10000	4000
28,0	178	3,5	33,57	S063	80B	6	10000	4000
27,7	184	3,1	33,93	S062	80B	6	10000	4000
27,6	185	1,7	34,09	S052	80B	6	6000	6000
26,8	188	1,8	52,25	S052	71C/80A	4	6000	6000
26,2	193	3,1	53,53	S062	71C/80A	4	10000	4000
25,8	194	1,9	36,50	S053	80B	6	6000	6000
25,7	198	1,7	36,55	S052	80B	6	6000	6000
25,7	198	3,1	36,57	S062	80B	6	10000	4000
25,4	198	3,1	55,00	S062	71C/80A	4	10000	4000
25,3	195	3,1	55,29	S063	71C/80A	4	10000	4000
24,9	201	3,1	37,77	S063	80B	6	10000	4000
24,3	210	1,6	38,75	S052	80B	6	6000	6000
24,2	208	1,6	57,86	S052	71C/80A	4	6000	6000
24,2	204	1,7	57,79	S053	71C/80A	4	6000	6000
24,2	198	3,8	117,17	S083	71B	2	18000	7200
24,1	198	1,3	117,48	S053	71B	2	6000	6000
23,9	214	2,9	39,38	S062	80B	6	10000	4000
23,8	207	2,9	58,72	S063	71C/80A	4	10000	4000
23,6	214	1,6	59,42	S052	71C/80A	4	6000	6000
23,6	216	1,7	39,90	S052	80B	6	6000	6000
23,4	213	2,9	40,05	S063	80B	6	10000	4000
22,4	212	2,1	126,43	S063	71B	2	10000	4000
22,0	231	1,6	42,63	S052	80B	6	6000	6000
22,0	225	1,5	63,74	S053	71C/80A	4	6000	6000
22,0	216	3,4	128,73	S083	71B	2	18000	7200
21,5	236	2,6	43,64	S062	80B	6	10000	4000
21,3	232	2,6	65,85	S063	71C/80A	4	10000	4000
20,7	229	3,2	136,34	S083	71B	2	18000	7200
20,7	243	2,5	67,47	S062	71C/80A	4	10000	4000
20,5	231	1,1	137,45	S053	71B	2	6000	6000
20,5	241	2,5	68,25	S063	71C/80A	4	10000	4000
20,4	249	1,5	46,00	S052	80B	6	6000	6000
20,4	249	2,5	46,10	S062	80B	6	10000	4000
19,9	255	1,4	47,20	S052	80B	6	6000	6000
19,9	250	1,5	47,14	S053	80B	6	6000	6000
19,5	261	2,4	48,30	S062	80B	6	10000	4000
19,2	262	1,3	72,83	S052	71C/80A	4	6000	6000
19,2	258	3,9	74,18	S083	80A	4	18000	7200

0,55 kW

n2 [rpm]	M2 [Nm]	fs	i	Gear reducer	Motor Size	Pole	Fr2 D [N]	Fr2 C-L [N]
19,1	260	2,4	49,13	S063	80B	6	10000	4000
19,0	259	2,4	73,63	S063	71C/80A	4	10000	4000
18,9	261	1,3	74,20	S053	71C/80A	4	6000	6000
18,7	254	1,8	150,85	S063	71B	2	10000	4000
18,7	272	3,8	50,25	S082	80B	6	18000	7200
18,0	283	1,3	52,25	S052	80B	6	6000	6000
17,9	276	1,2	78,14	S053	71C/80A	4	6000	6000
17,8	267	2,8	158,76	S083	71B	2	18000	7200
17,6	290	2,1	53,53	S062	80B	6	10000	4000
17,3	284	3,5	81,71	S083	80A	4	18000	7200
17,3	294	3,5	54,27	S082	80B	6	18000	7200
17,2	287	2,0	81,43	S063	71C/80A	4	10000	4000
17,1	298	2,1	55,00	S062	80B	6	10000	4000
17,0	293	2,1	55,29	S063	80B	6	10000	4000
16,3	314	1,2	57,86	S052	80B	6	6000	6000
16,3	307	1,2	57,79	S053	80B	6	6000	6000
16,0	312	2,0	58,72	S063	80B	6	10000	4000
15,9	322	1,1	59,42	S052	80B	6	6000	6000
15,5	318	3,1	91,49	S083	80A	4	18000	7200
15,5	307	1,5	182,53	S063	71B	2	10000	4000
15,3	312	1,4	185,05	S063	71B	2	10000	4000
15,3	311	2,4	184,88	S083	71B	2	18000	7200
15,2	335	3,1	61,98	S082	80B	6	18000	7200
15,0	318	3,8	188,51	S103	71B	2	22000	9000
14,8	338	1,1	63,74	S053	80B	6	6000	6000
14,6	338	1,0	95,84	S053	71C/80A	4	6000	6000
14,3	349	1,8	65,85	S063	80B	6	10000	4000
14,1	350	2,8	100,62	S083	80A	4	18000	7200
14,0	352	1,7	99,89	S063	71C/80A	4	10000	4000
13,9	365	1,7	67,47	S062	80B	6	10000	4000
13,9	358	2,9	67,52	S083	80B	6	18000	7200
13,9	342	2,2	203,11	S083	71B	2	18000	7200
13,9	342	3,5	203,11	S103	71B	2	22000	9000
13,8	346	2,2	205,34	S083	71B	2	18000	7200
13,7	362	1,7	68,25	S063	80B	6	10000	4000
13,0	366	1,2	217,79	S063	71B	2	10000	4000
12,9	395	0,9	72,83	S052	80B	6	6000	6000
12,7	391	1,6	73,63	S063	80B	6	10000	4000
12,7	375	3,2	222,85	S103	71B	2	22000	9000
12,6	394	0,9	74,20	S053	80B	6	6000	6000
12,6	394	2,6	74,18	S083	80B	6	18000	7200
12,6	378	3,1	224,76	S103	71B	2	22000	9000

0,55 kW

n2 [rpm]	M2 [Nm]	fs	i	Gear reducer	Motor Size	Pole	Fr2 D [N]	Fr2 C-L [N]
12,5	380	2,0	226,04	S083	71B	2	18000	7200
12,0	413	2,5	117,17	S083	71C/80A	4	18000	7200
11,5	428	3,8	121,29	S103	71C/80A	4	22000	9000
11,5	432	1,4	81,43	S063	80B	6	10000	4000
11,5	433	2,4	81,71	S083	80B	6	18000	7200
11,5	431	3,8	81,39	S103	80B	6	22000	9000
11,3	422	1,8	250,50	S083	71B	2	18000	7200
11,0	446	1,3	126,43	S063	71C/80A	4	10000	4000
10,8	454	2,2	128,73	S083	71C/80A	4	18000	7200
10,8	454	3,5	128,73	S103	71C/80A	4	22000	9000
10,7	448	1,7	266,13	S083	71B	2	18000	7200
10,5	476	3,5	89,77	S103	80B	6	22000	9000
10,3	486	2,1	91,49	S083	80B	6	18000	7200
10,3	462	2,6	274,20	S103	71B	2	22000	9000
10,2	480	2,0	136,34	S083	71C/80A	4	18000	7200
10,1	473	2,5	280,89	S103	71B	2	22000	9000
9,9	498	3,2	141,24	S103	71C/80A	4	22000	9000
9,7	493	1,5	292,36	S083	71B	2	18000	7200
9,7	493	2,4	292,36	S103	71B	2	22000	9000
9,4	530	1,2	99,89	S063	80B	6	10000	4000
9,4	531	3,1	100,15	S103	80B	6	22000	9000
9,3	532	1,1	150,85	S063	71C/80A	4	10000	4000
9,3	534	1,9	100,62	S083	80B	6	18000	7200
9,0	531	1,4	315,73	S083	71B	2	18000	7200
8,9	540	2,2	320,79	S103	71B	2	22000	9000
8,8	560	1,7	158,76	S083	71C/80A	4	18000	7200
8,5	587	2,8	110,55	S103	80B	6	22000	9000
8,2	582	2,0	345,60	S103	71B	2	22000	9000
8,1	613	2,7	173,78	S103	71C/80A	4	22000	9000
8,0	621	1,7	117,17	S083	80B	6	18000	7200
7,9	607	1,2	360,58	S083	71B	2	18000	7200
7,8	643	2,6	121,29	S103	80B	6	22000	9000
7,7	644	0,9	185,05	S063	80A	4	10000	4000
7,7	644	0,9	182,53	S063	71C/80A	4	10000	4000
7,6	652	1,5	184,88	S083	71C/80A	4	18000	7200
7,5	671	0,9	126,43	S063	80B	6	10000	4000
7,5	664	2,5	188,51	S103	71C/80A	4	22000	9000
7,3	683	1,5	128,73	S083	80B	6	18000	7200
7,3	683	2,4	128,73	S103	80B	6	22000	9000
7,2	664	1,8	394,69	S103	71B	2	22000	9000
6,9	723	1,4	136,34	S083	80B	6	18000	7200
6,8	716	1,4	203,11	S083	71C/80A	4	18000	7200

0,55 kW

n2 [rpm]	M2 [Nm]	fs	i	Gear reducer	Motor Size	Pole	Fr2 D [N]	Fr2 C-L [N]
6,8	724	1,4	205,34	S083	71C/80A	4	18000	7200
6,8	716	2,2	203,11	S103	71C/80A	4	22000	9000
6,7	749	2,2	141,24	S103	80B	6	22000	9000
6,6	749	4,0	215,60	S123	80A	4	30000	11200
6,2	798	1,2	226,04	S083	71C/80A	4	18000	7200
6,2	786	2,0	222,85	S103	71C/80A	4	22000	9000
6,2	793	2,0	224,76	S103	71C/80A	4	22000	9000
6,2	803	3,9	151,43	S123	80B	6	30000	11200
6,0	831	3,7	238,93	S123	80A	4	30000	11200
6,0	842	1,2	158,76	S083	80B	6	18000	7200
5,6	884	1,1	250,50	S083	71C/80A	4	18000	7200
5,6	888	3,3	255,54	S123	80A	4	30000	11200
5,5	922	1,8	173,78	S103	80B	6	22000	9000
5,3	942	3,3	177,53	S123	80B	6	30000	11200
5,2	938	1,0	266,13	S083	71C/80A	4	18000	7200
5,1	967	1,6	274,20	S103	71C/80A	4	22000	9000
5,1	974	3,0	280,10	S123	80A	4	30000	11200
5,1	981	1,1	184,88	S083	80B	6	18000	7200
5,0	990	1,6	280,89	S103	71C/80A	4	22000	9000
5,0	1000	1,7	188,51	S103	80B	6	22000	9000
4,9	1032	3,0	194,59	S123	80B	6	30000	11200
4,8	1031	0,9	292,36	S083	71C/80A	4	18000	7200
4,8	1031	1,5	292,36	S103	71C/80A	4	22000	9000
4,7	1047	2,8	301,16	S123	80A	4	30000	11200
4,6	1077	1,0	203,11	S083	80B	6	18000	7200
4,6	1077	1,5	203,11	S103	80B	6	22000	9000
4,5	1089	1,0	205,34	S083	80B	6	18000	7200
4,4	1131	1,4	320,79	S103	71C/80A	4	22000	9000
4,3	1144	2,7	215,60	S123	80B	6	30000	11200
4,2	1182	1,4	222,85	S103	80B	6	22000	9000
4,2	1196	2,5	343,93	S123	80A	4	30000	11200
4,1	1192	1,4	224,76	S103	80B	6	22000	9000
4,1	1219	1,3	345,60	S103	71C/80A	4	22000	9000
3,9	1267	2,5	238,93	S123	80B	6	30000	11200
3,6	1356	2,3	255,54	S123	80B	6	30000	11200
3,6	1392	1,1	394,69	S103	71C/80A	4	22000	9000
3,4	1454	1,1	274,20	S103	80B	6	22000	9000
3,3	1490	1,1	280,89	S103	80B	6	22000	9000
3,3	1486	2,1	280,10	S123	80B	6	30000	11200
3,2	1551	1,1	292,36	S103	80B	6	22000	9000
3,1	1598	2,0	301,16	S123	80B	6	30000	11200
2,9	1702	1,0	320,79	S103	80B	6	22000	9000

5.1 S GEARED MOTORS (50Hz)

0,55 kW

n2 [rpm]	M2 [Nm]	fs	i	Gear reducer	Size	Motor Pole	Fr2 D [N]	Fr2 C-L [N]
2,7	1833	0,9	345,60	S103	80B	6	22000	9000
2,7	1825	1,7	343,93	S123	80B	6	30000	11200

0,75 kW

n2 [rpm]	M2 [Nm]	fs	i	Gear reducer	Size	Motor Pole	Fr2 D [N]	Fr2 C-L [N]
144,9	46	4,0	19,73	S052	80A	2	4284	4284
136,0	49	4,0	21,04	S052	80A	2	4364	4364
132,8	50	3,9	21,53	S052	80A	2	4393	4393
129,3	54	3,5	11,14	S052	80B	4	4403	4403
120,0	58	3,5	12,00	S052	80B	4	4496	4496
118,9	56	3,5	24,07	S052	80A	2	4534	4534
113,5	59	3,8	25,20	S052	80A	2	4593	4593
110,9	60	3,6	25,79	S052	80A	2	4600	4600
109,0	64	2,8	8,63	S052	90S	6	4606	4606
105,4	66	3,2	13,66	S052	80B	4	4660	4660
102,8	65	3,4	27,81	S052	80A	2	4697	4697
95,3	70	3,1	30,00	S052	80A	2	4796	4796
94,3	73	3,3	15,27	S052	80B	4	4796	4796
88,4	78	3,1	16,29	S052	80B	4	4880	4880
87,9	76	3,0	32,55	S052	80A	2	4904	4904
86,7	77	2,9	33,00	S052	80A	2	4922	4922
84,4	82	2,5	11,14	S052	90S	6	4964	4964
83,9	79	2,8	34,09	S052	80A	2	4974	4974
78,4	83	3,2	36,50	S053	80A	2	5066	5066
78,4	89	2,3	12,00	S052	90S	6	5062	5062
78,3	85	2,9	36,55	S052	80A	2	5058	5058
77,2	89	2,7	18,63	S052	80B	4	5094	5094
73,8	90	2,7	38,75	S052	80A	2	5160	5160
73,0	94	2,5	19,73	S052	80B	4	5142	5142
71,7	93	2,8	39,90	S052	80A	2	5176	5176
68,8	101	2,2	13,66	S052	90S	6	5205	5205
68,5	100	2,6	21,04	S052	80B	4	5227	5227
67,1	99	2,6	42,63	S052	80A	2	5275	5275
66,9	103	2,5	21,53	S052	80B	4	5258	5258
62,2	107	2,4	46,00	S052	80A	2	5392	5392
61,5	113	2,2	15,27	S052	90S	6	5353	5353
60,6	107	2,4	47,14	S053	80A	2	5425	5425
60,6	110	2,4	47,20	S052	80A	2	5403	5403
59,8	115	2,2	24,07	S052	80B	4	5406	5406
59,2	112	4,0	48,30	S062	80A	2	9772	3909
59,0	117	4,0	15,94	S062	90S	6	9788	3915

0,75 kW

n2 [rpm]	M2 [Nm]	fs	i	Gear reducer	Size	Motor Pole	Fr2 D [N]	Fr2 C-L [N]
58,2	112	4,1	49,13	S063	80A	2	9863	3945
58,1	119	4,0	16,16	S062	90S	6	9827	3931
57,7	120	2,0	16,29	S052	90S	6	5467	5467
57,3	120	4,0	25,14	S062	80B	4	9837	3935
57,2	121	2,4	25,20	S052	80B	4	5496	5496
55,9	123	2,4	25,79	S052	80B	4	5527	5527
54,8	121	2,2	52,25	S052	80A	2	5551	5551
53,5	124	3,6	53,53	S062	80A	2	10000	4000
52,0	132	3,6	27,66	S062	80B	4	10000	4000
52,0	128	3,5	55,00	S062	80A	2	10000	4000
51,7	133	2,2	27,81	S052	80B	4	5627	5627
51,7	126	3,6	55,29	S063	80A	2	10000	4000
50,5	138	1,8	18,63	S052	90S	6	5616	5616
49,5	135	1,9	57,86	S052	80A	2	5703	5703
49,5	132	2,0	57,79	S053	80A	2	5718	5718
48,8	134	3,4	58,72	S063	80A	2	10000	4000
48,7	143	3,3	19,29	S062	90S	6	10000	4000
48,1	138	1,9	59,42	S052	80A	2	5725	5725
48,1	145	3,4	19,55	S062	90S	6	10000	4000
48,0	143	2,0	30,00	S052	80B	4	5699	5699
48,0	143	3,5	30,00	S062	80B	4	10000	4000
47,6	146	1,7	19,73	S052	90S	6	5691	5691
44,9	145	1,8	63,74	S053	80A	2	5828	5828
44,6	156	1,7	21,04	S052	90S	6	5803	5803
44,2	156	1,9	32,55	S052	80B	4	5806	5806
43,6	160	1,7	21,53	S052	90S	6	5833	5833
43,6	158	1,9	33,00	S052	80B	4	5815	5815
43,4	150	3,0	65,85	S063	80A	2	10000	4000
42,9	157	3,8	33,57	S063	80B	4	10000	4000
42,5	162	3,3	33,93	S062	80B	4	10000	4000
42,4	157	2,9	67,47	S062	80A	2	10000	4000
42,2	163	1,8	34,09	S052	80B	4	5857	5857
41,9	155	3,0	68,25	S063	80A	2	10000	4000
40,6	171	2,9	23,18	S062	90S	6	10000	4000
39,5	175	2,9	23,75	S062	90S	6	10000	4000
39,5	171	2,1	36,50	S053	80B	4	6000	6000
39,4	175	1,9	36,55	S052	80B	4	5947	5947
39,4	175	3,4	36,57	S062	80B	4	10000	4000
39,3	169	1,6	72,83	S052	80A	2	5987	5987
39,0	178	1,5	24,07	S052	90S	6	5976	5976
38,9	167	2,6	73,63	S063	80A	2	10000	4000
38,5	169	1,6	74,20	S053	80A	2	6000	6000

0,75 kW

n2 [rpm]	M2 [Nm]	fs	i	Gear reducer	Size	Motor Pole	Fr2 D [N]	Fr2 C-L [N]
38,1	177	3,4	37,77	S063	80B	4	10000	4000
37,4	186	2,7	25,14	S062	90S	6	10000	4000
37,3	186	1,6	25,20	S052	90S	6	6000	6000
37,2	185	1,8	38,75	S052	80B	4	6000	6000
36,6	178	1,5	78,14	S053	80A	2	6000	6000
36,6	188	3,2	39,38	S062	80B	4	10000	4000
36,5	191	1,6	25,79	S052	90S	6	6000	6000
36,1	191	1,8	39,90	S052	80B	4	6000	6000
35,9	188	3,2	40,05	S063	80B	4	10000	4000
35,1	185	2,4	81,43	S063	80A	2	10000	4000
35,0	186	4,1	81,71	S083	80A	2	18000	6781
34,0	205	2,5	27,66	S062	90S	6	10000	4000
33,8	206	1,5	27,81	S052	90S	6	6000	6000
33,8	204	1,7	42,63	S052	80B	4	6000	6000
33,0	209	2,9	43,64	S062	80B	4	10000	4000
31,3	222	1,4	30,00	S052	90S	6	6000	6000
31,3	220	1,6	46,00	S052	80B	4	6000	6000
31,3	222	2,4	30,00	S062	90S	6	10000	4000
31,2	208	3,6	91,49	S083	80A	2	18000	7025
31,2	220	2,7	46,10	S062	80B	4	10000	4000
30,5	226	1,5	47,20	S052	80B	4	6000	6000
30,5	221	1,5	47,14	S053	80B	4	6000	6000
29,8	218	1,2	95,84	S053	80A	2	6000	6000
29,8	231	2,6	48,30	S062	80B	4	10000	4000
29,3	230	2,6	49,13	S063	80B	4	10000	4000
28,9	241	1,3	32,55	S052	90S	6	6000	6000
28,6	227	2,0	99,89	S063	80A	2	10000	4000
28,5	244	1,3	33,00	S052	90S	6	6000	6000
28,4	229	3,3	100,62	S083	80A	2	18000	7196
28,0	243	2,6	33,57	S063	90S	6	10000	4000
27,7	251	2,3	33,93	S062	90S	6	10000	4000
27,6	252	1,3	34,09	S052	90S	6	6000	6000
27,6	250	1,4	52,25	S052	80B	4	6000	6000
27,0	258	4,1	34,91	S082	90S	6	18000	7200
26,9	256	2,3	53,53	S062	80B	4	10000	4000
26,5	260	3,9	54,27	S082	80B	4	18000	7200
26,5	262	4,0	35,50	S082	90S	6	18000	7200
26,2	263	2,3	55,00	S062	80B	4	10000	4000
26,0	259	2,4	55,29	S063	80B	4	10000	4000
25,7	270	1,3	36,55	S052	90S	6	6000	6000
25,7	264	1,4	36,50	S053	90S	6	6000	6000
25,7	270	2,3	36,57	S062	90S	6	10000	4000

0,75 kW

n2 [rpm]	M2 [Nm]	fs	i	Gear reducer	Size	Motor Pole	Fr2 D [N]	Fr2 C-L [N]
24,9	273	2,3	37,77	S063	90S	6	10000	4000
24,9	276	1,2	57,86	S052	80B	4	6000	6000
24,9	270	1,3	57,79	S053	80B	4	6000	6000
24,5	275	2,2	58,72	S063	80B	4	10000	4000
24,4	266	2,8	117,17	S083	80A	2	18000	7200
24,3	284	1,2	59,42	S052	80B	4	6000	6000
24,2	287	1,2	38,75	S052	90S	6	6000	6000
23,9	291	2,2	39,38	S062	90S	6	10000	4000
23,6	295	1,2	39,90	S052	90S	6	6000	6000
23,5	290	2,2	40,05	S063	90S	6	10000	4000
23,5	296	3,5	40,05	S082	90S	6	18000	7200
23,2	296	3,4	61,98	S082	80B	4	18000	7200
22,6	298	1,1	63,74	S053	80B	4	6000	6000
22,6	287	1,6	126,43	S063	80A	2	10000	4000
22,2	293	2,5	128,73	S083	80A	2	18000	7200
22,1	315	1,1	42,63	S052	90S	6	6000	6000
21,9	308	2,0	65,85	S063	80B	4	10000	4000
21,9	318	3,3	43,05	S082	90S	6	18000	7200
21,5	322	2,0	43,64	S062	90S	6	10000	4000
21,3	322	1,9	67,47	S062	80B	4	10000	4000
21,3	316	3,2	67,52	S083	80B	4	18000	7200
21,1	319	1,9	68,25	S063	80B	4	10000	4000
21,0	310	2,4	136,34	S083	80A	2	18000	7200
20,4	340	1,1	46,00	S052	90S	6	6000	6000
20,4	341	1,8	46,10	S062	90S	6	10000	4000
20,3	321	3,8	141,24	S103	80A	2	22000	9000
19,9	349	1,1	47,20	S052	90S	6	6000	6000
19,9	341	1,1	47,14	S053	90S	6	6000	6000
19,7	348	1,0	72,83	S052	80B	4	6000	6000
19,5	345	1,7	73,63	S063	80B	4	10000	4000
19,4	347	1,0	74,20	S053	80B	4	6000	6000
19,4	347	2,9	74,18	S083	80B	4	18000	7200
19,4	357	1,7	48,30	S062	90S	6	10000	4000
19,1	355	1,7	49,13	S063	90S	6	10000	4000
19,0	343	1,3	150,85	S063	80A	2	10000	4000
18,7	371	2,8	50,25	S082	90S	6	18000	7200
18,7	371	4,0	50,25	S102	90S	6	22000	9000
18,4	366	0,9	78,14	S053	80B	4	6000	6000
18,0	386	1,0	52,25	S052	90S	6	6000	6000
18,0	361	2,1	158,76	S083	80A	2	18000	7200
17,7	381	1,5	81,43	S063	80B	4	10000	4000
17,6	382	2,6	81,71	S083	80B	4	18000	7200

0,75 kW

n2 [rpm]	M2 [Nm]	fs	i	Gear reducer	Size	Motor Pole	Fr2 D [N]	Fr2 C-L [N]
17,6	395	1,6	53,53	S062	90S	6	10000	4000
17,4	401	2,7	54,27	S082	90S	6	18000	7200
17,1	406	1,5	55,00	S062	90S	6	10000	4000
17,1	407	3,4	55,14	S102	90S	6	22000	9000
17,0	400	1,5	55,29	S063	90S	6	10000	4000
16,4	395	3,0	173,78	S103	80A	2	22000	9000
16,0	420	3,8	89,77	S103	80B	4	22000	9000
16,0	425	1,5	58,72	S063	90S	6	10000	4000
15,8	439	3,8	59,40	S102	90S	6	22000	9000
15,7	415	1,1	182,53	S063	80A	2	10000	4000
15,7	428	2,3	91,49	S083	80B	4	18000	7200
15,5	420	1,8	184,88	S083	80A	2	18000	7200
15,5	421	1,1	185,05	S063	80A	2	10000	4000
15,2	428	2,8	188,51	S103	80A	2	22000	9000
15,1	458	2,2	61,98	S082	90S	6	18000	7200
14,4	467	1,3	99,89	S063	80B	4	10000	4000
14,4	469	3,4	100,15	S103	80B	4	22000	9000
14,3	477	1,3	65,85	S063	90S	6	10000	4000
14,3	471	2,1	100,62	S083	80B	4	18000	7200
14,0	462	1,6	203,11	S083	80A	2	18000	7200
14,0	462	2,6	203,11	S103	80A	2	22000	9000
13,9	467	1,6	205,34	S083	80A	2	18000	7200
13,9	498	1,2	67,47	S062	90S	6	10000	4000
13,9	488	2,1	67,52	S083	90S	6	18000	7200
13,9	501	3,4	67,84	S102	90S	6	22000	9000
13,8	494	1,3	68,25	S063	90S	6	10000	4000
13,1	517	3,1	110,55	S103	80B	4	22000	9000
12,8	533	1,2	73,63	S063	90S	6	10000	4000
12,8	506	2,4	222,85	S103	80A	2	22000	9000
12,7	537	2,0	74,18	S083	90S	6	18000	7200
12,7	537	3,1	74,18	S103	90S	6	22000	9000
12,7	511	2,4	224,76	S103	80A	2	22000	9000
12,6	514	1,4	226,04	S083	80A	2	18000	7200
12,2	548	1,9	117,17	S083	80B	4	18000	7200
11,9	567	2,8	121,29	S103	80B	4	22000	9000
11,5	589	1,0	81,43	S063	90S	6	10000	4000
11,5	591	1,7	81,71	S083	90S	6	18000	7200
11,5	589	2,9	81,39	S103	90S	6	22000	9000
11,4	591	1,0	126,43	S063	80B	4	10000	4000
11,4	569	1,3	250,50	S083	80A	2	18000	7200
11,2	602	1,7	128,73	S083	80B	4	18000	7200
11,2	602	2,7	128,73	S103	80B	4	22000	9000

0,75 kW

n2 [rpm]	M2 [Nm]	fs	i	Gear reducer	Motor Size	Pole	Fr2 D [N]	Fr2 C-L [N]
11,2	581	3,9	255,54	S123	80A	2	30000	11200
10,7	605	1,2	266,13	S083	80A	2	18000	7200
10,6	638	1,5	136,34	S083	80B	4	18000	7200
10,5	649	2,6	89,77	S103	90S	6	22000	9000
10,4	623	1,9	274,20	S103	80A	2	22000	9000
10,3	662	1,6	91,49	S083	90S	6	18000	7200
10,2	637	3,6	280,10	S123	80A	2	30000	11200
10,2	639	1,9	280,89	S103	80A	2	22000	9000
10,2	660	2,4	141,24	S103	80B	4	22000	9000
9,8	664	1,1	292,36	S083	80A	2	18000	7200
9,8	664	1,8	292,36	S103	80A	2	22000	9000
9,5	684	3,3	301,16	S123	80A	2	30000	11200
9,4	724	2,3	100,15	S103	90S	6	22000	9000
9,3	728	1,4	100,62	S083	90S	6	18000	7200
9,1	717	1,0	315,73	S083	80A	2	18000	7200
9,1	743	1,3	158,76	S083	80B	4	18000	7200
9,0	729	1,6	320,79	S103	80A	2	22000	9000
8,5	800	2,1	110,55	S103	90S	6	22000	9000
8,4	814	3,9	112,52	S123	90S	6	30000	11200
8,4	782	2,9	343,93	S123	80A	2	30000	11200
8,3	813	2,0	173,78	S103	80B	4	22000	9000
8,3	785	1,5	345,60	S103	80A	2	22000	9000
8,1	830	3,6	177,53	S123	80B	4	30000	11200
8,0	848	1,2	117,17	S083	90S	6	18000	7200
7,8	864	1,1	184,88	S083	80B	4	18000	7200
7,8	878	1,9	121,29	S103	90S	6	22000	9000
7,7	893	3,6	123,33	S123	90S	6	30000	11200
7,7	882	1,8	188,51	S103	80B	4	22000	9000
7,4	910	3,3	194,59	S123	80B	4	30000	11200
7,3	931	1,1	128,73	S083	90S	6	18000	7200
7,3	931	1,8	128,73	S103	90S	6	22000	9000
7,2	897	1,3	394,69	S103	80A	2	22000	9000
7,2	941	3,3	130,04	S123	90S	6	30000	11200
7,1	950	1,1	203,11	S083	80B	4	18000	7200
7,1	950	1,7	203,11	S103	80B	4	22000	9000
7,0	960	1,0	205,34	S083	80B	4	18000	7200
7,0	968	3,3	133,78	S123	90S	6	30000	11200
6,8	987	1,0	136,34	S083	90S	6	18000	7200
6,7	1022	1,6	141,24	S103	90S	6	22000	9000
6,7	1008	3,0	215,60	S123	80B	4	30000	11200
6,5	1042	1,5	222,85	S103	80B	4	22000	9000
6,4	1057	0,9	226,04	S083	80B	4	18000	7200

0,75 kW

n2 [rpm]	M2 [Nm]	fs	i	Gear reducer	Size	Motor Pole	Fr2 D [N]	Fr2 C-L [N]
6,4	1051	1,5	224,76	S103	80B	4	22000	9000
6,2	1095	2,9	151,43	S123	90S	6	30000	11200
6,0	1117	2,7	238,93	S123	80B	4	30000	11200
5,9	1149	0,9	158,76	S083	90S	6	18000	7200
5,6	1195	2,5	255,54	S123	80B	4	30000	11200
5,4	1257	1,3	173,78	S103	90S	6	22000	9000
5,3	1284	2,5	177,53	S123	90S	6	30000	11200
5,2	1282	1,2	274,20	S103	80B	4	22000	9000
5,1	1314	1,2	280,89	S103	80B	4	22000	9000
5,1	1310	2,3	280,10	S123	80B	4	30000	11200
5,0	1364	1,2	188,51	S103	90S	6	22000	9000
4,9	1367	1,2	292,36	S103	80B	4	22000	9000
4,8	1408	2,2	194,59	S123	90S	6	30000	11200
4,7	1408	2,1	301,16	S123	80B	4	30000	11200
4,6	1469	1,1	203,11	S103	90S	6	22000	9000
4,5	1500	1,0	320,79	S103	80B	4	22000	9000
4,4	1560	2,0	215,60	S123	90S	6	30000	11200
4,2	1608	1,9	343,93	S123	80B	4	30000	11200
4,2	1612	1,0	222,85	S103	90S	6	22000	9000
4,2	1626	1,0	224,76	S103	90S	6	22000	9000
4,2	1616	1,0	345,60	S103	80B	4	22000	9000
4,0	1728	1,8	238,93	S123	90S	6	30000	11200
3,7	1849	1,7	255,54	S123	90S	6	30000	11200
3,4	2026	1,6	280,10	S123	90S	6	30000	11200
3,1	2179	1,4	301,16	S123	90S	6	30000	11200
2,7	2488	1,3	343,93	S123	90S	6	30000	11200

1,10 kW

n2 [rpm]	M2 [Nm]	fs	i	Gear reducer	Size	Motor Pole	Fr2 D [N]	Fr2 C-L [N]
256,7	38	3,8	11,14	S052	80B	2	3530	3530
238,3	41	3,7	12,00	S052	80B	2	3606	3606
209,5	47	3,4	13,66	S052	80B	2	3749	3749
187,3	52	3,4	15,27	S052	80B	2	3871	3871
175,6	56	3,2	16,29	S052	80B	2	3937	3937
165,8	61	2,8	8,63	S052	90S	4	3979	3979
153,5	64	2,8	18,63	S052	80B	2	4083	4083
145,0	68	2,7	19,73	S052	80B	2	4146	4146
136,0	72	2,7	21,04	S052	80B	2	4210	4210
132,8	73	2,6	21,53	S052	80B	2	4243	4243
128,4	79	2,4	11,14	S052	90S	4	4258	4258
119,2	85	2,4	12,00	S052	90S	4	4340	4340

1,10 kW

n2 [rpm]	M2 [Nm]	fs	i	Gear reducer	Motor Size	Pole	Fr2 D [N]	Fr2 C-L [N]
118,8	82	2,4	24,07	S052	80B	2	4372	4372
113,5	86	2,5	25,20	S052	80B	2	4423	4423
111,0	88	2,5	25,79	S052	80B	2	4449	4449
110,1	92	1,9	8,63	S052	100LR	6	4421	4421
106,5	96	3,6	8,92	S062	100LR	6	8014	3206
104,7	96	2,2	13,66	S052	90S	4	4482	4482
103,4	94	3,8	27,66	S062	80B	2	8124	3250
102,8	95	2,3	27,81	S052	80B	2	4522	4522
99,5	102	3,7	9,55	S062	100LR	6	8166	3267
95,4	102	2,1	30,00	S052	80B	2	4615	4615
95,4	102	3,6	30,00	S062	80B	2	8310	3324
93,6	108	2,2	15,27	S052	90S	4	4606	4606
89,7	113	4,0	15,94	S062	90S	4	8458	3383
89,2	114	3,3	10,65	S062	100LR	6	8415	3366
88,5	114	3,9	16,16	S062	90S	4	8442	3377
87,9	111	2,0	32,55	S052	80B	2	4707	4707
87,8	115	2,1	16,29	S052	90S	4	4676	4676
86,7	112	2,0	33,00	S052	80B	2	4722	4722
85,3	119	1,7	11,14	S052	100LR	6	4702	4702
85,2	112	4,0	33,57	S063	80B	2	8587	3435
84,3	116	3,5	33,93	S062	80B	2	8604	3442
83,9	116	1,9	34,09	S052	80B	2	4759	4759
81,1	126	3,3	11,71	S062	100LR	6	8634	3454
79,2	129	1,6	12,00	S052	100LR	6	4782	4782
78,4	122	2,2	36,50	S053	80B	2	4842	4842
78,2	125	2,0	36,55	S052	80B	2	4840	4840
78,2	125	3,6	36,57	S062	80B	2	8781	3513
76,7	131	1,8	18,63	S052	90S	4	4846	4846
75,7	126	3,6	37,77	S063	80B	2	8867	3547
74,2	136	3,3	19,29	S062	90S	4	8902	3561
73,8	132	1,9	38,75	S052	80B	2	4901	4901
73,1	138	3,4	19,55	S062	90S	4	8934	3574
72,8	140	3,1	13,06	S062	100LR	6	8888	3555
72,6	134	3,3	39,38	S062	80B	2	8948	3579
72,5	139	1,7	19,73	S052	90S	4	4907	4907
71,7	136	1,9	39,90	S052	80B	2	4933	4933
71,4	134	3,3	40,05	S063	80B	2	9015	3606
71,1	143	3,1	13,36	S062	100LR	6	8941	3576
69,6	146	1,5	13,66	S052	100LR	6	4920	4920
68,0	149	1,7	21,04	S052	90S	4	4975	4975
67,1	145	1,8	42,63	S052	80B	2	5009	5009
66,4	152	1,7	21,53	S052	90S	4	4977	4977

1,10 kW

n2 [rpm]	M2 [Nm]	fs	i	Gear reducer	Motor Size	Pole	Fr2 D [N]	Fr2 C-L [N]
65,6	149	3,0	43,64	S062	80B	2	9194	3677
62,2	164	1,5	15,27	S052	100LR	6	5036	5036
62,2	157	1,7	46,00	S052	80B	2	5079	5079
62,1	157	2,8	46,10	S062	80B	2	9334	3734
61,7	164	2,9	23,18	S062	90S	4	9336	3734
60,6	157	1,7	47,14	S053	80B	2	5136	5136
60,6	161	1,6	47,20	S052	80B	2	5107	5107
60,2	167	2,8	23,75	S062	90S	4	9394	3758
59,6	171	2,8	15,94	S062	100LR	6	9357	3743
59,4	170	1,5	24,07	S052	90S	4	5093	5093
59,2	165	2,7	48,30	S062	80B	2	9438	3775
58,8	173	2,7	16,16	S062	100LR	6	9390	3756
58,3	175	1,4	16,29	S052	100LR	6	5101	5101
58,2	164	2,7	49,13	S063	80B	2	9484	3794
56,9	177	2,8	25,14	S062	90S	4	9529	3812
56,8	178	1,6	25,20	S052	90S	4	5160	5160
55,5	182	1,6	25,79	S052	90S	4	5183	5183
54,8	178	1,5	52,25	S052	80B	2	5224	5224
53,5	182	2,4	53,53	S062	80B	2	9695	3878
52,0	187	2,4	55,00	S062	80B	2	9760	3904
51,7	184	2,4	55,29	S063	80B	2	9798	3919
51,7	195	2,5	27,66	S062	90S	4	9705	3882
51,4	196	1,5	27,81	S052	90S	4	5236	5236
51,0	200	1,3	18,63	S052	100LR	6	5233	5233
49,9	204	4,0	19,03	S082	100LR	6	18000	5962
49,5	193	1,4	57,79	S053	80B	2	5338	5338
49,4	197	1,3	57,86	S052	80B	2	5316	5316
49,3	207	2,3	19,29	S062	100LR	6	9807	3923
48,7	196	2,3	58,72	S063	80B	2	9919	3968
48,6	210	2,3	19,55	S062	100LR	6	9839	3936
48,2	212	1,2	19,73	S052	100LR	6	5286	5286
48,1	203	1,3	59,42	S052	80B	2	5348	5348
47,7	212	1,4	30,00	S052	90S	4	5308	5308
47,7	212	2,4	30,00	S062	90S	4	9898	3959
47,2	216	3,7	20,14	S082	100LR	6	18000	6067
46,1	211	3,6	61,98	S082	80B	2	18000	6117
45,2	226	1,2	21,04	S052	100LR	6	5345	5345
44,9	213	1,2	63,74	S053	80B	2	5445	5445
44,1	231	1,2	21,53	S052	100LR	6	5365	5365
43,9	230	1,3	32,55	S052	90S	4	5382	5382
43,5	220	2,0	65,85	S063	80B	2	10000	4000
43,3	233	1,3	33,00	S052	90S	4	5413	5413

5.1 S GEARED MOTORS (50Hz)

1,10 kW

n2 [rpm]	M2 [Nm]	fs	i	Gear reducer	Motor Size	Pole	Fr2 D [N]	Fr2 C-L [N]
42,9	237	3,5	22,13	S082	100LR	6	18000	6244
42,6	232	2,6	33,57	S063	90S	4	10000	4000
42,4	230	2,0	67,47	S062	80B	2	10000	4000
42,4	225	3,3	67,52	S083	80B	2	18000	6299
42,2	239	2,3	33,93	S062	90S	4	10000	4000
42,0	241	1,2	34,09	S052	90S	4	5440	5440
41,9	228	2,0	68,25	S063	80B	2	10000	4000
41,0	249	2,0	23,18	S062	100LR	6	10000	4000
41,0	246	4,1	34,91	S082	90S	4	18000	6378
40,2	251	4,0	35,50	S082	90S	4	18000	6411
40,0	255	1,9	23,75	S062	100LR	6	10000	4000
39,6	257	3,3	24,00	S082	100LR	6	18000	6402
39,5	258	1,1	24,07	S052	100LR	6	5458	5458
39,3	248	1,1	72,83	S052	80B	2	5535	5535
39,2	252	1,4	36,50	S053	90S	4	5510	5510
39,1	258	1,3	36,55	S052	90S	4	5480	5480
39,1	258	2,3	36,57	S062	90S	4	10000	4000
38,8	245	1,8	73,63	S063	80B	2	10000	4000
38,5	247	1,1	74,20	S053	80B	2	5585	5585
38,5	247	3,0	74,18	S083	80B	2	18000	6490
37,9	261	2,3	37,77	S063	90S	4	10000	4000
37,8	270	1,9	25,14	S062	100LR	6	10000	4000
37,7	270	1,1	25,20	S052	100LR	6	5494	5494
36,9	273	1,2	38,75	S052	90S	4	5542	5542
36,8	276	1,1	25,79	S052	100LR	6	5511	5511
36,6	260	1,0	78,14	S053	80B	2	5626	5626
36,5	279	3,0	26,05	S082	100LR	6	18000	6563
36,4	278	2,1	39,38	S062	90S	4	10000	4000
35,8	281	1,2	39,90	S052	90S	4	5548	5548
35,8	277	2,1	40,05	S063	90S	4	10000	4000
35,8	283	3,6	40,05	S082	90S	4	18000	6650
35,2	271	1,6	81,43	S063	80B	2	10000	4000
35,0	272	2,7	81,71	S083	80B	2	18000	6684
34,8	293	3,2	27,29	S082	100LR	6	18000	6656
34,4	297	1,7	27,66	S062	100LR	6	10000	4000
34,2	298	1,0	27,81	S052	100LR	6	5565	5565
33,5	301	1,2	42,63	S052	90S	4	5594	5594
33,2	304	3,3	43,05	S082	90S	4	18000	6754
33,1	307	3,1	28,67	S082	100LR	6	18000	6756
32,8	308	1,9	43,64	S062	90S	4	10000	4000
32,1	317	3,0	29,60	S082	100LR	6	18000	6821
31,8	299	4,0	89,77	S103	80B	2	22000	8481

1,10 kW

n2 [rpm]	M2 [Nm]	fs	i	Gear reducer	Motor Size	Pole	Fr2 D [N]	Fr2 C-L [N]
31,7	322	1,6	30,00	S062	100LR	6	10000	4000
31,3	305	2,5	91,49	S083	80B	2	18000	6895
31,1	324	1,1	46,00	S052	90S	4	5655	5655
31,1	325	1,8	46,10	S062	90S	4	10000	4000
30,3	326	1,1	47,14	S053	90S	4	5710	5710
30,3	333	1,1	47,20	S052	90S	4	5658	5658
29,9	341	3,1	31,78	S082	100LR	6	18000	6968
29,6	341	1,8	48,30	S062	90S	4	10000	4000
29,2	349	0,9	32,55	S052	100LR	6	5659	5659
29,1	340	1,7	49,13	S063	90S	4	10000	4000
28,6	333	1,4	99,89	S063	80B	2	10000	4000
28,6	334	3,6	100,15	S103	80B	2	22000	8756
28,5	354	2,9	50,25	S082	90S	4	18000	7120
28,5	354	4,0	50,25	S102	90S	4	22000	8809
28,4	336	2,2	100,62	S083	80B	2	18000	7111
28,0	364	1,6	33,93	S062	100LR	6	10000	4000
27,4	368	0,9	52,25	S052	90S	4	5719	5719
27,2	374	2,8	34,91	S082	100LR	6	18000	7166
27,2	374	3,9	34,91	S102	100LR	6	22000	8870
26,8	381	2,8	35,50	S082	100LR	6	18000	7200
26,8	378	1,6	53,53	S062	90S	4	10000	4000
26,4	383	2,6	54,27	S082	90S	4	18000	7200
26,0	392	1,6	36,57	S062	100LR	6	10000	4000
26,0	388	1,5	55,00	S062	90S	4	10000	4000
25,9	382	1,6	55,29	S063	90S	4	10000	4000
25,9	389	3,3	55,14	S102	90S	4	22000	9000
25,9	368	3,2	110,55	S103	80B	2	22000	9000
24,8	411	3,8	38,30	S102	100LR	6	22000	9000
24,5	391	1,9	117,17	S083	80B	2	18000	7200
24,3	405	1,4	58,72	S063	90S	4	10000	4000
24,1	419	3,8	59,40	S102	90S	4	22000	9000
24,1	422	1,5	39,38	S062	100LR	6	10000	4000
23,7	429	2,4	40,05	S082	100LR	6	18000	7200
23,6	404	2,9	121,29	S103	80B	2	22000	9000
23,1	437	2,3	61,98	S082	90S	4	18000	7200
22,6	422	1,1	126,43	S063	80B	2	10000	4000
22,3	456	3,2	42,53	S102	100LR	6	22000	9000
22,2	429	1,7	128,73	S083	80B	2	18000	7200
22,2	429	2,8	128,73	S103	80B	2	22000	9000
22,1	462	2,3	43,05	S082	100LR	6	18000	7200
21,8	468	1,3	43,64	S062	100LR	6	10000	4000
21,7	455	1,3	65,85	S063	90S	4	10000	4000

5.1 S GEARED MOTORS (50Hz)

1,10 kW

n2 [rpm]	M2 [Nm]	fs	i	Gear reducer	Motor Size	Pole	Fr2 D [N]	Fr2 C-L [N]
21,6	472	2,9	44,00	S102	100LR	6	22000	9000
21,2	476	1,3	67,47	S062	90S	4	10000	4000
21,1	466	2,1	67,52	S083	90S	4	18000	7200
21,0	479	3,4	67,84	S102	90S	4	22000	9000
21,0	454	1,6	136,34	S083	80B	2	18000	7200
21,0	471	1,3	68,25	S063	90S	4	10000	4000
20,2	471	2,5	141,24	S103	80B	2	22000	9000
20,2	505	3,3	47,13	S102	100LR	6	22000	9000
19,7	518	1,2	48,30	S062	100LR	6	10000	4000
19,4	508	1,2	73,63	S063	90S	4	10000	4000
19,3	512	1,9	74,18	S083	90S	4	18000	7200
19,3	512	3,2	74,18	S103	90S	4	22000	9000
18,9	539	1,9	50,25	S082	100LR	6	18000	7200
18,9	539	2,7	50,25	S102	100LR	6	22000	9000
18,0	529	1,4	158,76	S083	80B	2	18000	7200
17,7	574	1,1	53,53	S062	100LR	6	10000	4000
17,6	562	1,1	81,43	S063	90S	4	10000	4000
17,6	562	2,8	81,39	S103	90S	4	22000	9000
17,5	582	1,8	54,27	S082	100LR	6	18000	7200
17,5	564	1,8	81,71	S083	90S	4	18000	7200
17,2	591	2,3	55,14	S102	100LR	6	22000	9000
16,5	579	2,1	173,78	S103	80B	2	22000	9000
16,1	592	3,8	177,53	S123	80B	2	30000	11200
16,0	637	2,6	59,40	S102	100LR	6	22000	9000
15,9	620	2,6	89,77	S103	90S	4	22000	9000
15,6	632	1,6	91,49	S083	90S	4	18000	7200
15,5	616	1,2	184,88	S083	80B	2	18000	7200
15,3	664	1,6	61,98	S082	100LR	6	18000	7200
15,2	629	1,9	188,51	S103	80B	2	22000	9000
14,7	648	3,4	194,59	S123	80B	2	30000	11200
14,3	692	2,3	100,15	S103	90S	4	22000	9000
14,2	695	1,4	100,62	S083	90S	4	18000	7200
14,1	709	1,5	67,52	S083	100LR	6	18000	7200
14,1	677	1,1	203,11	S083	80B	2	18000	7200
14,1	677	1,8	203,11	S103	80B	2	22000	9000
14,0	727	2,3	67,84	S102	100LR	6	22000	9000
13,9	684	1,1	205,34	S083	80B	2	18000	7200
13,4	746	3,8	71,07	S123	100LR	6	30000	11200
13,2	718	3,1	215,60	S123	80B	2	30000	11200
13,0	764	2,1	110,55	S103	90S	4	22000	9000
12,8	779	1,3	74,18	S083	100LR	6	18000	7200
12,8	779	2,2	74,18	S103	100LR	6	22000	9000

1,10 kW

n2 [rpm]	M2 [Nm]	fs	i	Gear reducer	Motor Size	Pole	Fr2 D [N]	Fr2 C-L [N]
12,8	743	1,6	222,85	S103	80B	2	22000	9000
12,7	749	1,6	224,76	S103	80B	2	22000	9000
12,7	777	3,9	112,52	S123	90S	4	30000	11200
12,2	809	1,2	117,17	S083	90S	4	18000	7200
12,1	824	3,8	78,46	S123	100LR	6	30000	11200
11,9	797	2,8	238,93	S123	80B	2	30000	11200
11,7	838	1,9	121,29	S103	90S	4	22000	9000
11,7	855	2,0	81,39	S103	100LR	6	22000	9000
11,6	858	1,2	81,71	S083	100LR	6	18000	7200
11,6	852	3,5	123,33	S123	90S	4	30000	11200
11,2	851	2,6	255,54	S123	80B	2	30000	11200
11,1	889	1,1	128,73	S083	90S	4	18000	7200
11,1	889	1,8	128,73	S103	90S	4	22000	9000
11,0	898	3,3	130,04	S123	90S	4	30000	11200
10,9	916	3,4	87,27	S123	100LR	6	30000	11200
10,7	924	3,3	133,78	S123	90S	4	30000	11200
10,6	942	1,8	89,77	S103	100LR	6	22000	9000
10,5	942	1,0	136,34	S083	90S	4	18000	7200
10,4	961	1,1	91,49	S083	100LR	6	18000	7200
10,4	914	1,3	274,20	S103	80B	2	22000	9000
10,2	936	1,3	280,89	S103	80B	2	22000	9000
10,2	933	2,4	280,10	S123	80B	2	30000	11200
10,1	975	1,6	141,24	S103	90S	4	22000	9000
9,8	974	1,2	292,36	S103	80B	2	22000	9000
9,5	1051	1,6	100,15	S103	100LR	6	22000	9000
9,5	1003	2,2	301,16	S123	80B	2	30000	11200
9,4	1056	1,0	100,62	S083	100LR	6	18000	7200
9,4	1046	2,9	151,43	S123	90S	4	30000	11200
9,0	1096	0,9	158,76	S083	90S	4	18000	7200
9,0	1112	2,8	105,91	S123	100LR	6	30000	11200
8,9	1069	1,1	320,79	S103	80B	2	22000	9000
8,6	1161	1,4	110,55	S103	100LR	6	22000	9000
8,4	1181	2,7	112,52	S123	100LR	6	30000	11200
8,3	1146	2,0	343,93	S123	80B	2	30000	11200
8,3	1200	1,3	173,78	S103	90S	4	22000	9000
8,3	1152	1,0	345,60	S103	80B	2	22000	9000
8,1	1226	2,4	177,53	S123	90S	4	30000	11200
7,8	1273	1,3	121,29	S103	100LR	6	22000	9000
7,7	1295	2,4	123,33	S123	100LR	6	30000	11200
7,7	1296	3,9	123,44	S143	100LR	6	35000	18500
7,6	1302	1,2	188,51	S103	90S	4	22000	9000
7,4	1351	1,2	128,73	S103	100LR	6	22000	9000

1,10 kW

n2 [rpm]	M2 [Nm]	fs	i	Gear reducer	Size	Motor Pole	Fr2 D [N]	Fr2 C-L [N]
7,3	1365	2,3	130,04	S123	100LR	6	30000	11200
7,3	1344	2,2	194,59	S123	90S	4	30000	11200
7,1	1404	2,2	133,78	S123	100LR	6	30000	11200
7,0	1403	1,1	203,11	S103	90S	4	22000	9000
6,8	1466	3,5	139,64	S143	100LR	6	35000	18500
6,7	1483	1,1	141,24	S103	100LR	6	22000	9000
6,6	1489	2,0	215,60	S123	90S	4	30000	11200
6,4	1539	1,0	222,85	S103	90S	4	22000	9000
6,4	1552	1,0	224,76	S103	90S	4	22000	9000
6,4	1565	3,2	149,10	S143	100LR	6	35000	18500
6,3	1590	2,0	151,43	S123	100LR	6	30000	11200
6,0	1650	1,8	238,93	S123	90S	4	30000	11200
6,0	1653	2,4	157,49	S143	100LR	6	35000	18500
5,6	1765	1,7	255,54	S123	90S	4	30000	11200
5,5	1824	0,9	173,78	S103	100LR	6	22000	9000
5,5	1801	2,7	171,55	S143	100LR	6	35000	18500
5,4	1864	1,7	177,53	S123	100LR	6	30000	11200
5,4	1841	2,4	175,41	S143	100LR	6	35000	18500
5,1	1935	1,5	280,10	S123	90S	4	30000	11200
4,9	2043	1,5	194,59	S123	100LR	6	30000	11200
4,8	2065	2,4	196,74	S143	100LR	6	35000	18500
4,7	2080	1,4	301,16	S123	90S	4	30000	11200
4,4	2263	1,4	215,60	S123	100LR	6	30000	11200
4,3	2337	2,1	222,57	S143	100LR	6	35000	18500
4,2	2375	1,2	343,93	S123	90S	4	30000	11200
4,0	2508	1,3	238,93	S123	100LR	6	30000	11200
4,0	2495	2,1	237,63	S143	100LR	6	35000	18500
3,7	2683	1,2	255,54	S123	100LR	6	30000	11200
3,5	2870	1,8	273,41	S143	100LR	6	35000	18500
3,4	2941	1,1	280,10	S123	100LR	6	30000	11200
3,2	3162	1,0	301,16	S123	100LR	6	30000	11200

1,50 kW

n2 [rpm]	M2 [Nm]	fs	i	Gear reducer	Size	Motor Pole	Fr2 D [N]	Fr2 C-L [N]
331,6	40	3,2	8,63	S052	90S	2	3211	3211
256,7	52	2,8	11,14	S052	90S	2	3447	3447
238,3	56	2,7	12,00	S052	90S	2	3520	3520
209,5	64	2,5	13,66	S052	90S	2	3650	3650
187,2	71	2,5	15,27	S052	90S	2	3747	3747
175,6	76	2,4	16,29	S052	90S	2	3812	3812
165,8	83	2,0	8,63	S052	90L	4	3857	3857

1,50 kW

n2 [rpm]	M2 [Nm]	fs	i	Gear reducer	Size	Motor Pole	Fr2 D [N]	Fr2 C-L [N]
160,3	86	3,9	8,92	S062	90L	4	7030	2812
153,5	86	2,1	18,63	S052	90S	2	3949	3949
149,8	92	3,9	9,55	S062	90L	4	7162	2865
148,3	89	3,7	19,29	S062	90S	2	7175	2870
146,3	91	3,8	19,55	S062	90S	2	7188	2875
145,0	92	2,0	19,73	S052	90S	2	3997	3997
136,0	98	2,0	21,04	S052	90S	2	4059	4059
134,3	103	3,5	10,65	S062	90L	4	7378	2951
132,8	100	2,0	21,53	S052	90S	2	4078	4078
128,4	107	1,8	11,14	S052	90L	4	4099	4099
123,4	108	3,3	23,18	S062	90S	2	7530	3012
122,1	113	3,5	11,71	S062	90L	4	7526	3010
120,4	110	3,2	23,75	S062	90S	2	7572	3029
119,2	116	1,7	12,00	S052	90L	4	4181	4181
118,8	112	1,7	24,07	S052	90S	2	4187	4187
117,5	118	2,9	8,00	S062	100L	6	7596	3038
113,8	117	3,1	25,14	S062	90S	2	7695	3078
113,5	117	1,9	25,20	S052	90S	2	4227	4227
110,9	120	1,8	25,79	S052	90S	2	4252	4252
109,5	126	3,3	13,06	S062	90L	4	7745	3098
109,0	128	1,4	8,63	S052	100L	6	4245	4245
107,0	128	3,3	13,36	S062	90L	4	7834	3134
105,4	132	2,6	8,92	S062	100L	6	7815	3126
104,7	131	1,6	13,66	S052	90L	4	4298	4298
103,4	128	2,8	27,66	S062	90S	2	7884	3154
102,8	129	1,7	27,81	S052	90S	2	4319	4319
98,4	141	2,7	9,55	S062	100L	6	7974	3189
95,4	139	1,6	30,00	S052	90S	2	4389	4389
95,4	139	2,7	30,00	S062	90S	2	8052	3221
93,6	147	1,6	15,27	S052	90L	4	4378	4378
89,7	154	3,0	15,94	S062	90L	4	8194	3277
88,5	156	2,9	16,16	S062	90L	4	8193	3277
88,3	157	2,4	10,65	S062	100L	6	8195	3278
87,9	152	1,5	32,55	S052	90S	2	4462	4462
87,8	157	1,5	16,29	S052	90L	4	4434	4434
86,7	154	1,5	33,00	S052	90S	2	4474	4474
85,2	153	3,0	33,57	S063	90S	2	8312	3325
84,4	165	1,2	11,14	S052	100L	6	4458	4458
84,3	158	2,6	33,93	S062	90S	2	8328	3331
83,9	159	1,4	34,09	S052	90S	2	4503	4503
80,3	173	2,3	11,71	S062	100L	6	8388	3355
78,4	166	1,6	36,50	S053	90S	2	4585	4585

1,50 kW

n2 [rpm]	M2 [Nm]	fs	i	Gear reducer	Size	Motor Pole	Fr2 D [N]	Fr2 C-L [N]
78,3	177	1,2	12,00	S052	100L	6	4527	4527
78,3	170	1,5	36,55	S052	90S	2	4565	4565
78,2	170	2,7	36,57	S062	90S	2	8470	3388
76,7	179	1,3	18,63	S052	90L	4	4562	4562
75,7	172	2,6	37,77	S063	90S	2	8560	3424
74,1	186	2,4	19,29	S062	90L	4	8553	3421
73,8	180	1,4	38,75	S052	90S	2	4614	4614
73,1	188	2,4	19,55	S062	90L	4	8566	3427
72,6	183	2,5	39,38	S062	90S	2	8623	3449
72,5	190	1,3	19,73	S052	90L	4	4591	4591
72,0	193	2,3	13,06	S062	100L	6	8587	3435
71,7	185	1,4	39,90	S052	90S	2	4638	4638
71,4	182	2,5	40,05	S063	90S	2	8683	3473
71,0	194	4,0	20,14	S082	90L	4	18000	5296
70,4	197	2,2	13,36	S062	100L	6	8632	3453
68,8	202	1,1	13,66	S052	100L	6	4618	4618
68,0	203	1,3	21,04	S052	90L	4	4655	4655
67,1	198	1,3	42,63	S052	90S	2	4691	4691
66,9	208	3,8	14,04	S082	100L	6	18000	5391
66,5	208	1,2	21,53	S052	90L	4	4662	4662
66,4	200	3,8	43,05	S082	90S	2	18000	5412
65,6	203	2,2	43,64	S062	90S	2	8827	3531
64,6	213	3,8	22,13	S082	90L	4	18000	5451
62,2	214	1,2	46,00	S052	90S	2	4746	4746
62,0	214	2,1	46,10	S062	90S	2	8947	3579
61,7	223	2,1	23,18	S062	90L	4	8951	3581
61,5	226	1,1	15,27	S052	100L	6	4697	4697
60,9	228	3,5	15,43	S082	100L	6	18000	5548
60,6	219	1,2	47,20	S052	90S	2	4772	4772
60,6	214	1,2	47,14	S053	90S	2	4798	4798
60,2	228	2,0	23,75	S062	90L	4	8972	3589
59,7	233	3,4	15,73	S082	100L	6	18000	5598
59,5	231	3,5	24,00	S082	90L	4	18000	5624
59,4	231	1,1	24,07	S052	90L	4	4739	4739
59,2	224	2,0	48,30	S062	90S	2	9057	3623
59,0	235	2,0	15,94	S062	100L	6	9005	3602
58,2	223	2,0	49,13	S063	90S	2	9121	3649
58,2	239	2,0	16,16	S062	100L	6	9011	3605
57,7	241	1,0	16,29	S052	100L	6	4739	4739
56,9	242	2,0	25,14	S062	90L	4	9070	3628
56,9	233	3,2	50,25	S082	90S	2	18000	5686
56,8	243	1,2	25,20	S052	90L	4	4777	4777

1,50 kW

n2 [rpm]	M2 [Nm]	fs	i	Gear reducer	Size	Motor Pole	Fr2 D [N]	Fr2 C-L [N]
55,5	248	1,2	25,79	S052	90L	4	4782	4782
54,9	251	3,2	26,05	S082	90L	4	18000	5765
54,7	243	1,1	52,25	S052	90S	2	4835	4835
54,4	256	3,2	17,29	S082	100L	6	18000	5743
53,4	249	1,8	53,53	S062	90S	2	9242	3697
52,7	252	3,0	54,27	S082	90S	2	18000	5820
52,4	262	3,5	27,29	S082	90L	4	18000	5846
52,0	255	1,8	55,00	S062	90S	2	9317	3727
51,9	256	3,8	55,14	S102	90S	2	22000	7220
51,8	251	1,8	55,29	S063	90S	2	9362	3745
51,7	266	1,8	27,66	S062	90L	4	9296	3719
51,4	267	1,1	27,81	S052	90L	4	4834	4834
50,4	275	0,9	18,63	S052	100L	6	4822	4822
49,8	276	3,3	28,67	S082	90L	4	18000	5934
49,5	263	1,0	57,79	S053	90S	2	4929	4929
49,4	281	2,9	19,03	S082	100L	6	18000	5911
48,7	267	1,7	58,72	S063	90S	2	9482	3793
48,7	285	1,7	19,29	S062	100L	6	9351	3740
48,3	285	3,2	29,60	S082	90L	4	18000	5953
48,1	289	1,7	19,55	S062	100L	6	9376	3750
47,7	289	1,0	30,00	S052	90L	4	4861	4861
47,7	289	1,7	30,00	S062	90L	4	9411	3764
46,7	298	2,7	20,14	S082	100L	6	18000	6012
46,1	288	2,6	61,98	S082	90S	2	18000	6039
45,0	306	3,3	31,78	S082	90L	4	18000	6081
43,9	313	0,9	32,55	S052	90L	4	4905	4905
43,4	299	1,5	65,85	S063	90S	2	9686	3875
43,3	318	0,9	33,00	S052	90L	4	4905	4905
42,6	316	1,9	33,57	S063	90L	4	9699	3880
42,5	327	2,6	22,13	S082	100L	6	18000	6183
42,4	313	1,4	67,47	S062	90S	2	9692	3877
42,4	307	2,5	67,52	S083	90S	2	18000	6202
42,2	327	1,6	33,93	S062	90L	4	9649	3860
42,2	315	3,8	67,84	S102	90S	2	22000	7676
42,0	310	1,5	68,25	S063	90S	2	9755	3902
41,9	328	0,9	34,09	S052	90L	4	4914	4914
41,0	336	3,0	34,91	S082	90L	4	18000	6253
40,5	342	1,4	23,18	S062	100L	6	9702	3881
40,2	342	3,0	35,50	S082	90L	4	18000	6324
39,6	351	1,4	23,75	S062	100L	6	9744	3898
39,2	344	1,0	36,50	S053	90L	4	4978	4978
39,2	355	2,4	24,00	S082	100L	6	18000	6333

1,50 kW

n2 [rpm]	M2 [Nm]	fs	i	Gear reducer	Size	Motor Pole	Fr2 D [N]	Fr2 C-L [N]
39,2	352	0,9	36,55	S052	90L	4	4937	4937
39,1	352	1,7	36,57	S062	90L	4	9769	3908
38,8	335	1,3	73,63	S063	90S	2	9904	3962
38,6	337	2,2	74,18	S083	90S	2	18000	6378
38,6	337	3,6	74,18	S103	90S	2	22000	7896
37,9	356	1,7	37,77	S063	90L	4	9873	3949
37,4	372	1,4	25,14	S062	100L	6	9822	3929
37,4	368	4,1	38,30	S102	90L	4	22000	8020
36,3	379	1,6	39,38	S062	90L	4	9894	3958
36,1	385	2,2	26,05	S082	100L	6	18000	6488
35,8	384	0,9	39,90	S052	90L	4	4953	4953
35,8	377	1,6	40,05	S063	90L	4	9985	3994
35,8	385	2,6	40,05	S082	90L	4	18000	6525
35,2	370	3,3	81,39	S103	90S	2	22000	8125
35,1	370	1,2	81,43	S063	90S	2	10000	4000
35,0	371	2,0	81,71	S083	90S	2	18000	6583
34,5	404	2,3	27,29	S082	100L	6	18000	6597
34,0	409	1,2	27,66	S062	100L	6	9976	3990
33,6	409	3,5	42,53	S102	90L	4	22000	8281
33,2	414	2,5	43,05	S082	90L	4	18000	6691
32,8	424	2,2	28,67	S082	100L	6	18000	6672
32,7	420	1,4	43,64	S062	90L	4	10000	4000
32,5	423	3,1	44,00	S102	90L	4	22000	8332
31,8	408	2,9	89,77	S103	90S	2	22000	8400
31,7	437	2,1	29,60	S082	100L	6	18000	6754
31,4	441	3,5	29,87	S102	100L	6	22000	8420
31,3	443	1,2	30,00	S062	100L	6	10000	4000
31,2	416	1,8	91,49	S083	90S	2	18000	6805
31,1	444	1,3	46,10	S062	90L	4	10000	4000
30,3	453	3,6	47,13	S102	90L	4	22000	8544
29,6	465	1,3	48,30	S062	90L	4	10000	4000
29,6	470	2,2	31,78	S082	100L	6	18000	6872
29,1	463	1,3	49,13	S063	90L	4	10000	4000
29,0	479	3,3	32,40	S102	100L	6	22000	8602
28,6	455	2,6	100,15	S103	90S	2	22000	8666
28,5	484	2,0	50,25	S082	90L	4	18000	6996
28,5	484	2,9	50,25	S102	90L	4	22000	8711
28,4	458	1,6	100,62	S083	90S	2	18000	6974
27,7	502	1,1	33,93	S062	100L	6	10000	4000
26,9	516	2,0	34,91	S082	100L	6	18000	7060
26,9	516	2,8	34,91	S102	100L	6	22000	8798
26,7	515	1,2	53,53	S062	90L	4	10000	4000

1,50 kW

n2 [rpm]	M2 [Nm]	fs	i	Gear reducer	Size	Motor Pole	Fr2 D [N]	Fr2 C-L [N]
26,5	525	2,0	35,50	S082	100L	6	18000	7093
26,4	522	1,9	54,27	S082	90L	4	18000	7122
26,0	529	1,1	55,00	S062	90L	4	10000	4000
25,9	531	2,5	55,14	S102	90L	4	22000	8958
25,9	503	2,4	110,55	S103	90S	2	22000	8920
25,9	521	1,2	55,29	S063	90L	4	10000	4000
25,7	540	1,2	36,57	S062	100L	6	10000	4000
24,5	566	2,8	38,30	S102	100L	6	22000	9000
24,4	533	1,4	117,17	S083	90S	2	18000	7200
24,3	553	1,1	58,72	S063	90L	4	10000	4000
24,1	571	2,8	59,40	S102	90L	4	22000	9000
23,9	582	1,1	39,38	S062	100L	6	10000	4000
23,6	551	2,2	121,29	S103	90S	2	22000	9000
23,5	592	1,8	40,05	S082	100L	6	18000	7200
23,2	560	4,0	123,33	S123	90S	2	30000	11200
23,1	596	1,6	61,98	S082	90L	4	18000	7200
22,2	585	1,3	128,73	S083	90S	2	18000	7200
22,2	585	2,1	128,73	S103	90S	2	22000	9000
22,1	628	2,3	42,53	S102	100L	6	22000	9000
22,0	591	3,8	130,04	S123	90S	2	30000	11200
21,8	636	1,6	43,05	S082	100L	6	18000	7200
21,7	620	1,0	65,85	S063	90L	4	10000	4000
21,5	645	1,0	43,64	S062	100L	6	10000	4000
21,4	608	3,7	133,78	S123	90S	2	30000	11200
21,3	650	2,1	44,00	S102	100L	6	22000	9000
21,2	649	0,9	67,47	S062	90L	4	10000	4000
21,2	636	1,6	67,52	S083	90L	4	18000	7200
21,0	652	2,4	67,84	S102	90L	4	22000	9000
21,0	660	3,8	44,63	S122	100L	6	30000	11200
21,0	643	0,9	68,25	S063	90L	4	10000	4000
20,9	620	1,2	136,34	S083	90S	2	18000	7200
20,2	642	1,9	141,24	S103	90S	2	22000	9000
19,9	697	2,4	47,13	S102	100L	6	22000	9000
19,3	699	1,4	74,18	S083	90L	4	18000	7200
19,3	699	2,3	74,18	S103	90L	4	22000	9000
19,2	725	3,5	49,04	S122	100L	6	30000	11200
18,9	688	3,3	151,43	S123	90S	2	30000	11200
18,7	742	1,4	50,25	S082	100L	6	18000	7200
18,7	742	2,0	50,25	S102	100L	6	22000	9000
18,0	722	1,0	158,76	S083	90S	2	18000	7200
17,5	770	1,3	81,71	S083	90L	4	18000	7200
17,5	767	2,1	81,39	S103	90L	4	22000	9000

1,50 kW

n2 [rpm]	M2 [Nm]	fs	i	Gear reducer	Size	Motor Pole	Fr2 D [N]	Fr2 C-L [N]
17,5	794	3,4	53,75	S122	100L	6	30000	11200
17,3	802	1,3	54,27	S082	100L	6	18000	7200
17,0	815	1,7	55,14	S102	100L	6	22000	9000
16,5	790	1,5	173,78	S103	90S	2	22000	9000
16,1	807	2,8	177,53	S123	90S	2	30000	11200
15,9	845	1,9	89,77	S103	90L	4	22000	9000
15,8	878	1,9	59,40	S102	100L	6	22000	9000
15,6	862	1,2	91,49	S083	90L	4	18000	7200
15,2	857	1,4	188,51	S103	90S	2	22000	9000
15,2	916	1,1	61,98	S082	100L	6	18000	7200
14,6	884	2,6	194,59	S123	90S	2	30000	11200
14,5	938	3,0	64,84	S123	100L	6	30000	11200
14,3	943	1,7	100,15	S103	90L	4	22000	9000
14,3	976	3,2	66,00	S122	100L	6	30000	11200
14,2	948	1,1	100,62	S083	90L	4	18000	7200
14,1	923	1,3	203,11	S103	90S	2	22000	9000
13,9	977	1,1	67,52	S083	100L	6	18000	7200
13,8	1002	1,7	67,84	S102	100L	6	22000	9000
13,3	980	2,3	215,60	S123	90S	2	30000	11200
13,2	1028	2,8	71,07	S123	100L	6	30000	11200
12,9	1041	1,5	110,55	S103	90L	4	22000	9000
12,8	1013	1,2	222,85	S103	90S	2	22000	9000
12,8	1022	1,2	224,76	S103	90S	2	22000	9000
12,7	1060	2,8	112,52	S123	90L	4	30000	11200
12,6	1073	1,0	74,18	S083	100L	6	18000	7200
12,6	1073	1,5	74,18	S103	100L	6	22000	9000
12,2	1103	0,9	117,17	S083	90L	4	18000	7200
12,0	1135	2,8	78,46	S123	100L	6	30000	11200
12,0	1086	2,1	238,93	S123	90S	2	30000	11200
11,8	1150	3,9	79,45	S143	100L	6	35000	18500
11,7	1143	1,4	121,29	S103	90L	4	22000	9000
11,6	1161	2,6	123,33	S123	90L	4	30000	11200
11,5	1178	1,4	81,39	S103	100L	6	22000	9000
11,2	1161	1,9	255,54	S123	90S	2	30000	11200
11,1	1212	1,3	128,73	S103	90L	4	22000	9000
11,0	1225	2,4	130,04	S123	90L	4	30000	11200
10,8	1263	2,5	87,27	S123	100L	6	30000	11200
10,7	1260	2,4	133,78	S123	90L	4	30000	11200
10,5	1299	1,3	89,77	S103	100L	6	22000	9000
10,2	1273	1,8	280,10	S123	90S	2	30000	11200
10,1	1330	1,2	141,24	S103	90L	4	22000	9000
9,5	1430	3,3	98,81	S143	100L	6	35000	18500

1,50 kW

n2 [rpm]	M2 [Nm]	fs	i	Gear reducer	Size	Motor Pole	Fr2 D [N]	Fr2 C-L [N]
9,5	1369	1,7	301,16	S123	90S	2	30000	11200
9,4	1449	1,1	100,15	S103	100L	6	22000	9000
9,4	1426	2,1	151,43	S123	90L	4	30000	11200
8,9	1533	2,0	105,91	S123	100L	6	30000	11200
8,5	1592	3,1	110,05	S143	100L	6	35000	18500
8,5	1600	1,0	110,55	S103	100L	6	22000	9000
8,4	1628	1,9	112,52	S123	100L	6	30000	11200
8,3	1563	1,4	343,93	S123	90S	2	30000	11200
8,3	1637	1,0	173,78	S103	90L	4	22000	9000
8,1	1672	1,8	177,53	S123	90L	4	30000	11200
7,8	1755	0,9	121,29	S103	100L	6	22000	9000
7,6	1775	0,9	188,51	S103	90L	4	22000	9000
7,6	1786	2,8	123,44	S143	100L	6	35000	18500
7,6	1785	1,7	123,33	S123	100L	6	30000	11200
7,4	1833	1,6	194,59	S123	90L	4	30000	11200
7,3	1862	0,9	128,73	S103	100L	6	22000	9000
7,2	1882	1,7	130,04	S123	100L	6	30000	11200
7,0	1936	1,6	133,78	S123	100L	6	30000	11200
6,8	2020	2,5	139,64	S143	100L	6	35000	18500
6,6	2031	1,4	215,60	S123	90L	4	30000	11200
6,3	2157	2,3	149,10	S143	100L	6	35000	18500
6,2	2192	1,4	151,43	S123	100L	6	30000	11200
6,0	2279	1,8	157,49	S143	100L	6	35000	18500
5,9	2250	1,3	238,93	S123	90L	4	30000	11200
5,6	2407	1,2	255,54	S123	90L	4	30000	11200
5,5	2482	2,0	171,55	S143	100L	6	35000	18500
5,4	2538	1,8	175,41	S143	100L	6	35000	18500
5,3	2569	1,2	177,53	S123	100L	6	30000	11200
5,1	2638	1,1	280,10	S123	90L	4	30000	11200
4,9	2816	1,1	194,59	S123	100L	6	30000	11200
4,8	2846	1,7	196,74	S143	100L	6	35000	18500
4,7	2836	1,0	301,16	S123	90L	4	30000	11200
4,3	3120	1,0	215,60	S123	100L	6	30000	11200
4,2	3220	1,5	222,57	S143	100L	6	35000	18500
4,2	3239	0,9	343,93	S123	90L	4	30000	11200
3,9	3438	1,5	237,63	S143	100L	6	35000	18500
3,9	3457	0,9	238,93	S123	100L	6	30000	11200
3,4	3956	1,3	273,41	S143	100L	6	35000	18500

2,20 kW

n2 [rpm]	M2 [Nm]	fs	i	Gear reducer	Size	Motor Pole	Fr2 D [N]	Fr2 C-L [N]
333,9	59	2,2	8,63	S052	90L	2	3106	3106
270,5	72	3,8	10,65	S062	90L	2	5881	2353
258,5	75	1,9	11,14	S052	90L	2	3310	3310
246,0	79	3,7	11,71	S062	90L	2	6050	2420
240,0	81	1,8	12,00	S052	90L	2	3369	3369
220,5	88	3,5	13,06	S062	90L	2	6232	2493
215,6	90	3,5	13,36	S062	90L	2	6270	2508
210,9	92	1,7	13,66	S052	90L	2	3471	3471
188,6	103	1,7	15,27	S052	90L	2	3558	3558
180,7	108	3,1	15,94	S062	90L	2	6557	2623
180,0	113	3,0	8,00	S062	100LA	4	6516	2606
178,1	109	3,1	16,16	S062	90L	2	6593	2637
176,8	110	1,6	16,29	S052	90L	2	3607	3607
166,9	121	1,4	8,63	S052	100LA	4	3631	3631
161,4	125	2,6	8,92	S062	100LA	4	6747	2699
154,6	126	1,4	18,63	S052	90L	2	3708	3708
150,9	134	2,7	9,55	S062	100LA	4	6861	2744
149,3	130	2,6	19,29	S062	90L	2	6896	2758
147,3	132	2,6	19,55	S062	90L	2	6920	2768
146,0	133	1,3	19,73	S052	90L	2	3749	3749
137,0	142	1,4	21,04	S052	90L	2	3794	3794
135,3	149	2,4	10,65	S062	100LA	4	6998	2799
133,8	146	1,3	21,53	S052	90L	2	3805	3805
130,8	156	3,7	7,34	S082	112M	6	15160	4332
130,2	150	4,0	22,13	S082	90L	2	15239	4354
129,3	156	1,2	11,14	S052	100LA	4	3788	3788
124,3	157	2,3	23,18	S062	90L	2	7200	2880
123,0	164	2,4	11,71	S062	100LA	4	7158	2863
121,3	161	2,2	23,75	S062	90L	2	7241	2897
120,0	168	1,2	12,00	S052	100LA	4	3835	3835
120,0	170	2,0	8,00	S062	112M	6	7211	2885
120,0	162	3,7	24,00	S082	90L	2	15592	4455
119,7	163	1,2	24,07	S052	90L	2	3880	3880
119,0	171	3,7	8,06	S082	112M	6	15756	4502
114,5	170	2,1	25,14	S062	90L	2	7339	2935
114,3	170	1,3	25,20	S052	90L	2	3909	3909
111,7	174	1,2	25,79	S052	90L	2	3923	3923
111,3	183	0,9	8,63	S052	112M	6	3896	3896
110,6	176	3,4	26,05	S082	90L	2	15988	4568
110,3	183	2,3	13,06	S062	100LA	4	7362	2945
107,8	188	2,3	13,36	S062	100LA	4	7377	2951
107,6	189	1,8	8,92	S062	112M	6	7391	2956

2,20 kW

n2 [rpm]	M2 [Nm]	fs	i	Gear reducer	Motor Size	Pole	Fr2 D [N]	Fr2 C-L [N]
105,5	185	3,6	27,29	S082	90L	2	16251	4643
105,4	192	1,1	13,66	S052	100LA	4	3923	3923
104,1	187	1,9	27,66	S062	90L	2	7500	3000
103,6	188	1,2	27,81	S052	90L	2	3969	3969
102,5	197	3,9	14,04	S082	100LA	4	16337	4668
100,6	203	1,9	9,55	S062	112M	6	7501	3000
100,4	194	3,5	28,67	S082	90L	2	16463	4704
97,3	200	3,4	29,60	S082	90L	2	16623	4749
96,5	211	3,2	9,94	S082	112M	6	16791	4797
96,0	203	1,1	30,00	S052	90L	2	4011	4011
96,0	203	1,8	30,00	S062	90L	2	7636	3054
94,3	214	1,1	15,27	S052	100LA	4	3977	3977
93,3	216	3,5	15,43	S082	100LA	4	16844	4813
91,5	220	3,5	15,73	S082	100LA	4	16941	4840
90,6	215	3,5	31,78	S082	90L	2	16984	4852
90,3	223	2,0	15,94	S062	100LA	4	7697	3079
90,2	226	1,7	10,65	S062	112M	6	7675	3070
89,1	227	2,0	16,16	S062	100LA	4	7730	3092
88,5	220	1,0	32,55	S052	90L	2	4056	4056
88,4	228	1,0	16,29	S052	100LA	4	4009	4009
87,3	223	1,0	33,00	S052	90L	2	4062	4062
85,8	222	2,0	33,57	S063	90L	2	7861	3144
84,9	229	1,8	33,93	S062	90L	2	7848	3139
83,3	243	3,1	17,29	S082	100LA	4	17469	4991
82,7	246	3,0	11,61	S082	112M	6	17588	5025
82,5	236	3,2	34,91	S082	90L	2	17508	5002
82,0	248	1,6	11,71	S062	112M	6	7823	3129
81,2	240	3,1	35,50	S082	90L	2	17597	5028
78,9	242	1,1	36,50	S053	90L	2	4132	4132
78,8	247	1,0	36,55	S052	90L	2	4103	4103
78,7	247	1,8	36,57	S062	90L	2	7968	3187
77,3	261	0,9	18,63	S052	100LA	4	4062	4062
76,2	250	1,8	37,77	S063	90L	2	8052	3221
75,7	267	2,9	19,03	S082	100LA	4	17898	5114
75,3	271	2,9	12,75	S082	112M	6	17917	5119
75,3	271	3,9	12,75	S102	112M	6	22000	6338
74,6	270	1,6	19,29	S062	100LA	4	8001	3200
73,6	274	1,7	19,55	S062	100LA	4	8021	3208
73,5	277	1,5	13,06	S062	112M	6	8031	3213
73,1	266	1,7	39,38	S062	90L	2	8082	3233
71,9	265	1,7	40,05	S063	90L	2	8144	3258
71,9	271	2,8	40,05	S082	90L	2	18000	5212

2,20 kW

n2 [rpm]	M2 [Nm]	fs	i	Gear reducer	Size	Motor Pole	Fr2 D [N]	Fr2 C-L [N]
71,8	284	1,5	13,36	S062	112M	6	8064	3225
71,5	282	2,7	20,14	S082	100LA	4	18000	5211
68,3	298	2,7	14,04	S082	112M	6	18000	5317
67,7	287	3,7	42,53	S102	90L	2	22000	6558
66,9	291	2,6	43,05	S082	90L	2	18000	5314
66,0	295	1,5	43,64	S062	90L	2	8226	3290
65,5	297	3,3	44,00	S102	90L	2	22000	6627
65,1	310	2,6	22,13	S082	100LA	4	18000	5325
62,5	312	1,4	46,10	S062	90L	2	8304	3322
62,2	327	2,5	15,43	S082	112M	6	18000	5465
62,2	327	4,0	15,43	S102	112M	6	22000	6786
62,1	325	1,4	23,18	S062	100LA	4	8240	3296
61,1	319	3,7	47,13	S102	90L	2	22000	6783
61,0	334	2,4	15,73	S082	112M	6	18000	5445
60,6	333	1,4	23,75	S062	100LA	4	8273	3309
60,3	338	1,4	15,94	S062	112M	6	8301	3320
60,0	337	2,4	24,00	S082	100LA	4	18000	5487
59,6	327	1,4	48,30	S062	90L	2	8379	3352
59,4	343	1,4	16,16	S062	112M	6	8278	3311
58,6	325	1,4	49,13	S063	90L	2	8437	3375
57,3	340	2,2	50,25	S082	90L	2	18000	5560
57,3	340	3,1	50,25	S102	90L	2	22000	6903
57,3	353	1,4	25,14	S062	100LA	4	8355	3342
55,7	365	3,7	17,21	S102	112M	6	22000	7016
55,5	367	2,2	17,29	S082	112M	6	18000	5649
55,3	365	2,2	26,05	S082	100LA	4	18000	5607
53,8	362	1,2	53,53	S062	90L	2	8506	3402
53,1	367	2,0	54,27	S082	90L	2	18000	5686
52,7	383	2,3	27,29	S082	100LA	4	18000	5706
52,4	372	1,2	55,00	S062	90L	2	8540	3416
52,2	373	2,6	55,14	S102	90L	2	22000	7101
52,1	366	1,2	55,29	S063	90L	2	8596	3438
52,0	388	1,2	27,66	S062	100LA	4	8477	3391
50,5	404	2,0	19,03	S082	112M	6	18000	5753
50,5	403	3,6	19,00	S102	112M	6	22000	7159
50,2	402	2,2	28,67	S082	100LA	4	18000	5764
49,8	409	1,2	19,29	S062	112M	6	8486	3394
49,1	415	1,2	19,55	S062	112M	6	8500	3400
49,0	389	1,2	58,72	S063	90L	2	8671	3468
48,6	415	2,2	29,60	S082	100LA	4	18000	5817
48,4	401	3,0	59,40	S102	90L	2	22000	7278
48,2	419	3,6	29,87	S102	100LA	4	22000	7234

2,20 kW

n2 [rpm]	M2 [Nm]	fs	i	Gear reducer	Motor Size	Pole	Fr2 D [N]	Fr2 C-L [N]
48,0	420	1,2	30,00	S062	100LA	4	8564	3426
47,7	427	1,9	20,14	S082	112M	6	18000	5900
46,4	419	1,8	61,98	S082	90L	2	18000	5919
46,1	442	3,3	20,83	S102	112M	6	22000	7360
45,3	445	2,3	31,78	S082	100LA	4	18000	5912
44,5	454	3,4	32,40	S102	100LA	4	22000	7414
43,7	436	1,0	65,85	S063	90L	2	8801	3520
43,4	470	1,8	22,13	S082	112M	6	18000	6058
43,4	470	3,1	22,13	S102	112M	6	22000	7566
42,7	447	1,7	67,52	S083	90L	2	18000	6062
42,5	459	2,6	67,84	S102	90L	2	22000	7575
42,4	476	1,2	33,93	S062	100LA	4	8654	3462
41,4	492	1,0	23,18	S062	112M	6	8679	3471
41,3	489	2,0	34,91	S082	100LA	4	18000	6118
41,3	489	2,8	34,91	S102	100LA	4	22000	7644
40,6	498	2,0	35,50	S082	100LA	4	18000	6135
40,4	504	1,0	23,75	S062	112M	6	8673	3469
40,1	510	1,7	24,00	S082	112M	6	18000	6196
39,5	515	3,1	24,28	S102	112M	6	22000	7777
39,4	512	1,2	36,57	S062	100LA	4	8729	3492
38,8	491	1,5	74,18	S083	90L	2	18000	6225
38,8	491	2,4	74,18	S103	90L	2	22000	7772
38,2	534	0,9	25,14	S062	112M	6	8711	3484
37,6	536	2,8	38,30	S102	100LA	4	22000	7857
36,9	553	1,5	26,05	S082	112M	6	18000	6337
36,6	552	1,1	39,38	S062	100LA	4	8770	3508
36,5	559	2,8	26,33	S102	112M	6	22000	7892
36,0	561	1,8	40,05	S082	100LA	4	18000	6355
35,4	539	2,2	81,39	S103	90L	2	22000	7989
35,2	579	1,7	27,29	S082	112M	6	18000	6418
35,2	541	1,4	81,71	S083	90L	2	18000	6395
33,9	596	2,4	42,53	S102	100LA	4	22000	8070
33,5	604	1,6	43,05	S082	100LA	4	18000	6481
33,4	608	1,5	28,67	S082	112M	6	18000	6505
33,0	611	1,0	43,64	S062	100LA	4	8819	3528
32,7	617	2,1	44,00	S102	100LA	4	22000	8167
32,4	628	1,5	29,60	S082	112M	6	18000	6505
32,3	626	3,8	44,63	S122	100LA	4	30000	11200
32,1	634	2,5	29,87	S102	112M	6	22000	8189
32,1	594	2,0	89,77	S103	90L	2	22000	8224
31,5	606	1,2	91,49	S083	90L	2	18000	6609
30,5	660	2,4	47,13	S102	100LA	4	22000	8332

2,20 kW

n2 [rpm]	M2 [Nm]	fs	i	Gear reducer	Motor Size	Pole	Fr2 D [N]	Fr2 C-L [N]
30,2	674	1,5	31,78	S082	112M	6	18000	6686
29,6	688	2,3	32,40	S102	112M	6	22000	8385
29,4	687	3,4	49,04	S122	100LA	4	30000	11200
28,8	663	1,8	100,15	S103	90L	2	22000	8491
28,7	704	1,4	50,25	S082	100LA	4	18000	6755
28,7	704	2,0	50,25	S102	100LA	4	22000	8506
28,6	666	1,1	100,62	S083	90L	2	18000	6781
27,5	741	1,4	34,91	S082	112M	6	18000	6853
27,5	741	2,0	34,91	S102	112M	6	22000	8645
27,0	754	1,4	35,50	S082	112M	6	18000	6883
26,8	753	3,5	53,75	S122	100LA	4	30000	11200
26,5	760	1,3	54,27	S082	100LA	4	18000	6842
26,1	732	1,6	110,55	S103	90L	2	22000	8738
26,1	773	1,7	55,14	S102	100LA	4	22000	8718
25,6	745	3,0	112,52	S123	90L	2	30000	11200
25,1	813	1,9	38,30	S102	112M	6	22000	8797
24,3	832	1,9	59,40	S102	100LA	4	22000	8852
24,0	850	1,2	40,05	S082	112M	6	18000	7041
23,7	803	1,5	121,29	S103	90L	2	22000	8974
23,4	816	2,7	123,33	S123	90L	2	30000	11200
23,3	872	3,6	41,07	S122	112M	6	30000	11200
23,2	868	1,2	61,98	S082	100LA	4	18000	7105
22,6	902	1,6	42,53	S102	112M	6	22000	9000
22,4	852	1,4	128,73	S103	90L	2	22000	9000
22,3	914	1,1	43,05	S082	112M	6	18000	7171
22,2	889	3,0	64,84	S123	100LA	4	30000	11200
22,1	861	2,6	130,04	S123	90L	2	30000	11200
22,0	925	3,4	43,60	S122	112M	6	30000	11200
21,8	934	1,5	44,00	S102	112M	6	22000	9000
21,8	925	3,3	66,00	S122	100LA	4	30000	11200
21,5	885	2,5	133,78	S123	90L	2	30000	11200
21,5	947	2,7	44,63	S122	112M	6	30000	11200
21,3	927	1,1	67,52	S083	100LA	4	18000	7200
21,2	951	1,7	67,84	S102	100LA	4	22000	9000
20,4	1000	1,7	47,13	S102	112M	6	22000	9000
20,4	935	1,3	141,24	S103	90L	2	22000	9000
20,2	975	2,8	71,07	S123	100LA	4	30000	11200
19,6	1041	2,4	49,04	S122	112M	6	30000	11200
19,4	1018	1,0	74,18	S083	100LA	4	18000	7200
19,4	1018	1,6	74,18	S103	100LA	4	22000	9000
19,1	1067	1,0	50,25	S082	112M	6	18000	7200
19,1	1067	1,3	50,25	S102	112M	6	22000	9000

2,20 kW

n2 [rpm]	M2 [Nm]	fs	i	Gear reducer	Motor Size	Pole	Fr2 D [N]	Fr2 C-L [N]
19,0	1002	2,2	151,43	S123	90L	2	30000	11200
18,3	1077	2,8	78,46	S123	100LA	4	30000	11200
18,1	1090	3,9	79,45	S143	100LA	4	35000	18500
17,9	1141	2,4	53,75	S122	112M	6	30000	11200
17,7	1152	0,9	54,27	S082	112M	6	18000	7200
17,7	1120	0,9	81,71	S083	100LA	4	18000	7200
17,7	1116	1,5	81,39	S103	100LA	4	22000	9000
17,4	1170	1,1	55,14	S102	112M	6	22000	9000
16,6	1150	1,0	173,78	S103	90L	2	22000	9000
16,5	1197	2,5	87,27	S123	100LA	4	30000	11200
16,2	1260	1,3	59,40	S102	112M	6	22000	9000
16,2	1175	1,9	177,53	S123	90L	2	30000	11200
16,0	1231	1,3	89,77	S103	100LA	4	22000	9000
14,8	1288	1,7	194,59	S123	90L	2	30000	11200
14,8	1344	3,7	64,68	S143	112M	6	35000	18500
14,8	1348	2,1	64,84	S123	112M	6	30000	11200
14,6	1356	3,3	98,81	S143	100LA	4	35000	18500
14,5	1401	2,2	66,00	S122	112M	6	30000	11200
14,4	1374	1,2	100,15	S103	100LA	4	22000	9000
14,2	1440	1,2	67,84	S102	112M	6	22000	9000
13,9	1435	3,6	69,06	S143	112M	6	35000	18500
13,6	1453	2,1	105,91	S123	100LA	4	30000	11200
13,5	1477	1,9	71,07	S123	112M	6	30000	11200
13,4	1427	1,6	215,60	S123	90L	2	30000	11200
13,1	1510	3,1	110,05	S143	100LA	4	35000	18500
13,0	1516	1,0	110,55	S103	100LA	4	22000	9000
12,9	1541	1,1	74,18	S103	112M	6	22000	9000
12,8	1543	1,9	112,52	S123	100LA	4	30000	11200
12,3	1630	2,0	78,46	S123	112M	6	30000	11200
12,1	1581	1,4	238,93	S123	90L	2	30000	11200
12,1	1651	2,7	79,45	S143	112M	6	35000	18500
11,9	1664	1,0	121,29	S103	100LA	4	22000	9000
11,8	1691	1,0	81,39	S103	112M	6	22000	9000
11,7	1691	1,7	123,33	S123	100LA	4	30000	11200
11,6	1693	2,8	123,44	S143	100LA	4	35000	18500
11,3	1691	1,3	255,54	S123	90L	2	30000	11200
11,1	1765	0,9	128,73	S103	100LA	4	22000	9000
11,1	1784	1,7	130,04	S123	100LA	4	30000	11200
11,0	1814	1,8	87,27	S123	112M	6	30000	11200
10,8	1835	1,6	133,78	S123	100LA	4	30000	11200
10,7	1865	0,9	89,77	S103	112M	6	22000	9000
10,3	1854	1,2	280,10	S123	90L	2	30000	11200

2,20 kW

n2 [rpm]	M2 [Nm]	fs	i	Gear reducer	Motor Size	Motor Pole	Fr2 D [N]	Fr2 C-L [N]
10,3	1916	2,5	139,64	S143	100LA	4	35000	18500
9,7	2053	2,3	98,81	S143	112M	6	35000	18500
9,6	2045	2,3	149,10	S143	100LA	4	35000	18500
9,6	1993	1,1	301,16	S123	90L	2	30000	11200
9,5	2077	1,4	151,43	S123	100LA	4	30000	11200
9,1	2201	1,4	105,91	S123	112M	6	30000	11200
9,1	2160	1,8	157,49	S143	100LA	4	35000	18500
8,7	2287	2,2	110,05	S143	112M	6	35000	18500
8,5	2338	1,3	112,52	S123	112M	6	30000	11200
8,4	2353	2,0	171,55	S143	100LA	4	35000	18500
8,2	2406	1,7	175,41	S143	100LA	4	35000	18500
8,1	2435	1,2	177,53	S123	100LA	4	30000	11200
7,7	2562	1,2	123,33	S123	112M	6	30000	11200
7,7	2565	2,0	123,44	S143	112M	6	35000	18500
7,4	2702	1,2	130,04	S123	112M	6	30000	11200
7,4	2669	1,1	194,59	S123	100LA	4	30000	11200
7,4	2698	1,7	196,74	S143	100LA	4	35000	18500
7,2	2780	1,1	133,78	S123	112M	6	30000	11200
6,9	2902	1,8	139,64	S143	112M	6	35000	18500
6,7	2957	1,0	215,60	S123	100LA	4	30000	11200
6,5	3053	1,6	222,57	S143	100LA	4	35000	18500
6,4	3098	1,7	149,10	S143	112M	6	35000	18500
6,3	3147	1,0	151,43	S123	112M	6	30000	11200
6,1	3273	1,2	157,49	S143	112M	6	35000	18500
6,0	3277	0,9	238,93	S123	100LA	4	30000	11200
6,0	3259	1,5	237,63	S143	100LA	4	35000	18500
5,6	3564	1,3	171,55	S143	112M	6	35000	18500
5,5	3645	1,2	175,41	S143	112M	6	35000	18500
5,3	3750	1,3	273,41	S143	100LA	4	35000	18500
4,9	4088	1,2	196,74	S143	112M	6	35000	18500
4,3	4625	1,1	222,57	S143	112M	6	35000	18500
4,0	4938	1,0	237,63	S143	112M	6	35000	18500

3,00 kW

n2 [rpm]	M2 [Nm]	fs	i	Gear reducer	Motor Size	Motor Pole	Fr2 D [N]	Fr2 C-L [N]
362,6	73	3,3	8,00	S062	100L	2	5305	2122
336,3	79	1,6	8,63	S052	100L	2	2979	2979
325,1	82	3,0	8,92	S062	100L	2	5462	2185
303,8	87	3,1	9,55	S062	100L	2	5561	2224
272,4	97	2,8	10,65	S062	100L	2	5705	2282
260,3	102	1,4	11,14	S052	100L	2	3141	3141

3,00 kW

n2 [rpm]	M2 [Nm]	fs	i	Gear reducer	Motor Size	Pole	Fr2 D [N]	Fr2 C-L [N]
247,7	107	2,7	11,71	S062	100L	2	5846	2338
241,7	110	1,4	12,00	S052	100L	2	3188	3188
222,1	120	2,6	13,06	S062	100L	2	6006	2403
217,1	123	2,6	13,36	S062	100L	2	6055	2422
212,4	125	1,3	13,66	S052	100L	2	3267	3267
197,6	139	4,0	7,34	S082	112MS	4	13221	3777
189,9	140	1,3	15,27	S052	100L	2	3331	3331
184,4	144	4,0	15,73	S082	100L	2	13563	3875
182,0	146	2,3	15,94	S062	100L	2	6299	2520
181,3	152	2,2	8,00	S062	112MS	4	6271	2508
179,8	153	3,9	8,06	S082	112MS	4	13607	3888
179,4	148	2,3	16,16	S062	100L	2	6320	2528
178,0	149	1,2	16,29	S052	100L	2	3371	3371
168,1	164	1,0	8,63	S052	112MS	4	3362	3362
167,6	158	3,6	17,29	S082	100L	2	13963	3989
162,5	169	2,0	8,92	S062	112MS	4	6425	2570
155,6	171	1,1	18,63	S052	100L	2	3433	3433
152,4	174	3,3	19,03	S082	100L	2	14374	4107
151,9	181	2,0	9,55	S062	112MS	4	6519	2608
150,4	177	1,9	19,29	S062	100L	2	6574	2630
148,3	179	1,9	19,55	S062	100L	2	6608	2643
145,8	189	3,4	9,94	S082	112MS	4	14500	4143
144,0	184	3,1	20,14	S082	100L	2	14623	4178
137,9	193	1,0	21,04	S052	100L	2	3486	3486
136,2	202	1,8	10,65	S062	112MS	4	6668	2667
132,2	210	2,7	7,34	S082	132S	6	14928	4265
131,1	203	2,9	22,13	S082	100L	2	15043	4298
125,1	212	1,7	23,18	S062	100L	2	6829	2732
124,9	220	3,2	11,61	S082	112MS	4	15188	4339
123,8	222	1,8	11,71	S062	112MS	4	6794	2718
122,1	218	1,6	23,75	S062	100L	2	6876	2750
120,8	220	2,7	24,00	S082	100L	2	15366	4390
120,3	231	2,7	8,06	S082	132S	6	15352	4386
120,3	231	3,9	8,06	S102	132S	6	19006	5430
115,3	231	1,5	25,14	S062	100L	2	6951	2781
113,7	242	3,1	12,75	S082	112MS	4	15618	4462
111,4	239	2,5	26,05	S082	100L	2	15794	4512
111,0	248	1,7	13,06	S062	112MS	4	6932	2773
109,6	253	3,7	8,85	S102	132S	6	19620	5606
108,6	253	1,7	13,36	S062	112MS	4	6960	2784
106,3	250	2,7	27,29	S082	100L	2	15963	4561
104,9	253	1,4	27,66	S062	100L	2	7073	2829

3,00 kW

n2 [rpm]	M2 [Nm]	fs	i	Gear reducer	Motor Size	Pole	Fr2 D [N]	Fr2 C-L [N]
103,2	266	2,9	14,04	S082	112MS	4	16070	4591
101,1	262	2,5	28,67	S082	100L	2	16248	4642
98,0	271	2,5	29,60	S082	100L	2	16400	4686
97,5	285	2,4	9,94	S082	132S	6	16379	4680
96,7	275	1,4	30,00	S062	100L	2	7160	2864
94,0	293	2,6	15,43	S082	112MS	4	16517	4719
92,2	298	2,6	15,73	S082	112MS	4	16609	4745
91,3	291	2,6	31,78	S082	100L	2	16693	4770
91,0	302	1,5	15,94	S062	112MS	4	7164	2866
89,7	307	1,5	16,16	S062	112MS	4	7179	2872
89,5	297	3,8	32,40	S102	100L	2	20846	5956
89,1	312	3,2	10,88	S102	132S	6	20837	5954
85,5	311	1,3	33,93	S062	100L	2	7312	2925
84,2	326	4,0	17,21	S102	112MS	4	21205	6059
83,8	328	2,3	17,29	S082	112MS	4	17072	4878
83,6	333	2,2	11,61	S082	132S	6	17128	4894
83,1	320	2,3	34,91	S082	100L	2	17207	4916
83,1	320	3,3	34,91	S102	100L	2	21392	6112
81,7	325	2,3	35,50	S082	100L	2	17239	4925
79,3	335	1,3	36,57	S062	100L	2	7380	2952
76,3	360	3,9	19,00	S102	112MS	4	21848	6242
76,2	361	2,1	19,03	S082	112MS	4	17545	5013
76,1	365	2,1	12,75	S082	132S	6	17593	5027
76,1	365	2,8	12,75	S102	132S	6	21927	6265
75,7	351	3,2	38,30	S102	100L	2	21933	6267
75,2	366	1,2	19,29	S062	112MS	4	7351	2940
74,2	371	1,2	19,55	S062	112MS	4	7363	2945
73,7	360	1,2	39,38	S062	100L	2	7461	2985
72,4	367	2,0	40,05	S082	100L	2	17845	5099
72,0	382	2,0	20,14	S082	112MS	4	17830	5094
69,6	395	3,5	20,83	S102	112MS	4	22000	6417
69,3	401	3,1	13,99	S102	132S	6	22000	6422
69,1	402	2,0	14,04	S082	132S	6	18000	5151
68,2	389	2,7	42,53	S102	100L	2	22000	6467
67,4	394	1,9	43,05	S082	100L	2	18000	5204
66,5	400	1,1	43,64	S062	100L	2	7549	3019
65,9	403	2,4	44,00	S102	100L	2	22000	6534
65,5	420	1,9	22,13	S082	112MS	4	18000	5231
65,5	420	3,3	22,13	S102	112MS	4	22000	6534
62,9	442	1,8	15,43	S082	132S	6	18000	5288
62,9	442	3,0	15,43	S102	132S	6	22000	6612
62,6	440	1,1	23,18	S062	112MS	4	7488	2995

3,00 kW

n2 [rpm]	M2 [Nm]	fs	i	Gear reducer	Size	Motor Pole	Fr2 D [N]	Fr2 C-L [N]
61,6	450	1,8	15,73	S082	132S	6	18000	5331
61,5	432	2,8	47,13	S102	100L	2	22000	6690
61,1	450	1,0	23,75	S062	112MS	4	7502	3001
60,4	455	1,8	24,00	S082	112MS	4	18000	5351
60,0	442	1,0	48,30	S062	100L	2	7620	3048
59,7	460	3,3	24,28	S102	112MS	4	22000	6716
59,1	449	4,0	49,04	S122	100L	2	30000	9674
57,7	477	1,0	25,14	S062	112MS	4	7531	3013
57,7	460	1,6	50,25	S082	100L	2	18000	5450
57,7	460	2,3	50,25	S102	100L	2	22000	6818
56,4	493	2,8	17,21	S102	132S	6	22000	6829
56,1	495	1,6	17,29	S082	132S	6	18000	5456
55,7	494	1,6	26,05	S082	112MS	4	18000	5472
55,1	499	3,0	26,33	S102	112MS	4	22000	6879
54,0	492	4,0	53,75	S122	100L	2	30000	9909
53,4	497	1,5	54,27	S082	100L	2	18000	5550
53,1	518	1,7	27,29	S082	112MS	4	18000	5542
52,6	505	1,9	55,14	S102	100L	2	22000	6986
52,4	525	0,9	27,66	S062	112MS	4	7566	3027
51,0	545	1,5	19,03	S082	132S	6	18000	5615
51,0	544	2,7	19,00	S102	132S	6	22000	7051
50,6	544	1,7	28,67	S082	112MS	4	18000	5617
49,0	561	1,6	29,60	S082	112MS	4	18000	5665
48,8	544	2,2	59,40	S102	100L	2	22000	7140
48,5	567	2,6	29,87	S102	112MS	4	22000	7137
48,2	577	1,4	20,14	S082	132S	6	18000	5685
46,8	567	1,3	61,98	S082	100L	2	18000	5770
46,6	597	2,4	20,83	S102	132S	6	22000	7241
45,6	603	1,7	31,78	S082	112MS	4	18000	5773
44,8	615	2,4	32,40	S102	112MS	4	22000	7307
44,7	581	3,5	64,84	S123	100L	2	30000	10480
43,9	604	3,7	66,00	S122	100L	2	30000	10520
43,8	634	1,3	22,13	S082	132S	6	18000	5828
43,8	634	2,3	22,13	S102	132S	6	22000	7346
43,6	637	3,9	22,24	S142	132S	6	35000	18500
42,9	605	1,2	67,52	S083	100L	2	18000	5899
42,7	621	1,9	67,84	S102	100L	2	22000	7421
41,5	662	1,5	34,91	S082	112MS	4	18000	5917
41,5	662	2,1	34,91	S102	112MS	4	22000	7466
40,8	637	3,1	71,07	S123	100L	2	30000	10793
40,8	673	1,5	35,50	S082	112MS	4	18000	5943
40,4	687	1,2	24,00	S082	132S	6	18000	5952

5.1 S GEARED MOTORS (50Hz)

3,00 kW

n2 [rpm]	M2 [Nm]	fs	i	Gear reducer	Size	Motor Pole	Fr2 D [N]	Fr2 C-L [N]
40,0	695	2,3	24,28	S102	132S	6	22000	7543
39,1	665	1,1	74,18	S083	100L	2	18000	6063
39,1	665	1,8	74,18	S103	100L	2	22000	7647
38,4	723	3,0	25,26	S142	132S	6	35000	18500
37,9	727	2,1	38,30	S102	112MS	4	22000	7665
37,3	746	1,1	26,05	S082	132S	6	18000	6094
37,0	703	3,2	78,46	S123	100L	2	30000	11069
36,9	754	2,1	26,33	S102	132S	6	22000	7742
36,2	760	1,3	40,05	S082	112MS	4	18000	6129
35,7	729	1,6	81,39	S103	100L	2	22000	7852
35,6	782	1,2	27,29	S082	132S	6	18000	6165
35,5	732	1,0	81,71	S083	100L	2	18000	6216
35,3	779	3,9	41,07	S122	112MS	4	30000	11167
34,3	812	3,0	28,33	S142	132S	6	35000	18500
34,1	807	1,7	42,53	S102	112MS	4	22000	7894
34,0	819	3,8	28,60	S122	132S	6	30000	11200
33,8	821	1,1	28,67	S082	132S	6	18000	6242
33,7	817	1,2	43,05	S082	112MS	4	18000	6240
33,3	827	3,6	43,60	S122	112MS	4	30000	11200
33,2	782	2,9	87,27	S123	100L	2	30000	11200
33,0	835	1,6	44,00	S102	112MS	4	22000	7969
32,7	848	1,1	29,60	S082	132S	6	18000	6291
32,5	847	2,8	44,63	S122	112MS	4	30000	11200
32,4	855	1,8	29,87	S102	132S	6	22000	8018
32,3	805	1,5	89,77	S103	100L	2	22000	8072
31,8	874	3,6	30,51	S122	132S	6	30000	11200
30,8	894	1,8	47,13	S102	112MS	4	22000	8122
30,5	910	1,2	31,78	S082	132S	6	18000	6384
30,3	918	3,1	32,05	S142	132S	6	35000	18500
29,9	928	1,7	32,40	S102	132S	6	22000	8200
29,6	938	3,3	32,76	S122	132S	6	30000	11200
29,6	930	2,6	49,04	S122	112MS	4	30000	11200
29,0	898	1,3	100,15	S103	100L	2	22000	8321
29,0	958	3,3	33,44	S122	132S	6	30000	11200
28,9	953	1,0	50,25	S082	112MS	4	18000	6479
28,9	953	1,5	50,25	S102	112MS	4	22000	8266
28,3	980	3,1	34,22	S142	132S	6	35000	18500
27,8	1000	1,1	34,91	S082	132S	6	18000	6527
27,8	1000	1,5	34,91	S102	132S	6	22000	8344
27,6	1009	3,1	35,20	S122	132S	6	30000	11200
27,4	949	2,3	105,91	S123	100L	2	30000	11200
27,0	1020	2,6	53,75	S122	112MS	4	30000	11200

3,00 kW

n2 [rpm]	M2 [Nm]	fs	i	Gear reducer	Motor Size	Pole	Fr2 D [N]	Fr2 C-L [N]
26,7	1029	1,0	54,27	S082	112MS	4	18000	6597
26,3	1046	1,2	55,14	S102	112MS	4	22000	8476
26,2	991	1,2	110,55	S103	100L	2	22000	8525
25,8	1008	2,2	112,52	S123	100L	2	30000	11200
25,3	1097	1,4	38,30	S102	132S	6	22000	8554
24,4	1127	1,4	59,40	S102	112MS	4	22000	8647
23,9	1087	1,1	121,29	S103	100L	2	22000	8741
23,6	1176	2,7	41,07	S122	132S	6	30000	11200
23,5	1105	2,0	123,33	S123	100L	2	30000	11200
22,8	1218	1,2	42,53	S102	132S	6	22000	8817
22,5	1154	1,0	128,73	S103	100L	2	22000	8881
22,4	1204	2,2	64,84	S123	112MS	4	30000	11200
22,4	1201	4,0	64,68	S143	112MS	4	35000	18500
22,3	1166	1,9	130,04	S123	100L	2	30000	11200
22,2	1249	2,5	43,60	S122	132S	6	30000	11200
22,0	1252	2,4	66,00	S122	112MS	4	30000	11200
21,7	1278	2,0	44,63	S122	132S	6	30000	11200
21,7	1199	1,9	133,78	S123	100L	2	30000	11200
21,4	1287	1,2	67,84	S102	112MS	4	22000	8953
21,2	1284	3,2	45,77	S143	132S	6	35000	18500
21,0	1283	3,8	69,06	S143	112MS	4	35000	18500
20,6	1350	1,2	47,13	S102	132S	6	22000	9000
20,4	1320	2,0	71,07	S123	112MS	4	30000	11200
19,8	1404	1,8	49,04	S122	132S	6	30000	11200
19,5	1378	1,2	74,18	S103	112MS	4	22000	9000
19,2	1357	1,7	151,43	S123	100L	2	30000	11200
19,0	1429	3,2	50,97	S143	132S	6	35000	18500
18,5	1457	2,1	78,46	S123	112MS	4	30000	11200
18,2	1476	2,9	79,45	S143	112MS	4	35000	18500
18,0	1539	1,8	53,75	S122	132S	6	30000	11200
17,8	1512	1,1	81,39	S103	112MS	4	22000	9000
17,0	1603	3,1	57,17	S143	132S	6	35000	18500
16,6	1621	1,9	87,27	S123	112MS	4	30000	11200
16,4	1591	1,4	177,53	S123	100L	2	30000	11200
16,2	1667	1,0	89,77	S103	112MS	4	22000	9000
15,0	1818	1,5	64,84	S123	132S	6	30000	11200
15,0	1814	2,7	64,68	S143	132S	6	35000	18500
14,9	1744	1,3	194,59	S123	100L	2	30000	11200
14,7	1835	2,4	98,81	S143	112MS	4	35000	18500
14,7	1890	1,6	66,00	S122	132S	6	30000	11200
14,0	1937	2,6	69,06	S143	132S	6	35000	18500
13,7	1967	1,5	105,91	S123	112MS	4	30000	11200

3,00 kW

n2 [rpm]	M2 [Nm]	fs	i	Gear reducer	Motor Size	Pole	Fr2 D [N]	Fr2 C-L [N]
13,6	1993	1,4	71,07	S123	132S	6	30000	11200
13,5	1932	1,2	215,60	S123	100L	2	30000	11200
13,2	2044	2,3	110,05	S143	112MS	4	35000	18500
13,2	2065	4,0	73,63	S153	132S	6	40000	19400
12,9	2090	1,4	112,52	S123	112MS	4	30000	11200
12,3	2200	1,4	78,46	S123	132S	6	30000	11200
12,2	2228	2,0	79,45	S143	132S	6	35000	18500
12,1	2142	1,0	238,93	S123	100L	2	30000	11200
11,8	2291	1,3	123,33	S123	112MS	4	30000	11200
11,7	2293	2,1	123,44	S143	112MS	4	35000	18500
11,2	2415	1,2	130,04	S123	112MS	4	30000	11200
11,1	2448	1,3	87,27	S123	132S	6	30000	11200
11,1	2445	3,0	87,16	S153	132S	6	40000	19400
10,8	2485	1,2	133,78	S123	112MS	4	30000	11200
10,4	2594	1,9	139,64	S143	112MS	4	35000	18500
10,0	2728	3,1	97,27	S153	132S	6	40000	19400
9,8	2771	1,7	98,81	S143	132S	6	35000	18500
9,7	2769	1,7	149,10	S143	112MS	4	35000	18500
9,6	2813	1,1	151,43	S123	112MS	4	30000	11200
9,2	2925	1,3	157,49	S143	112MS	4	35000	18500
9,2	2970	1,0	105,91	S123	132S	6	30000	11200
8,8	3086	1,6	110,05	S143	132S	6	35000	18500
8,7	3131	3,0	111,67	S153	132S	6	40000	19400
8,6	3155	1,0	112,52	S123	132S	6	30000	11200
8,5	3186	1,5	171,55	S143	112MS	4	35000	18500
8,3	3258	1,3	175,41	S143	112MS	4	35000	18500
8,2	3297	0,9	177,53	S123	112MS	4	30000	11200
7,9	3458	0,9	123,33	S123	132S	6	30000	11200
7,9	3462	1,4	123,44	S143	132S	6	35000	18500
7,9	3437	2,9	122,57	S153	132S	6	40000	19400
7,4	3654	1,3	196,74	S143	112MS	4	35000	18500
7,0	3904	2,5	139,21	S153	132S	6	40000	19400
7,0	3916	1,3	139,64	S143	132S	6	35000	18500
6,5	4181	1,2	149,10	S143	132S	6	35000	18500
6,5	4134	1,1	222,57	S143	112MS	4	35000	18500
6,3	4319	1,7	154,02	S153	132S	6	40000	19400
6,1	4414	1,1	237,63	S143	112MS	4	35000	18500
6,1	4487	1,9	160,02	S153	132S	6	40000	19400
5,7	4811	1,0	171,55	S143	132S	6	35000	18500
5,5	4958	1,7	176,81	S153	132S	6	40000	19400
5,3	5078	0,9	273,41	S143	112MS	4	35000	18500
5,0	5442	1,7	194,06	S153	132S	6	40000	19400

5.1 S GEARED MOTORS (50Hz)

3,00 kW

n2 [rpm]	M2 [Nm]	fs	i	Gear reducer	Size	Motor Pole	Fr2 D [N]	Fr2 C-L [N]
4,4	6181	1,6	220,42	S153	132S	6	40000	19400
3,8	7105	1,2	253,36	S153	132S	6	40000	19400

4,00 kW

n2 [rpm]	M2 [Nm]	fs	i	Gear reducer	Size	Motor Pole	Fr2 D [N]	Fr2 C-L [N]
366,3	97	2,6	8,00	S062	112M	2	5122	2049
339,7	104	1,2	8,63	S052	112M	2	2814	2814
328,4	108	2,3	8,92	S062	112M	2	5262	2105
307,0	115	2,3	9,55	S062	112M	2	5348	2139
275,2	129	2,1	10,65	S062	112M	2	5486	2195
263,0	135	1,1	11,14	S052	112M	2	2939	2939
252,5	141	3,7	11,61	S082	112M	2	12193	3484
250,3	142	2,0	11,71	S062	112M	2	5619	2248
244,2	145	1,0	12,00	S052	112M	2	2971	2971
229,9	154	3,6	12,75	S082	112M	2	12546	3585
224,4	158	2,0	13,06	S062	112M	2	5741	2297
219,3	161	1,9	13,36	S062	112M	2	5781	2313
208,6	170	3,4	14,04	S082	112M	2	12877	3679
197,6	186	3,0	7,34	S082	112M	4	13068	3734
189,9	186	3,1	15,43	S082	112M	2	13286	3796
186,3	190	3,0	15,73	S082	112M	2	13362	3818
183,9	192	1,7	15,94	S062	112M	2	5991	2396
181,3	195	1,7	16,16	S062	112M	2	5995	2398
181,2	203	1,6	8,00	S062	112M	4	5958	2383
179,8	204	2,9	8,06	S082	112M	4	13439	3840
169,4	209	2,8	17,29	S082	112M	2	13704	3915
163,9	223	4,0	8,85	S102	112M	4	17159	4903
162,5	226	1,5	8,92	S062	112M	4	6068	2427
154,0	230	2,5	19,03	S082	112M	2	14096	4027
151,9	241	1,5	9,55	S062	112M	4	6144	2458
151,9	233	1,4	19,29	S062	112M	2	6190	2476
149,8	237	1,4	19,55	S062	112M	2	6215	2486
145,8	251	2,6	9,94	S082	112M	4	14323	4092
145,5	243	2,3	20,14	S082	112M	2	14376	4107
136,2	269	1,3	10,65	S062	112M	4	6248	2499
133,2	275	3,4	10,88	S102	112M	4	18281	5223
132,5	267	2,2	22,13	S082	112M	2	14775	4221
132,5	267	3,9	22,13	S102	112M	2	18358	5245
132,2	280	2,0	7,34	S082	132MA	6	14742	4212
126,4	280	1,2	23,18	S062	112M	2	6381	2552
124,9	294	2,4	11,61	S082	112M	4	14947	4271

4,00 kW

n2 [rpm]	M2 [Nm]	fs	i	Gear reducer	Motor Size	Pole	Fr2 D [N]	Fr2 C-L [N]
123,8	296	1,3	11,71	S062	112M	4	6325	2530
123,4	287	1,2	23,75	S062	112M	2	6403	2561
122,1	290	2,1	24,00	S082	112M	2	15081	4309
120,7	293	3,8	24,28	S102	112M	2	18824	5378
120,3	308	2,0	8,06	S082	132MA	6	15099	4314
120,3	308	2,9	8,06	S102	132MA	6	18806	5373
116,5	304	1,2	25,14	S062	112M	2	6443	2577
113,7	323	2,3	12,75	S082	112M	4	15384	4395
113,7	323	3,1	12,75	S102	112M	4	19176	5479
112,5	315	1,9	26,05	S082	112M	2	15439	4411
111,3	318	3,5	26,33	S102	112M	2	19292	5512
111,1	331	1,3	13,06	S062	112M	4	6414	2566
109,6	338	2,8	8,85	S102	132MA	6	19338	5525
108,6	338	1,2	13,36	S062	112M	4	6425	2570
107,4	330	2,0	27,29	S082	112M	2	15644	4470
105,9	334	1,1	27,66	S062	112M	2	6518	2607
103,6	354	3,4	13,99	S102	112M	4	19676	5622
103,2	356	2,1	14,04	S082	112M	4	15808	4517
102,1	346	1,9	28,67	S082	112M	2	15911	4546
99,0	358	1,9	29,60	S082	112M	2	16008	4574
98,1	361	3,1	29,87	S102	112M	2	20035	5724
97,7	362	1,0	30,00	S062	112M	2	6580	2632
97,5	380	1,8	9,94	S082	132MA	6	16064	4590
93,9	390	2,0	15,43	S082	112M	4	16228	4637
93,9	390	3,2	15,43	S102	112M	4	20299	5800
92,2	384	1,9	31,78	S082	112M	2	16375	4679
92,2	398	1,9	15,73	S082	112M	4	16282	4652
91,0	403	1,1	15,94	S062	112M	4	6528	2611
90,4	391	2,9	32,40	S102	112M	2	20527	5865
89,7	409	1,1	16,16	S062	112M	4	6534	2614
89,1	416	2,4	10,88	S102	132MA	6	20568	5876
84,2	435	3,0	17,21	S102	112M	4	20922	5978
83,9	422	1,8	34,91	S082	112M	2	16758	4788
83,9	422	2,5	34,91	S102	112M	2	20985	5996
83,8	437	1,8	17,29	S082	112M	4	16713	4775
83,6	443	1,6	11,61	S082	132MA	6	16760	4789
82,5	429	1,7	35,50	S082	112M	2	16836	4810
80,1	442	1,0	36,57	S062	112M	2	6670	2668
76,5	463	2,4	38,30	S102	112M	2	21565	6161
76,3	481	2,9	19,00	S102	112M	4	21536	6153
76,2	482	1,6	19,03	S082	112M	4	17182	4909
76,1	487	1,6	12,75	S082	132MA	6	17142	4898

4,00 kW

n2 [rpm]	M2 [Nm]	fs	i	Gear reducer	Motor Size	Pole	Fr2 D [N]	Fr2 C-L [N]
76,1	487	2,2	12,75	S102	132MA	6	21543	6155
75,2	488	0,9	19,29	S062	112M	4	6578	2631
74,2	495	0,9	19,55	S062	112M	4	6580	2632
73,2	484	1,6	40,05	S082	112M	2	17396	4970
72,0	509	1,5	20,14	S082	112M	4	17444	4984
69,6	527	2,7	20,83	S102	112M	4	22000	6319
69,3	534	2,3	13,99	S102	132MA	6	22000	6342
69,1	536	1,5	14,04	S082	132MA	6	17635	5039
68,9	514	2,0	42,53	S102	112M	2	22000	6352
68,1	520	1,4	43,05	S082	112M	2	17735	5067
68,0	545	3,4	14,27	S142	132MA	6	35000	18500
66,6	532	1,8	44,00	S102	112M	2	22000	6434
65,7	539	3,3	44,63	S122	112M	2	30000	9231
65,5	560	1,4	22,13	S082	112M	4	17848	5100
65,5	560	2,5	22,13	S102	112M	4	22000	6430
62,9	589	1,4	15,43	S082	132MA	6	18000	5149
62,9	589	2,2	15,43	S102	132MA	6	22000	6503
62,1	569	2,1	47,13	S102	112M	2	22000	6562
61,6	601	1,3	15,73	S082	132MA	6	18000	5189
60,6	612	3,3	16,01	S142	132MA	6	35000	18500
60,4	607	1,3	24,00	S082	112M	4	18000	5208
59,7	614	2,4	24,28	S102	112M	4	22000	6602
59,7	592	3,0	49,04	S122	112M	2	30000	9455
58,3	607	1,2	50,25	S082	112M	2	18000	5276
58,3	607	1,7	50,25	S102	112M	2	22000	6664
56,4	657	2,1	17,21	S102	132MA	6	22000	6727
56,1	660	1,2	17,29	S082	132MA	6	18000	5315
55,7	659	1,2	26,05	S082	112M	4	18000	5318
55,1	666	2,2	26,33	S102	112M	4	22000	6769
54,6	649	3,0	53,75	S122	112M	2	30000	9732
54,0	655	1,1	54,27	S082	112M	2	18000	5395
53,6	692	3,3	18,11	S142	132MA	6	35000	18500
53,2	690	1,3	27,29	S082	112M	4	18000	5389
53,1	666	1,4	55,14	S102	112M	2	22000	6861
51,1	726	2,0	19,00	S102	132MA	6	22000	6895
51,0	727	1,1	19,03	S082	132MA	6	18000	5429
50,6	725	1,2	28,67	S082	112M	4	18000	5447
50,2	738	3,3	19,33	S142	132MA	6	35000	18500
49,3	718	1,7	59,40	S102	112M	2	22000	7006
49,0	749	1,2	29,60	S082	112M	4	18000	5489
48,5	756	2,0	29,87	S102	112M	4	22000	7011
48,2	769	1,1	20,14	S082	132MA	6	18000	5505

4,00 kW

n2 [rpm]	M2 [Nm]	fs	i	Gear reducer	Motor Size	Pole	Fr2 D [N]	Fr2 C-L [N]
47,5	772	3,9	30,51	S122	112M	4	30000	10053
47,3	749	1,0	61,98	S082	112M	2	18000	5562
46,6	796	1,8	20,83	S102	132MA	6	22000	7092
45,7	812	3,6	21,25	S122	132MA	6	30000	10184
45,6	804	1,2	31,78	S082	112M	4	18000	5584
45,2	767	2,6	64,84	S123	112M	2	30000	10270
44,7	819	1,8	32,40	S102	112M	4	22000	7169
44,4	797	2,8	66,00	S122	112M	2	30000	10273
44,3	828	3,6	32,76	S122	112M	4	30000	10269
43,9	845	1,0	22,13	S082	132MA	6	18000	5644
43,9	845	1,7	22,13	S102	132MA	6	22000	7210
43,6	849	3,0	22,24	S142	132MA	6	35000	18500
43,4	846	3,5	33,44	S122	112M	4	30000	10327
43,3	854	3,4	22,37	S122	132MA	6	30000	10326
43,1	820	1,4	67,84	S102	112M	2	22000	7268
41,6	890	3,4	23,29	S122	132MA	6	30000	10439
41,5	883	1,1	34,91	S082	112M	4	18000	5710
41,5	883	1,6	34,91	S102	112M	4	22000	7302
41,2	840	2,4	71,07	S123	112M	2	30000	10531
41,2	890	3,4	35,20	S122	112M	4	30000	10451
40,8	898	1,1	35,50	S082	112M	4	18000	5732
40,4	916	0,9	24,00	S082	132MA	6	18000	5751
39,9	927	1,7	24,28	S102	132MA	6	22000	7392
39,5	877	1,4	74,18	S103	112M	2	22000	7439
38,4	965	2,3	25,26	S142	132MA	6	35000	18500
37,9	969	1,5	38,30	S102	112M	4	22000	7486
37,4	928	2,4	78,46	S123	112M	2	30000	10815
37,1	999	3,2	26,15	S122	132MA	6	30000	10736
36,8	1006	1,6	26,33	S102	132MA	6	22000	7533
36,2	1013	1,0	40,05	S082	112M	4	18000	5891
36,0	963	1,2	81,39	S103	112M	2	22000	7649
35,5	1042	0,9	27,29	S082	132MA	6	18000	5905
35,3	1039	2,9	41,07	S122	112M	4	30000	10886
34,2	1082	2,3	28,33	S142	132MA	6	35000	18500
34,1	1076	1,3	42,53	S102	112M	4	22000	7694
33,9	1092	2,9	28,60	S122	132MA	6	30000	10988
33,7	1089	0,9	43,05	S082	112M	4	18000	5985
33,5	1032	2,2	87,27	S123	112M	2	30000	11124
33,3	1103	2,7	43,60	S122	112M	4	30000	11056
32,9	1113	1,2	44,00	S102	112M	4	22000	7777
32,6	1062	1,1	89,77	S103	112M	2	22000	7849
32,5	1129	2,1	44,63	S122	112M	4	30000	11142

4,00 kW

n2 [rpm]	M2 [Nm]	fs	i	Gear reducer	Motor Size	Pole	Fr2 D [N]	Fr2 C-L [N]
32,5	1141	1,4	29,87	S102	132MA	6	22000	7784
31,8	1165	2,7	30,51	S122	132MA	6	30000	11172
31,7	1133	3,5	45,77	S143	112M	4	35000	18500
30,8	1192	1,3	47,13	S102	112M	4	22000	7901
30,3	1224	2,3	32,05	S142	132MA	6	35000	18500
29,9	1237	1,3	32,40	S102	132MA	6	22000	7968
29,6	1240	1,9	49,04	S122	112M	4	30000	11200
29,6	1251	2,5	32,76	S122	132MA	6	30000	11200
29,3	1185	1,0	100,15	S103	112M	2	22000	8075
29,0	1277	2,5	33,44	S122	132MA	6	30000	11200
28,9	1271	1,1	50,25	S102	112M	4	22000	8044
28,5	1262	3,5	50,97	S143	112M	4	35000	18500
28,3	1307	2,3	34,22	S142	132MA	6	35000	18500
27,8	1333	1,1	34,91	S102	132MA	6	22000	8118
27,7	1252	1,8	105,91	S123	112M	2	30000	11200
27,6	1344	2,3	35,20	S122	132MA	6	30000	11200
27,0	1360	1,9	53,75	S122	112M	4	30000	11200
26,3	1394	0,9	55,14	S102	112M	4	22000	8232
26,0	1331	1,7	112,52	S123	112M	2	30000	11200
25,4	1416	3,3	57,17	S143	112M	4	35000	18500
25,3	1463	1,1	38,30	S102	132MA	6	22000	8283
24,6	1504	3,1	39,38	S142	132MA	6	35000	18500
24,4	1503	1,1	59,40	S102	112M	4	22000	8382
23,8	1459	1,5	123,33	S123	112M	2	30000	11200
23,6	1568	2,0	41,07	S122	132MA	6	30000	11200
22,8	1624	0,9	42,53	S102	132MA	6	22000	8493
22,5	1538	1,4	130,04	S123	112M	2	30000	11200
22,4	1606	1,7	64,84	S123	112M	4	30000	11200
22,4	1602	3,0	64,68	S143	112M	4	35000	18500
22,2	1665	1,9	43,60	S122	132MA	6	30000	11200
22,0	1669	1,8	66,00	S122	112M	4	30000	11200
21,9	1582	1,4	133,78	S123	112M	2	30000	11200
21,7	1704	1,5	44,63	S122	132MA	6	30000	11200
21,3	1716	0,9	67,84	S102	112M	4	22000	8649
21,2	1711	2,4	45,77	S143	132MA	6	35000	18500
21,0	1710	2,8	69,06	S143	112M	4	35000	18500
20,6	1800	0,9	47,13	S102	132MA	6	22000	8697
20,4	1760	1,5	71,07	S123	112M	4	30000	11200
19,8	1873	1,3	49,04	S122	132MA	6	30000	11200
19,3	1791	1,3	151,43	S123	112M	2	30000	11200
19,0	1906	2,4	50,97	S143	132MA	6	35000	18500
18,5	1944	1,5	78,46	S123	112M	4	30000	11200

4,00 kW

n2 [rpm]	M2 [Nm]	fs	i	Gear reducer	Motor Size	Pole	Fr2 D [N]	Fr2 C-L [N]
18,2	1968	2,2	79,45	S143	112M	4	35000	18500
18,1	2053	1,3	53,75	S122	132MA	6	30000	11200
17,0	2138	2,3	57,17	S143	132MA	6	35000	18500
16,6	2161	1,4	87,27	S123	112M	4	30000	11200
16,5	2100	1,1	177,53	S123	112M	2	30000	11200
15,2	2395	3,8	64,05	S153	132MA	6	40000	19400
15,0	2418	2,1	64,68	S143	132MA	6	35000	18500
15,0	2425	1,2	64,84	S123	132MA	6	30000	11200
14,7	2447	1,8	98,81	S143	112M	4	35000	18500
14,7	2520	1,2	66,00	S122	132MA	6	30000	11200
14,0	2582	2,0	69,06	S143	132MA	6	35000	18500
13,7	2623	1,1	105,91	S123	112M	4	30000	11200
13,6	2657	1,1	71,07	S123	132MA	6	30000	11200
13,2	2753	3,0	73,63	S153	132MA	6	40000	19400
13,2	2725	1,7	110,05	S143	112M	4	35000	18500
12,9	2787	1,1	112,52	S123	112M	4	30000	11200
12,4	2934	1,1	78,46	S123	132MA	6	30000	11200
12,2	2971	1,5	79,45	S143	132MA	6	35000	18500
11,8	3054	1,0	123,33	S123	112M	4	30000	11200
11,7	3057	1,6	123,44	S143	112M	4	35000	18500
11,2	3221	0,9	130,04	S123	112M	4	30000	11200
11,1	3263	1,0	87,27	S123	132MA	6	30000	11200
11,1	3259	2,3	87,16	S153	132MA	6	40000	19400
10,8	3313	0,9	133,78	S123	112M	4	30000	11200
10,4	3458	1,4	139,64	S143	112M	4	35000	18500
10,0	3637	2,3	97,27	S153	132MA	6	40000	19400
9,8	3695	1,2	98,81	S143	132MA	6	35000	18500
9,8	3692	1,3	149,10	S143	112M	4	35000	18500
9,2	3900	1,0	157,49	S143	112M	4	35000	18500
8,8	4115	1,2	110,05	S143	132MA	6	35000	18500
8,7	4176	2,3	111,67	S153	132MA	6	40000	19400
8,5	4249	1,1	171,55	S143	112M	4	35000	18500
8,3	4344	1,0	175,41	S143	112M	4	35000	18500
7,9	4615	1,1	123,44	S143	132MA	6	35000	18500
7,9	4583	2,2	122,57	S153	132MA	6	40000	19400
7,4	4872	1,0	196,74	S143	112M	4	35000	18500
7,0	5205	1,8	139,21	S153	132MA	6	40000	19400
7,0	5222	1,0	139,64	S143	132MA	6	35000	18500
6,5	5575	0,9	149,10	S143	132MA	6	35000	18500
6,3	5759	1,3	154,02	S153	132MA	6	40000	19400
6,1	5983	1,4	160,02	S153	132MA	6	40000	19400
5,5	6611	1,3	176,81	S153	132MA	6	40000	19400

4,00 kW

n2 [rpm]	M2 [Nm]	fs	i	Gear reducer	Size	Motor	Pole	Fr2 D [N]	Fr2 C-L [N]
5,0	7256	1,3	194,06	S153	132MA		6	40000	19400
4,4	8241	1,2	220,42	S153	132MA		6	40000	19400
3,8	9473	0,9	253,36	S153	132MA		6	40000	19400

5,50 kW

n2 [rpm]	M2 [Nm]	fs	i	Gear reducer	Size	Motor	Pole	Fr2 D [N]	Fr2 C-L [N]
402,0	121	3,4	7,34	S082	132S		2	10466	2990
365,9	133	3,3	8,06	S082	132S		2	10769	3077
296,7	164	3,0	9,94	S082	132S		2	11434	3267
271,0	180	4,0	10,88	S102	132S		2	14530	4151
254,1	191	2,7	11,61	S082	132S		2	12006	3430
231,4	210	2,7	12,75	S082	132S		2	12305	3516
231,4	210	3,6	12,75	S102	132S		2	15270	4363
210,9	231	3,9	13,99	S102	132S		2	15708	4488
210,1	232	2,5	14,04	S082	132S		2	12643	3612
200,3	252	2,2	7,34	S082	132MS		4	12789	3654
191,2	255	2,2	15,43	S082	132S		2	13042	3726
191,2	255	3,6	15,43	S102	132S		2	16232	4638
187,6	259	2,2	15,73	S082	132S		2	13113	3747
182,3	277	2,2	8,06	S082	132MS		4	13137	3753
182,3	277	3,1	8,06	S102	132MS		4	16374	4678
171,4	284	3,4	17,21	S102	132S		2	16776	4793
170,6	285	2,0	17,29	S082	132S		2	13472	3849
166,1	304	2,9	8,85	S102	132MS		4	16870	4820
155,3	314	3,3	19,00	S102	132S		2	17280	4937
155,0	314	1,8	19,03	S082	132S		2	13786	3939
147,8	341	1,9	9,94	S082	132MS		4	13984	3995
146,5	332	1,7	20,14	S082	132S		2	14059	4017
141,6	344	3,1	20,83	S102	132S		2	17686	5053
135,0	374	2,5	10,88	S102	132MS		4	17975	5136
133,3	365	1,6	22,13	S082	132S		2	14375	4107
133,3	365	2,9	22,13	S102	132S		2	18004	5144
132,6	384	3,8	7,32	S142	132MB		6	35000	18500
132,2	385	1,5	7,34	S082	132MB		6	14353	4101
126,6	399	1,7	11,61	S082	132MS		4	14585	4167
122,9	396	1,5	24,00	S082	132S		2	14697	4199
121,5	401	2,8	24,28	S102	132S		2	18520	5291
120,3	424	1,5	8,06	S082	132MB		6	14761	4217
120,3	424	2,1	8,06	S102	132MB		6	18562	5304
118,2	431	3,8	8,21	S142	132MB		6	35000	18500
115,3	437	1,7	12,75	S082	132MS		4	14929	4265

5,50 kW

n2 [rpm]	M2 [Nm]	fs	i	Gear reducer	Motor Size	Pole	Fr2 D [N]	Fr2 C-L [N]
115,3	437	2,3	12,75	S102	132MS	4	18785	5367
113,2	430	1,4	26,05	S082	132S	2	15079	4308
112,0	435	2,6	26,33	S102	132S	2	18964	5418
109,6	464	2,0	8,85	S102	132MB	6	19066	5447
108,1	450	1,5	27,29	S082	132S	2	15224	4350
105,1	480	2,5	13,99	S102	132MS	4	19256	5502
104,7	482	1,6	14,04	S082	132MS	4	15286	4367
104,5	488	3,8	9,29	S142	132MB	6	35000	18500
103,0	490	3,6	14,27	S142	132MS	4	35000	18500
102,8	473	1,4	28,67	S082	132S	2	15424	4407
99,6	488	1,4	29,60	S082	132S	2	15553	4444
98,8	493	2,3	29,87	S102	132S	2	19646	5613
97,8	521	3,8	9,91	S142	132MB	6	35000	18500
97,5	523	1,3	9,94	S082	132MB	6	15591	4455
95,3	530	1,4	15,43	S082	132MS	4	15716	4490
95,3	530	2,3	15,43	S102	132MS	4	19878	5679
93,5	540	1,4	15,73	S082	132MS	4	15792	4512
92,8	524	1,4	31,78	S082	132S	2	15841	4526
91,8	549	3,5	16,01	S142	132MS	4	35000	18500
91,0	535	2,1	32,40	S102	132S	2	20185	5767
89,1	571	1,7	10,88	S102	132MB	6	20222	5778
85,4	591	2,2	17,21	S102	132MS	4	20499	5857
85,0	593	1,3	17,29	S082	132MS	4	16119	4605
85,0	599	3,6	11,41	S142	132MB	6	35000	18500
84,5	576	1,3	34,91	S082	132S	2	16267	4648
84,5	576	1,8	34,91	S102	132S	2	20614	5890
83,8	581	3,9	35,20	S122	132S	2	29431	8409
83,6	610	1,2	11,61	S082	132MB	6	16208	4631
81,2	621	3,5	18,11	S142	132MS	4	35000	18500
77,4	652	2,1	19,00	S102	132MS	4	21068	6020
77,3	653	1,2	19,03	S082	132MS	4	16502	4715
77,0	632	1,8	38,30	S102	132S	2	21075	6021
76,1	669	1,2	12,75	S082	132MB	6	16583	4738
76,1	669	1,6	12,75	S102	132MB	6	21129	6037
76,0	663	3,5	19,33	S142	132MS	4	35000	18500
75,7	673	3,0	12,81	S142	132MB	6	35000	18500
73,0	691	1,1	20,14	S082	132MS	4	16757	4788
71,8	678	3,3	41,07	S122	132S	2	30000	8776
70,6	714	1,9	20,83	S102	132MS	4	21605	6173
69,3	702	1,5	42,53	S102	132S	2	21712	6203
69,3	734	1,7	13,99	S102	132MB	6	21670	6191
69,2	729	3,8	21,25	S122	132MS	4	30000	8847

5,50 kW

n2 [rpm]	M2 [Nm]	fs	i	Gear reducer	Motor Size	Pole	Fr2 D [N]	Fr2 C-L [N]
69,1	737	1,1	14,04	S082	132MB	6	16967	4848
68,5	711	1,1	43,05	S082	132S	2	17081	4880
68,0	749	2,5	14,27	S142	132MB	6	35000	18500
67,6	720	3,1	43,60	S122	132S	2	30000	8920
66,4	759	1,1	22,13	S082	132MS	4	17105	4887
66,4	759	1,8	22,13	S102	132MS	4	21879	6251
66,1	737	2,4	44,63	S122	132S	2	30000	8976
66,1	763	3,1	22,24	S142	132MS	4	35000	18500
65,7	767	3,6	22,37	S122	132MS	4	30000	8986
63,1	799	3,6	23,29	S122	132MS	4	30000	9050
62,9	810	1,0	15,43	S082	132MB	6	17297	4942
62,9	810	1,6	15,43	S102	132MB	6	22000	6339
62,6	777	1,5	47,13	S102	132S	2	22000	6379
61,7	826	1,0	15,73	S082	132MB	6	17372	4963
61,2	824	1,0	24,00	S082	132MS	4	17481	4994
60,6	840	2,4	16,01	S142	132MB	6	35000	18500
60,6	833	1,8	24,28	S102	132MS	4	22000	6408
60,2	809	2,2	49,04	S122	132S	2	30000	9206
58,2	866	2,4	25,26	S142	132MS	4	35000	18500
56,4	904	1,5	17,21	S102	132MB	6	22000	6524
56,2	898	3,3	26,15	S122	132MS	4	30000	9364
55,9	904	1,6	26,33	S102	132MS	4	22000	6571
54,9	887	2,2	53,75	S122	132S	2	30000	9423
53,8	936	0,9	27,29	S082	132MS	4	17980	5137
53,6	951	2,4	18,11	S142	132MB	6	35000	18500
51,9	972	2,4	28,33	S142	132MS	4	35000	18500
51,4	981	3,0	28,60	S122	132MS	4	30000	9582
51,3	984	0,9	28,67	S082	132MS	4	18000	5176
51,1	998	1,5	19,00	S102	132MB	6	22000	6693
50,2	1015	2,4	19,33	S142	132MB	6	35000	18500
49,2	1025	1,5	29,87	S102	132MS	4	22000	6764
48,2	1047	2,9	30,51	S122	132MS	4	30000	9706
46,6	1094	1,3	20,83	S102	132MB	6	22000	6851
46,3	1090	0,9	31,78	S082	132MS	4	18000	5287
45,8	1100	2,4	32,05	S142	132MS	4	35000	18500
45,6	1116	2,6	21,25	S122	132MB	6	30000	9826
45,5	1048	1,9	64,84	S123	132S	2	30000	9947
45,4	1112	1,3	32,40	S102	132MS	4	22000	6928
44,9	1124	2,7	32,76	S122	132MS	4	30000	9880
44,7	1089	2,0	66,00	S122	132S	2	30000	9966
44,0	1147	2,6	33,44	S122	132MS	4	30000	9964
43,8	1162	1,3	22,13	S102	132MB	6	22000	6955

5,50 kW

n2 [rpm]	M2 [Nm]	fs	i	Gear reducer	Motor Size	Pole	Fr2 D [N]	Fr2 C-L [N]
43,6	1168	2,2	22,24	S142	132MB	6	35000	18500
43,3	1175	2,5	22,37	S122	132MB	6	30000	9976
43,0	1174	2,4	34,22	S142	132MS	4	35000	18500
42,1	1198	1,2	34,91	S102	132MS	4	22000	7045
41,8	1208	2,5	35,20	S122	132MS	4	30000	10073
41,6	1223	2,5	23,29	S122	132MB	6	30000	10075
41,5	1148	1,7	71,07	S123	132S	2	30000	10177
40,0	1275	1,2	24,28	S102	132MB	6	22000	7114
38,4	1314	1,1	38,30	S102	132MS	4	22000	7193
38,4	1326	1,7	25,26	S142	132MB	6	35000	18500
37,6	1268	1,8	78,46	S123	132S	2	30000	10400
37,3	1351	3,3	39,38	S142	132MS	4	35000	18500
37,1	1373	2,3	26,15	S122	132MB	6	30000	10330
36,8	1383	1,1	26,33	S102	132MB	6	22000	7253
35,8	1409	2,1	41,07	S122	132MS	4	30000	10431
34,5	1459	1,0	42,53	S102	132MS	4	22000	7384
34,2	1488	1,7	28,33	S142	132MB	6	35000	18500
33,9	1502	2,1	28,60	S122	132MB	6	30000	10545
33,8	1410	1,6	87,27	S123	132S	2	30000	10692
33,7	1496	2,0	43,60	S122	132MS	4	30000	10592
32,9	1531	1,6	44,63	S122	132MS	4	30000	10631
32,4	1569	1,0	29,87	S102	132MB	6	22000	7484
32,1	1538	2,6	45,77	S143	132MS	4	35000	18500
31,8	1602	1,9	30,51	S122	132MB	6	30000	10724
31,2	1617	1,0	47,13	S102	132MS	4	22000	7547
30,3	1683	1,7	32,05	S142	132MB	6	35000	18500
30,0	1683	1,4	49,04	S122	132MS	4	30000	10872
29,9	1701	0,9	32,40	S102	132MB	6	22000	7620
29,6	1720	1,8	32,76	S122	132MB	6	30000	10890
29,0	1756	1,8	33,44	S122	132MB	6	30000	10915
28,8	1712	2,6	50,97	S143	132MS	4	35000	18500
28,3	1797	1,7	34,22	S142	132MB	6	35000	18500
27,9	1711	1,3	105,91	S123	132S	2	30000	11136
27,6	1848	1,7	35,20	S122	132MB	6	30000	11033
27,3	1844	1,4	53,75	S122	132MS	4	30000	11071
26,3	1817	1,2	112,52	S123	132S	2	30000	11200
25,8	1921	2,4	57,17	S143	132MS	4	35000	18500
24,7	2068	2,2	39,38	S142	132MB	6	35000	18500
24,2	2062	3,2	40,10	S153	132MB	6	40000	19400
23,9	1992	1,1	123,33	S123	132S	2	30000	11200
23,6	2157	1,4	41,07	S122	132MB	6	30000	11200
22,8	2172	2,2	64,68	S143	132MS	4	35000	18500

5,50 kW

n2 [rpm]	M2 [Nm]	fs	i	Gear reducer	Motor Size	Pole	Fr2 D [N]	Fr2 C-L [N]
22,7	2100	1,1	130,04	S123	132S	2	30000	11200
22,7	2178	1,2	64,84	S123	132MS	4	30000	11200
22,3	2264	1,3	66,00	S122	132MS	4	30000	11200
22,2	2289	1,4	43,60	S122	132MB	6	30000	11200
22,1	2161	1,0	133,78	S123	132S	2	30000	11200
21,7	2344	1,1	44,63	S122	132MB	6	30000	11200
21,6	2301	3,2	44,76	S153	132MB	6	40000	19400
21,2	2319	2,1	69,06	S143	132MS	4	35000	18500
21,2	2353	1,8	45,77	S143	132MB	6	35000	18500
20,7	2387	1,1	71,07	S123	132MS	4	30000	11200
19,9	2473	3,1	73,63	S153	132MS	4	40000	19400
19,8	2575	1,0	49,04	S122	132MB	6	30000	11200
19,0	2621	1,8	50,97	S143	132MB	6	35000	18500
18,9	2642	3,1	51,38	S153	132MB	6	40000	19400
18,8	2636	1,1	78,46	S123	132MS	4	30000	11200
18,5	2669	1,6	79,45	S143	132MS	4	35000	18500
18,0	2822	1,0	53,75	S122	132MB	6	30000	11200
17,2	2899	3,0	56,39	S153	132MB	6	40000	19400
17,0	2939	1,7	57,17	S143	132MB	6	35000	18500
16,8	2928	2,4	87,16	S153	132MS	4	40000	19400
16,8	2931	1,0	87,27	S123	132MS	4	30000	11200
15,1	3268	2,4	97,27	S153	132MS	4	40000	19400
15,1	3293	2,8	64,05	S153	132MB	6	40000	19400
15,0	3325	1,5	64,68	S143	132MB	6	35000	18500
14,9	3319	1,3	98,81	S143	132MS	4	35000	18500
14,7	3465	0,9	66,00	S122	132MB	6	30000	11200
14,0	3550	1,4	69,06	S143	132MB	6	35000	18500
13,4	3697	1,3	110,05	S143	132MS	4	35000	18500
13,2	3785	2,2	73,63	S153	132MB	6	40000	19400
13,2	3751	2,4	111,67	S153	132MS	4	40000	19400
12,2	4085	1,1	79,45	S143	132MB	6	35000	18500
12,0	4117	2,3	122,57	S153	132MS	4	40000	19400
11,9	4146	1,1	123,44	S143	132MS	4	35000	18500
11,1	4481	1,7	87,16	S153	132MB	6	40000	19400
10,6	4676	2,0	139,21	S153	132MS	4	40000	19400
10,5	4690	1,0	139,64	S143	132MS	4	35000	18500
10,0	5001	1,7	97,27	S153	132MB	6	40000	19400
9,9	5008	1,0	149,10	S143	132MS	4	35000	18500
9,8	5080	0,9	98,81	S143	132MB	6	35000	18500
9,5	5173	1,4	154,02	S153	132MS	4	40000	19400
9,2	5375	1,5	160,02	S153	132MS	4	40000	19400
8,7	5741	1,6	111,67	S153	132MB	6	40000	19400

5,50 kW

n2 [rpm]	M2 [Nm]	fs	i	Gear reducer	Size	Motor Pole	Fr2 D [N]	Fr2 C-L [N]
8,3	5939	1,4	176,81	S153	132MS	4	40000	19400
7,9	6302	1,6	122,57	S153	132MB	6	40000	19400
7,6	6519	1,4	194,06	S153	132MS	4	40000	19400
7,0	7157	1,3	139,21	S153	132MB	6	40000	19400
6,6	7404	1,3	220,42	S153	132MS	4	40000	19400
6,3	7918	0,9	154,02	S153	132MB	6	40000	19400
6,1	8227	1,0	160,02	S153	132MB	6	40000	19400
5,8	8510	1,0	253,36	S153	132MS	4	40000	19400
5,5	9091	0,9	176,81	S153	132MB	6	40000	19400
5,0	9977	0,9	194,06	S153	132MB	6	40000	19400

7,50 kW

n2 [rpm]	M2 [Nm]	fs	i	Gear reducer	Size	Motor Pole	Fr2 D [N]	Fr2 C-L [N]
402,0	165	2,5	7,34	S082	132M	2	10278	2937
365,9	182	2,5	8,06	S082	132M	2	10586	3025
365,9	182	3,5	8,06	S102	132M	2	13139	3754
333,4	199	3,3	8,85	S102	132M	2	13544	3870
296,7	224	2,2	9,94	S082	132M	2	11226	3207
271,0	245	2,9	10,88	S102	132M	2	14361	4103
254,1	261	2,0	11,61	S082	132M	2	11774	3364
231,3	287	1,9	12,75	S082	132M	2	12087	3453
231,3	287	2,6	12,75	S102	132M	2	15117	4319
210,9	315	2,9	13,99	S102	132M	2	15474	4421
210,1	316	1,8	14,04	S082	132M	2	12367	3533
198,9	346	1,6	7,34	S082	132M	4	12511	3575
191,2	347	1,6	15,43	S082	132M	2	12733	3638
191,2	347	2,7	15,43	S102	132M	2	15989	4568
187,6	354	1,6	15,73	S082	132M	2	12799	3657
181,1	380	1,6	8,06	S082	132M	4	12830	3666
181,1	380	2,2	8,06	S102	132M	4	16145	4613
171,4	387	2,5	17,21	S102	132M	2	16472	4706
170,6	389	1,5	17,29	S082	132M	2	13103	3744
165,0	417	2,1	8,85	S102	132M	4	16615	4747
155,3	427	2,4	19,00	S102	132M	2	16980	4851
155,0	428	1,3	19,03	S082	132M	2	13459	3845
146,8	469	1,4	9,94	S082	132M	4	13571	3877
146,5	453	1,3	20,14	S082	132M	2	13609	3888
141,7	469	2,2	20,83	S102	132M	2	17395	4970
134,1	513	1,9	10,88	S102	132M	4	17584	5024
133,3	498	1,2	22,13	S082	132M	2	13939	3982
133,3	498	2,1	22,13	S102	132M	2	17660	5046

7,50 kW

n2 [rpm]	M2 [Nm]	fs	i	Gear reducer	Size	Motor Pole	Fr2 D [N]	Fr2 C-L [N]
128,0	537	3,8	11,41	S142	132M	4	35000	18500
125,8	547	1,3	11,61	S082	132M	4	14080	4023
122,9	540	1,1	24,00	S082	132M	2	14248	4071
121,5	547	2,0	24,28	S102	132M	2	18192	5198
114,5	601	1,2	12,75	S082	132M	4	14426	4122
114,5	601	1,7	12,75	S102	132M	4	18404	5258
114,0	604	3,1	12,81	S142	132M	4	35000	18500
113,3	586	1,0	26,05	S082	132M	2	14510	4146
112,8	588	3,8	26,15	S122	132M	2	26423	7549
112,0	592	1,9	26,33	S102	132M	2	18535	5296
108,1	614	1,1	27,29	S082	132M	2	14673	4192
104,4	659	1,8	13,99	S102	132M	4	18837	5382
103,9	661	1,1	14,04	S082	132M	4	14757	4216
103,1	644	3,5	28,60	S122	132M	2	27122	7749
102,9	645	1,0	28,67	S082	132M	2	14893	4255
102,3	672	2,6	14,27	S142	132M	4	35000	18500
99,7	666	1,0	29,60	S082	132M	2	14956	4273
98,8	672	1,7	29,87	S102	132M	2	19181	5480
96,7	687	3,2	30,51	S122	132M	2	27647	7899
94,6	727	1,1	15,43	S082	132M	4	15052	4301
94,6	727	1,7	15,43	S102	132M	4	19336	5525
92,9	715	1,0	31,78	S082	132M	2	15248	4357
92,8	741	1,0	15,73	S082	132M	4	15116	4319
91,2	754	2,6	16,01	S142	132M	4	35000	18500
91,0	729	1,5	32,40	S102	132M	2	19638	5611
90,1	737	3,1	32,76	S122	132M	2	28070	8020
88,2	753	3,0	33,44	S122	132M	2	28325	8093
84,8	811	1,6	17,21	S102	132M	4	19898	5685
84,5	786	1,3	34,91	S102	132M	2	20027	5722
84,4	815	0,9	17,29	S082	132M	4	15433	4409
83,8	792	2,8	35,20	S122	132M	2	28705	8201
80,7	853	2,6	18,11	S142	132M	4	35000	18500
77,0	862	1,3	38,30	S102	132M	2	20478	5851
76,8	895	1,6	19,00	S102	132M	4	20409	5831
75,5	911	2,6	19,33	S142	132M	4	35000	18500
71,8	924	2,4	41,07	S122	132M	2	29753	8501
70,1	981	1,4	20,83	S102	132M	4	20921	5977
69,4	957	1,1	42,53	S102	132M	2	21029	6008
68,7	1001	2,8	21,25	S122	132M	4	30000	8572
67,7	981	2,3	43,60	S122	132M	2	30000	8628
66,1	1004	1,8	44,63	S122	132M	2	30000	8708
66,0	1042	1,3	22,13	S102	132M	4	21199	6057

7,50 kW

n2 [rpm]	M2 [Nm]	fs	i	Gear reducer	Size	Motor Pole	Fr2 D [N]	Fr2 C-L [N]
65,6	1048	2,3	22,24	S142	132M	4	35000	18500
65,2	1054	2,6	22,37	S122	132M	4	30000	8680
62,7	1097	2,6	23,29	S122	132M	4	30000	8765
62,5	1060	1,1	47,13	S102	132M	2	21644	6184
60,1	1143	1,3	24,28	S102	132M	4	21714	6204
60,1	1104	1,6	49,04	S122	132M	2	30000	8894
57,8	1190	1,8	25,26	S142	132M	4	35000	18500
55,8	1232	2,4	26,15	S122	132M	4	30000	8992
55,5	1240	1,2	26,33	S102	132M	4	22000	6324
54,8	1209	1,6	53,75	S122	132M	2	30000	9103
51,6	1335	1,8	28,33	S142	132M	4	35000	18500
51,0	1347	2,2	28,60	S122	132M	4	30000	9176
48,9	1407	1,1	29,87	S102	132M	4	22000	6497
47,8	1437	2,1	30,51	S122	132M	4	30000	9322
45,6	1510	1,8	32,05	S142	132M	4	35000	18500
45,5	1428	1,4	64,84	S123	132M	2	30000	9529
45,1	1526	1,0	32,40	S102	132M	4	22000	6614
44,7	1485	1,5	66,00	S122	132M	2	30000	9504
44,6	1543	1,9	32,76	S122	132M	4	30000	9451
43,7	1575	1,9	33,44	S122	132M	4	30000	9507
42,7	1612	1,8	34,22	S142	132M	4	35000	18500
41,5	1658	1,8	35,20	S122	132M	4	30000	9594
41,5	1566	1,3	71,07	S123	132M	2	30000	9719
37,6	1728	1,3	78,46	S123	132M	2	30000	9920
37,1	1854	2,4	39,38	S142	132M	4	35000	18500
36,4	1849	3,4	40,10	S153	132M	4	40000	19400
35,6	1934	1,6	41,07	S122	132M	4	30000	9889
33,8	1922	1,2	87,27	S123	132M	2	30000	10103
33,5	2053	1,5	43,60	S122	132M	4	30000	9999
32,7	2102	1,1	44,63	S122	132M	4	30000	10041
32,6	2064	3,4	44,76	S153	132M	4	40000	19400
31,9	2111	1,9	45,77	S143	132M	4	35000	18500
29,8	2310	1,0	49,04	S122	132M	4	30000	10205
28,6	2351	1,9	50,97	S143	132M	4	35000	18500
28,4	2370	3,3	51,38	S153	132M	4	40000	19400
27,2	2532	1,0	53,75	S122	132M	4	30000	10367
25,9	2601	3,2	56,39	S153	132M	4	40000	19400
25,6	2637	1,8	57,17	S143	132M	4	35000	18500
22,8	2954	3,0	64,05	S153	132M	4	40000	19400
22,6	2983	1,6	64,68	S143	132M	4	35000	18500
22,5	2990	0,9	64,84	S123	132M	4	30000	10696
22,2	3109	1,0	66,00	S122	132M	4	30000	10658

7,50 kW

n2 [rpm]	M2 [Nm]	fs	i	Gear reducer	Size	Motor Pole	Fr2 D [N]	Fr2 C-L [N]
21,1	3184	1,5	69,06	S143	132M	4	35000	18500
19,8	3396	2,3	73,63	S153	132M	4	40000	19400
18,4	3664	1,2	79,45	S143	132M	4	35000	18500
16,7	4019	1,8	87,16	S153	132M	4	40000	19400
15,0	4486	1,8	97,27	S153	132M	4	40000	19400
14,8	4557	1,0	98,81	S143	132M	4	35000	18500
13,3	5075	0,9	110,05	S143	132M	4	35000	18500
13,1	5150	1,8	111,67	S153	132M	4	40000	19400
11,9	5652	1,7	122,57	S153	132M	4	40000	19400
10,5	6420	1,4	139,21	S153	132M	4	40000	19400
9,5	7102	1,0	154,02	S153	132M	4	40000	19400
9,2	7379	1,1	160,02	S153	132M	4	40000	19400
8,3	8154	1,0	176,81	S153	132M	4	40000	19400
7,6	8950	1,0	194,06	S153	132M	4	40000	19400
6,6	10165	0,9	220,42	S153	132M	4	40000	19400

11,00 kW

n2 [rpm]	M2 [Nm]	fs	i	Gear reducer	Size	Motor Pole	Fr2 D [N]	Fr2 C-L [N]
235,6	432	3,4	4,12	S142	160L	6	32378	18500
211,5	482	3,4	4,59	S142	160L	6	33285	18500
201,6	500	3,8	7,32	S142	160MA	4	33731	18500
188,6	540	3,4	5,14	S142	160L	6	34255	18500
182,9	551	1,5	8,06	S102	160MA	4	15642	4469
179,7	561	3,8	8,21	S142	160MA	4	34706	18500
173,9	580	2,6	8,48	S122	160MA	4	22641	6469
166,7	605	1,5	8,85	S102	160MA	4	16034	4581
166,7	611	3,4	5,82	S142	160L	6	35000	18500
158,9	635	3,8	9,29	S142	160MA	4	35000	18500
158,6	636	2,7	9,30	S122	160MA	4	23193	6627
156,1	652	3,4	6,21	S142	160L	6	35000	18500
148,8	678	3,8	9,91	S142	160MA	4	35000	18500
144,1	700	2,4	10,24	S122	160MA	4	23777	6793
135,5	744	1,3	10,88	S102	160MA	4	16919	4834
132,6	768	2,6	7,32	S142	160L	6	35000	18500
129,3	780	3,6	11,41	S142	160MA	4	35000	18500
129,2	781	2,4	11,42	S122	160MA	4	24439	6983
120,3	847	1,1	8,06	S102	160L	6	17408	4974
118,3	852	3,9	12,46	S152	160MA	4	40000	19400
118,2	862	2,6	8,21	S142	160L	6	35000	18500
116,8	863	2,5	12,63	S122	160MA	4	25052	7158
115,7	872	1,1	12,75	S102	160MA	4	17598	5028

11,00 kW

n2 [rpm]	M2 [Nm]	fs	i	Gear reducer	Motor Size	Pole	Fr2 D [N]	Fr2 C-L [N]
115,1	876	3,0	12,81	S142	160MA	4	35000	18500
114,4	891	1,8	8,48	S122	160L	6	25148	7185
109,6	929	1,0	8,85	S102	160L	6	17804	5087
106,6	946	2,5	13,84	S122	160MA	4	25608	7317
106,0	951	3,9	13,91	S152	160MA	4	40000	19400
105,4	956	1,3	13,99	S102	160MA	4	17996	5142
104,5	975	2,6	9,29	S142	160L	6	35000	18500
104,3	976	1,8	9,30	S122	160L	6	25700	7343
103,4	976	2,5	14,27	S142	160MA	4	35000	18500
97,8	1041	2,6	9,91	S142	160L	6	35000	18500
94,7	1075	1,7	10,24	S122	160L	6	26276	7508
92,4	1092	3,9	15,97	S152	160MA	4	40000	19400
92,2	1094	2,4	16,01	S142	160MA	4	35000	18500
86,8	1162	2,2	16,99	S122	160MA	4	26837	7668
85,7	1177	1,1	17,21	S102	160MA	4	18874	5393
85,0	1199	1,7	11,42	S122	160L	6	26918	7691
85,0	1198	2,5	11,41	S142	160L	6	35000	18500
84,2	1198	3,9	17,53	S152	160MA	4	40000	19400
81,5	1238	2,4	18,11	S142	160MA	4	35000	18500
77,8	1309	2,7	12,46	S152	160L	6	40000	19400
76,8	1326	1,7	12,63	S122	160L	6	27500	7857
76,3	1322	2,4	19,33	S142	160MA	4	35000	18500
75,7	1345	2,0	12,81	S142	160L	6	35000	18500
74,1	1361	3,9	19,91	S152	160MA	4	40000	19400
70,1	1453	1,7	13,84	S122	160L	6	28017	8005
69,7	1461	2,7	13,91	S152	160L	6	40000	19400
69,4	1453	1,9	21,25	S122	160MA	4	28127	8036
68,0	1499	1,7	14,27	S142	160L	6	35000	18500
66,3	1521	2,2	22,24	S142	160MA	4	35000	18500
65,9	1529	1,8	22,37	S122	160MA	4	28411	8117
64,5	1564	3,9	22,88	S152	160MA	4	40000	19400
63,3	1592	1,8	23,29	S122	160MA	4	28631	8180
60,7	1677	2,7	15,97	S152	160L	6	40000	19400
60,6	1681	1,7	16,01	S142	160L	6	35000	18500
58,4	1727	1,7	25,26	S142	160MA	4	35000	18500
57,1	1784	1,5	16,99	S122	160L	6	29113	8318
56,4	1788	1,7	26,15	S122	160MA	4	29242	8355
55,3	1840	2,7	17,53	S152	160L	6	40000	19400
54,4	1853	3,3	27,11	S152	160MA	4	40000	19400
53,6	1901	1,7	18,11	S142	160L	6	35000	18500
52,1	1937	1,7	28,33	S142	160MA	4	35000	18500
51,6	1955	1,5	28,60	S122	160MA	4	29687	8482

11,00 kW

n2 [rpm]	M2 [Nm]	fs	i	Gear reducer	Motor Size	Pole	Fr2 D [N]	Fr2 C-L [N]
50,2	2030	1,7	19,33	S142	160L	6	35000	18500
49,6	2034	3,3	29,75	S152	160MA	4	40000	19400
48,7	2090	2,7	19,91	S152	160L	6	40000	19400
48,3	2086	1,4	30,51	S122	160MA	4	29992	8569
46,0	2191	1,7	32,05	S142	160MA	4	35000	18500
45,6	2231	1,3	21,25	S122	160L	6	30000	8619
45,0	2240	1,3	32,76	S122	160MA	4	30000	8660
44,1	2287	1,3	33,44	S122	160MA	4	30000	8685
43,7	2310	3,3	33,79	S152	160MA	4	40000	19400
43,6	2336	1,5	22,24	S142	160L	6	35000	18500
43,4	2349	1,3	22,37	S122	160L	6	30000	8680
43,1	2340	1,7	34,22	S142	160MA	4	35000	18500
42,4	2403	2,7	22,88	S152	160L	6	40000	19400
41,9	2407	1,2	35,20	S122	160MA	4	30000	8745
41,6	2446	1,2	23,29	S122	160L	6	30000	8726
38,4	2653	1,1	25,26	S142	160L	6	35000	18500
38,0	2656	2,9	38,84	S152	160MA	4	40000	19400
37,5	2692	1,6	39,38	S142	160MA	4	35000	18500
37,1	2746	1,1	26,15	S122	160L	6	30000	8844
36,8	2685	2,3	40,10	S153	160MA	4	40000	19400
35,9	2808	1,1	41,07	S122	160MA	4	30000	8903
35,8	2846	2,2	27,11	S152	160L	6	40000	19400
34,2	2975	1,1	28,33	S142	160L	6	35000	18500
33,9	3003	1,0	28,60	S122	160L	6	30000	8920
33,0	2996	2,3	44,76	S153	160MA	4	40000	19400
32,6	3124	2,2	29,75	S152	160L	6	40000	19400
32,2	3064	1,3	45,77	S143	160MA	4	35000	18500
31,8	3204	1,0	30,51	S122	160L	6	30000	8965
30,3	3366	1,1	32,05	S142	160L	6	35000	18500
29,6	3440	0,9	32,76	S122	160L	6	30000	9005
28,9	3412	1,3	50,97	S143	160MA	4	35000	18500
28,7	3548	2,2	33,79	S152	160L	6	40000	19400
28,7	3440	2,3	51,38	S153	160MA	4	40000	19400
28,3	3594	1,1	34,22	S142	160L	6	35000	18500
26,2	3775	2,2	56,39	S153	160MA	4	40000	19400
25,8	3828	1,2	57,17	S143	160MA	4	35000	18500
25,0	4078	2,0	38,84	S152	160L	6	40000	19400
24,6	4135	1,1	39,38	S142	160L	6	35000	18500
24,2	4123	1,6	40,10	S153	160L	6	40000	19400
23,0	4288	2,1	64,05	S153	160MA	4	40000	19400
22,8	4330	1,1	64,68	S143	160MA	4	35000	18500
21,7	4602	1,6	44,76	S153	160L	6	40000	19400

11,00 kW

n2 [rpm]	M2 [Nm]	fs	i	Gear reducer	Size	Motor Pole	Fr2 D [N]	Fr2 C-L [N]
21,4	4623	1,1	69,06	S143	160MA	4	35000	18500
20,0	4929	1,6	73,63	S153	160MA	4	40000	19400
18,9	5283	1,6	51,38	S153	160L	6	40000	19400
17,2	5798	1,5	56,39	S153	160L	6	40000	19400
16,9	5835	1,2	87,16	S153	160MA	4	40000	19400
15,2	6512	1,2	97,27	S153	160MA	4	40000	19400
15,1	6586	1,4	64,05	S153	160L	6	40000	19400
13,2	7570	1,1	73,63	S153	160L	6	40000	19400
13,2	7476	1,2	111,67	S153	160MA	4	40000	19400
12,0	8205	1,2	122,57	S153	160MA	4	40000	19400
10,6	9320	1,0	139,21	S153	160MA	4	40000	19400

15,00 kW

n2 [rpm]	M2 [Nm]	fs	i	Gear reducer	Size	Motor Pole	Fr2 D [N]	Fr2 C-L [N]
358,2	384	3,6	4,12	S142	160LA	4	28137	16078
321,6	428	3,6	4,59	S142	160LA	4	28921	16526
286,8	480	3,6	5,14	S142	160LA	4	29758	17004
253,5	543	3,6	5,82	S142	160LA	4	30654	17517
238,0	584	2,5	4,12	S142	180L ⁽²⁾	6	31064	17751
237,4	579	3,6	6,21	S142	160LA	4	31128	17787
213,7	650	2,5	4,59	S142	180L ⁽²⁾	6	31832	18190
201,6	682	2,8	7,32	S142	160LA	4	32297	18455
190,5	729	2,5	5,14	S142	180L ⁽²⁾	6	32635	18500
182,9	752	1,1	8,06	S102	160LA	4	15122	4321
179,7	765	2,8	8,21	S142	160LA	4	33097	18500
173,9	791	1,9	8,48	S122	160LA	4	21842	6241
171,6	809	3,8	5,71	S152	180L ⁽²⁾	6	40000	19400
168,4	825	2,5	5,82	S142	180L ⁽²⁾	6	33475	18500
166,7	825	1,1	8,85	S102	160LA	4	15463	4418
158,9	866	2,8	9,29	S142	160LA	4	33930	18500
158,6	867	2,0	9,30	S122	160LA	4	22318	6376
157,7	881	2,5	6,21	S142	180L ⁽²⁾	6	33908	18500
150,2	925	3,5	6,52	S152	180L ⁽²⁾	6	40000	19400
148,8	924	2,8	9,91	S142	160LA	4	34359	18500
144,1	955	1,8	10,24	S122	160LA	4	22813	6518
135,5	1015	0,9	10,88	S102	160LA	4	16217	4633
134,6	1032	3,3	7,28	S152	180L ⁽²⁾	6	40000	19400
133,9	1037	1,9	7,32	S142	180L ⁽²⁾	6	34940	18500
129,3	1063	2,6	11,41	S142	160LA	4	35000	18500
129,2	1064	1,8	11,42	S122	160LA	4	23364	6675
119,4	1163	1,9	8,21	S142	180L ⁽²⁾	6	35000	18500

⁽²⁾ With TBS brake motor, please contact our Technical Sales Support

15,00 kW

n2 [rpm]	M2 [Nm]	fs	i	Gear reducer	Size	Motor Pole	Fr2 D [N]	Fr2 C-L [N]
118,3	1162	2,8	12,46	S152	160LA	4	40000	19400
117,3	1185	3,1	8,36	S152	180L ⁽²⁾	6	40000	19400
116,8	1177	1,9	12,63	S122	160LA	4	23862	6818
115,5	1202	1,3	8,48	S122	180L ⁽²⁾	6	23871	6820
115,1	1195	2,2	12,81	S142	160LA	4	35000	18500
106,8	1300	3,0	9,17	S152	180L ⁽²⁾	6	40000	19400
106,6	1290	1,9	13,84	S122	160LA	4	24305	6944
106,0	1297	2,8	13,91	S152	160LA	4	40000	19400
105,5	1316	1,9	9,29	S142	180L ⁽²⁾	6	35000	18500
105,4	1304	0,9	13,99	S102	160LA	4	17093	4884
105,4	1318	1,4	9,30	S122	180L ⁽²⁾	6	24308	6945
103,4	1331	1,8	14,27	S142	160LA	4	35000	18500
98,9	1405	1,9	9,91	S142	180L ⁽²⁾	6	35000	18500
95,7	1451	1,2	10,24	S122	180L ⁽²⁾	6	24749	7071
94,1	1477	3,0	10,42	S152	180L ⁽²⁾	6	40000	19400
92,4	1489	2,8	15,97	S152	160LA	4	40000	19400
92,2	1492	1,8	16,01	S142	160LA	4	35000	18500
86,8	1584	1,6	16,99	S122	160LA	4	25237	7211
85,9	1617	1,8	11,41	S142	180L ⁽²⁾	6	35000	18500
85,8	1618	1,2	11,42	S122	180L ⁽²⁾	6	25224	7207
84,2	1634	2,8	17,53	S152	160LA	4	40000	19400
81,5	1688	1,8	18,11	S142	160LA	4	35000	18500
78,6	1766	2,0	12,46	S152	180L ⁽²⁾	6	40000	19400
77,6	1789	1,3	12,63	S122	180L ⁽²⁾	6	25634	7324
76,5	1816	1,5	12,81	S142	180L ⁽²⁾	6	35000	18500
76,3	1803	1,8	19,33	S142	160LA	4	35000	18500
74,1	1856	2,8	19,91	S152	160LA	4	40000	19400
70,8	1961	1,3	13,84	S122	180L ⁽²⁾	6	25979	7423
70,5	1971	2,0	13,91	S152	180L ⁽²⁾	6	40000	19400
69,4	1981	1,4	21,25	S122	160LA	4	26125	7464
68,7	2023	1,3	14,27	S142	180L ⁽²⁾	6	35000	18500
66,3	2074	1,6	22,24	S142	160LA	4	35000	18500
65,9	2085	1,3	22,37	S122	160LA	4	26304	7515
64,5	2133	2,8	22,88	S152	160LA	4	40000	19400
63,3	2172	1,3	23,29	S122	160LA	4	26438	7554
61,4	2263	2,0	15,97	S152	180L ⁽²⁾	6	40000	19400
61,2	2269	1,2	16,01	S142	180L ⁽²⁾	6	35000	18500
58,4	2355	1,2	25,26	S142	160LA	4	35000	18500
57,7	2408	1,1	16,99	S122	180L ⁽²⁾	6	26628	7608
56,4	2438	1,2	26,15	S122	160LA	4	26778	7651
55,9	2484	2,0	17,53	S152	180L ⁽²⁾	6	40000	19400
54,4	2527	2,4	27,11	S152	160LA	4	40000	19400

(2) With TBS brake motor, please contact our Technical Sales Support

15,00 kW

n2 [rpm]	M2 [Nm]	fs	i	Gear reducer	Motor Size	Pole	Fr2 D [N]	Fr2 C-L [N]
54,1	2566	1,2	18,11	S142	180L ⁽²⁾	6	35000	18500
52,1	2642	1,2	28,33	S142	160LA	4	35000	18500
51,6	2666	1,1	28,60	S122	160LA	4	26993	7712
50,7	2740	1,2	19,33	S142	180L ⁽²⁾	6	35000	18500
49,6	2774	2,4	29,75	S152	160LA	4	40000	19400
49,2	2821	2,0	19,91	S152	180L ⁽²⁾	6	40000	19400
48,3	2845	1,1	30,51	S122	160LA	4	27118	7748
46,1	3012	1,0	21,25	S122	180L ⁽²⁾	6	27079	7737
46,0	2988	1,2	32,05	S142	160LA	4	35000	18500
45,0	3054	1,0	32,76	S122	160LA	4	27224	7778
44,1	3118	1,0	33,44	S122	160LA	4	27248	7785
44,1	3153	1,1	22,24	S142	180L ⁽²⁾	6	35000	18500
43,8	3170	0,9	22,37	S122	180L ⁽²⁾	6	27136	7753
43,7	3150	2,4	33,79	S152	160LA	4	40000	19400
43,1	3191	1,2	34,22	S142	160LA	4	35000	18500
42,8	3243	2,0	22,88	S152	180L ⁽²⁾	6	40000	19400
42,1	3301	0,9	23,29	S122	180L ⁽²⁾	6	27166	7762
41,9	3282	0,9	35,20	S122	160LA	4	27293	7798
38,0	3621	2,1	38,84	S152	160LA	4	40000	19400
37,5	3671	1,2	39,38	S142	160LA	4	35000	18500
36,8	3661	1,7	40,10	S153	160LA	4	40000	19400
36,2	3842	1,7	27,11	S152	180L ⁽²⁾	6	40000	19400
33,0	4086	1,7	44,76	S153	160LA	4	40000	19400
32,9	4216	1,7	29,75	S152	180L ⁽²⁾	6	40000	19400
32,2	4178	1,0	45,77	S143	160LA	4	35000	18500
29,0	4789	1,7	33,79	S152	180L ⁽²⁾	6	40000	19400
28,9	4653	1,0	50,97	S143	160LA	4	34794	18500
28,7	4691	1,7	51,38	S153	160LA	4	40000	19400
26,2	5148	1,6	56,39	S153	160LA	4	40000	19400
25,8	5219	0,9	57,17	S143	160LA	4	33091	18500
25,2	5505	1,5	38,84	S152	180L ⁽²⁾	6	40000	19400
24,4	5565	1,2	40,10	S153	180L ⁽²⁾	6	40000	19400
23,0	5847	1,5	64,05	S153	160LA	4	40000	19400
21,9	6211	1,2	44,76	S153	180L ⁽²⁾	6	40000	19400
20,0	6721	1,2	73,63	S153	160LA	4	40000	19400
19,1	7131	1,2	51,38	S153	180L ⁽²⁾	6	40000	19400
17,4	7826	1,1	56,39	S153	180L ⁽²⁾	6	40000	19400
15,3	8889	1,0	64,05	S153	180L ⁽²⁾	6	40000	19400

⁽²⁾ With TBS brake motor, please contact our Technical Sales Support

18,50 kW

n2 [rpm]	M2 [Nm]	fs	i	Gear reducer	Motor Size	Pole	Fr2 D [N]	Fr2 C-L [N]
357,0	475	2,9	4,12	S142	180M ⁽²⁾	4	27453	15687
320,5	529	2,9	4,59	S142	180M ⁽²⁾	4	28156	16089
285,8	593	2,9	5,14	S142	180M ⁽²⁾	4	28897	16513
252,6	671	2,9	5,82	S142	180M ⁽²⁾	4	29677	16958
241,3	710	3,8	4,06	S152	200LA ⁽²⁾	6	39103	19400
238,0	720	2,0	4,12	S142	200LA ⁽²⁾	6	29990	17137
236,6	717	2,9	6,21	S142	180M ⁽²⁾	4	30083	17190
216,2	792	3,8	4,53	S152	200LA ⁽²⁾	6	40000	19400
213,7	802	2,0	4,59	S142	200LA ⁽²⁾	6	30636	17506
201,9	840	3,9	7,28	S152	180M ⁽²⁾	4	40000	19400
200,9	844	2,3	7,32	S142	180M ⁽²⁾	4	31061	17749
190,5	899	2,0	5,14	S142	200LA ⁽²⁾	6	31294	17882
188,3	910	3,4	5,20	S152	200LA ⁽²⁾	6	40000	19400
179,1	947	2,3	8,21	S142	180M ⁽²⁾	4	31707	18118
175,9	964	3,7	8,36	S152	180M ⁽²⁾	4	40000	19400
173,3	979	1,5	8,48	S122	180M ⁽²⁾	4	21158	6045
171,6	998	3,1	5,71	S152	200LA ⁽²⁾	6	40000	19400
168,4	1017	2,0	5,82	S142	200LA ⁽²⁾	6	31957	18261
160,3	1058	3,5	9,17	S152	180M ⁽²⁾	4	40000	19400
158,3	1071	2,3	9,29	S142	180M ⁽²⁾	4	32354	18488
158,1	1073	1,6	9,30	S122	180M ⁽²⁾	4	21566	6162
157,7	1086	2,0	6,21	S142	200LA ⁽²⁾	6	32288	18450
150,2	1140	2,8	6,52	S152	200LA ⁽²⁾	6	40000	19400
148,3	1144	2,3	9,91	S142	180M ⁽²⁾	4	32674	18500
143,6	1181	1,4	10,24	S122	180M ⁽²⁾	4	21983	6281
141,1	1202	3,5	10,42	S152	180M ⁽²⁾	4	40000	19400
134,6	1273	2,7	7,28	S152	200LA ⁽²⁾	6	40000	19400
133,9	1279	1,6	7,32	S142	200LA ⁽²⁾	6	33032	18500
128,9	1316	2,1	11,41	S142	180M ⁽²⁾	4	33291	18500
128,8	1317	1,4	11,42	S122	180M ⁽²⁾	4	22437	6411
119,4	1435	1,6	8,21	S142	200LA ⁽²⁾	6	33470	18500
117,9	1438	2,3	12,46	S152	180M ⁽²⁾	4	40000	19400
117,3	1461	2,5	8,36	S152	200LA ⁽²⁾	6	40000	19400
116,4	1457	1,5	12,63	S122	180M ⁽²⁾	4	22835	6524
115,5	1483	1,1	8,48	S122	200LA ⁽²⁾	6	22809	6517
114,7	1478	1,8	12,81	S142	180M ⁽²⁾	4	33719	18500
106,8	1603	2,5	9,17	S152	200LA ⁽²⁾	6	40000	19400
106,2	1597	1,5	13,84	S122	180M ⁽²⁾	4	23176	6622
105,7	1605	2,3	13,91	S152	180M ⁽²⁾	4	40000	19400
105,5	1623	1,6	9,29	S142	200LA ⁽²⁾	6	33845	18500
105,4	1625	1,1	9,30	S122	200LA ⁽²⁾	6	23143	6612
103,0	1647	1,5	14,27	S142	180M ⁽²⁾	4	34036	18500

(2) With TBS brake motor, please contact our Technical Sales Support

18,50 kW

n2 [rpm]	M2 [Nm]	fs	i	Gear reducer	Motor Size	Pole	Fr2 D [N]	Fr2 C-L [N]
98,9	1733	1,6	9,91	S142	200LA ⁽²⁾	6	33998	18500
95,7	1790	1,0	10,24	S122	200LA ⁽²⁾	6	23467	6705
94,1	1821	2,4	10,42	S152	200LA ⁽²⁾	6	40000	19400
92,1	1842	2,3	15,97	S152	180M ⁽²⁾	4	40000	19400
91,8	1847	1,4	16,01	S142	180M ⁽²⁾	4	34271	18500
86,5	1961	1,3	16,99	S122	180M ⁽²⁾	4	23846	6813
85,9	1994	1,5	11,41	S142	200LA ⁽²⁾	6	34198	18500
85,8	1996	1,0	11,42	S122	200LA ⁽²⁾	6	23794	6798
83,9	2022	2,3	17,53	S152	180M ⁽²⁾	4	40000	19400
81,2	2089	1,4	18,11	S142	180M ⁽²⁾	4	34388	18500
78,6	2179	1,6	12,46	S152	200LA ⁽²⁾	6	40000	19400
77,6	2207	1,0	12,63	S122	200LA ⁽²⁾	6	24052	6872
76,5	2240	1,2	12,81	S142	200LA ⁽²⁾	6	34212	18500
76,0	2231	1,4	19,33	S142	180M ⁽²⁾	4	34384	18500
73,8	2297	2,3	19,91	S152	180M ⁽²⁾	4	40000	19400
70,8	2419	1,0	13,84	S122	200LA ⁽²⁾	6	24245	6927
70,5	2431	1,6	13,91	S152	200LA ⁽²⁾	6	40000	19400
69,2	2452	1,1	21,25	S122	180M ⁽²⁾	4	24380	6966
68,7	2495	1,0	14,27	S142	200LA ⁽²⁾	6	34080	18500
66,1	2567	1,3	22,24	S142	180M ⁽²⁾	4	34198	18500
65,7	2581	1,1	22,37	S122	180M ⁽²⁾	4	24466	6990
64,2	2640	2,3	22,88	S152	180M ⁽²⁾	4	40000	19400
63,1	2687	1,1	23,29	S122	180M ⁽²⁾	4	24523	7006
61,4	2791	1,6	15,97	S152	200LA ⁽²⁾	6	40000	19400
61,2	2798	1,0	16,01	S142	200LA ⁽²⁾	6	33763	18500
58,2	2915	1,0	25,26	S142	180M ⁽²⁾	4	33786	18500
57,7	2970	0,9	16,99	S122	200LA ⁽²⁾	6	24499	7000
56,2	3018	1,0	26,15	S122	180M ⁽²⁾	4	24625	7036
55,9	3064	1,6	17,53	S152	200LA ⁽²⁾	6	40000	19400
54,2	3127	1,9	27,11	S152	180M ⁽²⁾	4	40000	19400
54,1	3165	1,0	18,11	S142	200LA ⁽²⁾	6	33185	18500
51,9	3269	1,0	28,33	S142	180M ⁽²⁾	4	33182	18500
51,4	3300	0,9	28,60	S122	180M ⁽²⁾	4	24635	7039
50,7	3379	1,0	19,33	S142	200LA ⁽²⁾	6	32766	18500
49,4	3433	1,9	29,75	S152	180M ⁽²⁾	4	40000	19400
49,2	3480	1,6	19,91	S152	200LA ⁽²⁾	6	40000	19400
45,9	3698	1,0	32,05	S142	180M ⁽²⁾	4	32248	18427
43,5	3899	1,9	33,79	S152	180M ⁽²⁾	4	40000	19400
43,0	3949	1,0	34,22	S142	180M ⁽²⁾	4	31615	18066
42,8	4000	1,6	22,88	S152	200LA ⁽²⁾	6	40000	19400
37,8	4481	1,7	38,84	S152	180M ⁽²⁾	4	40000	19400
37,3	4543	1,0	39,38	S142	180M ⁽²⁾	4	29900	17085

(2) With TBS brake motor, please contact our Technical Sales Support

18,50 kW

n2 [rpm]	M2 [Nm]	fs	i	Gear reducer	Size	Motor Pole	Fr2 D [N]	Fr2 C-L [N]
36,7	4531	1,4	40,10	S153	180M ⁽²⁾	4	40000	19400
36,2	4738	1,3	27,11	S152	200LA ⁽²⁾	6	40000	19400
32,9	5200	1,3	29,75	S152	200LA ⁽²⁾	6	40000	19400
32,8	5056	1,4	44,76	S153	180M ⁽²⁾	4	40000	19400
29,0	5907	1,3	33,79	S152	200LA ⁽²⁾	6	40000	19400
28,6	5805	1,4	51,38	S153	180M ⁽²⁾	4	40000	19400
26,1	6371	1,3	56,39	S153	180M ⁽²⁾	4	40000	19400
25,2	6789	1,2	38,84	S152	200LA ⁽²⁾	6	40000	19400
22,9	7236	1,2	64,05	S153	180M ⁽²⁾	4	40000	19400
20,0	8318	0,9	73,63	S153	180M ⁽²⁾	4	40000	19400

22,00 kW

n2 [rpm]	M2 [Nm]	fs	i	Gear reducer	Size	Motor Pole	Fr2 D [N]	Fr2 C-L [N]
357,0	565	2,5	4,12	S142	180L ⁽²⁾	4	26744	15282
320,5	629	2,5	4,59	S142	180L ⁽²⁾	4	27367	15638
285,8	706	2,5	5,14	S142	180L ⁽²⁾	4	28011	16007
257,4	784	3,8	5,71	S152	180L ⁽²⁾	4	37840	19400
252,6	798	2,5	5,82	S142	180L ⁽²⁾	4	28676	16386
241,3	844	3,2	4,06	S152	200LB ⁽²⁾	6	38438	19400
238,0	856	1,7	4,12	S142	200LB ⁽²⁾	6	28917	16524
236,6	852	2,5	6,21	S142	180L ⁽²⁾	4	29014	16579
225,4	895	3,4	6,52	S152	180L ⁽²⁾	4	39159	19400
216,2	942	3,2	4,53	S152	200LB ⁽²⁾	6	39526	19400
213,7	953	1,7	4,59	S142	200LB ⁽²⁾	6	29440	16823
201,9	999	3,3	7,28	S152	180L ⁽²⁾	4	40000	19400
200,9	1004	1,9	7,32	S142	180L ⁽²⁾	4	29801	17029
190,5	1069	1,7	5,14	S142	200LB ⁽²⁾	6	29952	17116
188,3	1082	2,8	5,20	S152	200LB ⁽²⁾	6	40000	19400
179,1	1126	1,9	8,21	S142	180L ⁽²⁾	4	30294	17311
175,9	1147	3,1	8,36	S152	180L ⁽²⁾	4	40000	19400
173,3	1164	1,3	8,48	S122	180L ⁽²⁾	4	20457	5845
171,6	1187	2,6	5,71	S152	200LB ⁽²⁾	6	40000	19400
168,4	1210	1,7	5,82	S142	200LB ⁽²⁾	6	30440	17394
160,3	1259	3,0	9,17	S152	180L ⁽²⁾	4	40000	19400
158,3	1274	1,9	9,29	S142	180L ⁽²⁾	4	30756	17575
158,1	1276	1,3	9,30	S122	180L ⁽²⁾	4	20797	5942
157,7	1291	1,7	6,21	S142	200LB ⁽²⁾	6	30668	17524
150,2	1356	2,4	6,52	S152	200LB ⁽²⁾	6	40000	19400
148,3	1360	1,9	9,91	S142	180L ⁽²⁾	4	30967	17696
143,6	1405	1,2	10,24	S122	180L ⁽²⁾	4	21137	6039
141,1	1430	2,9	10,42	S152	180L ⁽²⁾	4	40000	19400

⁽²⁾ With TBS brake motor, please contact our Technical Sales Support

22,00 kW

n2 [rpm]	M2 [Nm]	fs	i	Gear reducer	Motor Size	Pole	Fr2 D [N]	Fr2 C-L [N]
134,6	1513	2,3	7,28	S152	200LB ⁽²⁾	6	40000	19400
133,9	1521	1,3	7,32	S142	200LB ⁽²⁾	6	31124	17785
128,9	1565	1,8	11,41	S142	180L ⁽²⁾	4	31327	17901
128,8	1566	1,2	11,42	S122	180L ⁽²⁾	4	21493	6141
119,4	1706	1,3	8,21	S142	200LB ⁽²⁾	6	31329	17902
117,9	1710	1,9	12,46	S152	180L ⁽²⁾	4	40000	19400
117,3	1737	2,1	8,36	S152	200LB ⁽²⁾	6	40000	19400
116,4	1732	1,3	12,63	S122	180L ⁽²⁾	4	21791	6226
114,7	1758	1,5	12,81	S142	180L ⁽²⁾	4	31514	18008
106,8	1907	2,1	9,17	S152	200LB ⁽²⁾	6	40000	19400
106,2	1899	1,3	13,84	S122	180L ⁽²⁾	4	22032	6295
105,7	1909	1,9	13,91	S152	180L ⁽²⁾	4	40000	19400
105,5	1930	1,3	9,29	S142	200LB ⁽²⁾	6	31423	17956
105,4	1933	0,9	9,30	S122	200LB ⁽²⁾	6	21978	6279
103,0	1958	1,2	14,27	S142	180L ⁽²⁾	4	31579	18045
98,9	2061	1,3	9,91	S142	200LB ⁽²⁾	6	31412	17950
94,1	2166	2,0	10,42	S152	200LB ⁽²⁾	6	40000	19400
92,1	2191	1,9	15,97	S152	180L ⁽²⁾	4	40000	19400
91,8	2196	1,2	16,01	S142	180L ⁽²⁾	4	31516	18009
86,5	2332	1,1	16,99	S122	180L ⁽²⁾	4	22441	6412
85,9	2371	1,2	11,41	S142	200LB ⁽²⁾	6	31223	17842
83,9	2405	1,9	17,53	S152	180L ⁽²⁾	4	40000	19400
81,2	2485	1,2	18,11	S142	180L ⁽²⁾	4	31271	17869
78,6	2591	1,3	12,46	S152	200LB ⁽²⁾	6	40000	19400
76,5	2663	1,0	12,81	S142	200LB ⁽²⁾	6	30870	17640
76,0	2653	1,2	19,33	S142	180L ⁽²⁾	4	31056	17746
73,8	2731	1,9	19,91	S152	180L ⁽²⁾	4	40000	19400
70,5	2891	1,3	13,91	S152	200LB ⁽²⁾	6	40000	19400
69,2	2916	1,0	21,25	S122	180L ⁽²⁾	4	22623	6464
66,1	3052	1,1	22,24	S142	180L ⁽²⁾	4	30369	17354
65,7	3069	0,9	22,37	S122	180L ⁽²⁾	4	22616	6462
64,2	3140	1,9	22,88	S152	180L ⁽²⁾	4	40000	19400
63,1	3196	0,9	23,29	S122	180L ⁽²⁾	4	22597	6456
61,4	3319	1,3	15,97	S152	200LB ⁽²⁾	6	40000	19400
55,9	3643	1,3	17,53	S152	200LB ⁽²⁾	6	40000	19400
54,2	3719	1,6	27,11	S152	180L ⁽²⁾	4	40000	19400
49,4	4082	1,6	29,75	S152	180L ⁽²⁾	4	40000	19400
49,2	4138	1,3	19,91	S152	200LB ⁽²⁾	6	40000	19400
43,5	4636	1,6	33,79	S152	180L ⁽²⁾	4	40000	19400
42,8	4756	1,3	22,88	S152	200LB ⁽²⁾	6	40000	19400
37,8	5329	1,4	38,84	S152	180L ⁽²⁾	4	40000	19400
36,7	5388	1,2	40,10	S153	180L ⁽²⁾	4	40000	19400

(2) With TBS brake motor, please contact our Technical Sales Support

22,00 kW

n2 [rpm]	M2 [Nm]	fs	i	Gear reducer	Size	Motor Pole	Fr2 D [N]	Fr2 C-L [N]
36,2	5634	1,1	27,11	S152	200LB ⁽²⁾	6	40000	19400
32,9	6184	1,1	29,75	S152	200LB ⁽²⁾	6	40000	19400
32,8	6013	1,2	44,76	S153	180L ⁽²⁾	4	40000	19400
29,0	7024	1,1	33,79	S152	200LB ⁽²⁾	6	40000	19400
28,6	6903	1,1	51,38	S153	180L ⁽²⁾	4	40000	19400
26,1	7577	1,1	56,39	S153	180L ⁽²⁾	4	40000	19400
25,2	8074	1,0	38,84	S152	200LB ⁽²⁾	6	40000	19400
22,9	8605	1,0	64,05	S153	180L ⁽²⁾	4	40000	19400

30,00 kW

n2 [rpm]	M2 [Nm]	fs	i	Gear reducer	Size	Motor Pole	Fr2 D [N]	Fr2 C-L [N]
363,2	757	3,4	4,06	S152	200L ⁽²⁾	4	33490	19137
358,2	768	1,8	4,12	S142	200L ⁽²⁾	4	25110	14348
325,4	845	3,4	4,53	S152	200L ⁽²⁾	4	34429	19400
321,6	855	1,8	4,59	S142	200L ⁽²⁾	4	25549	14600
286,8	959	1,8	5,14	S142	200L ⁽²⁾	4	25976	14843
283,4	970	3,0	5,20	S152	200L ⁽²⁾	4	35610	19400
258,2	1065	2,8	5,71	S152	200L ⁽²⁾	4	36402	19400
253,5	1085	1,8	5,82	S142	200L ⁽²⁾	4	26376	15072
237,4	1159	1,8	6,21	S142	200L ⁽²⁾	4	26560	15177
226,1	1216	2,5	6,52	S152	200L ⁽²⁾	4	37521	19400
202,6	1358	2,4	7,28	S152	200L ⁽²⁾	4	38430	19400
201,6	1365	1,4	7,32	S142	200L ⁽²⁾	4	26916	15381
179,7	1530	1,4	8,21	S142	200L ⁽²⁾	4	27062	15464
176,5	1558	2,3	8,36	S152	200L ⁽²⁾	4	39540	19400
173,9	1582	0,9	8,48	S122	200L ⁽²⁾	4	18846	5385
160,8	1710	2,2	9,17	S152	200L ⁽²⁾	4	40000	19400
158,9	1731	1,4	9,29	S142	200L ⁽²⁾	4	27103	15488
158,6	1734	1,0	9,30	S122	200L ⁽²⁾	4	19034	5438
148,8	1849	1,4	9,91	S142	200L ⁽²⁾	4	27070	15468
141,6	1943	2,2	10,42	S152	200L ⁽²⁾	4	40000	19400
129,3	2127	1,3	11,41	S142	200L ⁽²⁾	4	26847	15341
118,3	2324	1,4	12,46	S152	200L ⁽²⁾	4	40000	19400
116,8	2354	0,9	12,63	S122	200L ⁽²⁾	4	19403	5544
115,1	2389	1,1	12,81	S142	200L ⁽²⁾	4	26486	15135
106,6	2581	0,9	13,84	S122	200L ⁽²⁾	4	19417	5548
106,0	2594	1,4	13,91	S152	200L ⁽²⁾	4	40000	19400
103,4	2661	0,9	14,27	S142	200L ⁽²⁾	4	25983	14847
92,4	2978	1,4	15,97	S152	200L ⁽²⁾	4	40000	19400
84,2	3268	1,4	17,53	S152	200L ⁽²⁾	4	40000	19400
74,1	3712	1,4	19,91	S152	200L ⁽²⁾	4	40000	19400

⁽²⁾ With TBS brake motor, please contact our Technical Sales Support

30,00 kW

n2 [rpm]	M2 [Nm]	fs	i	Gear reducer	Size	Motor	Pole	Fr2 D [N]	Fr2 C-L [N]
64,5	4267	1,4	22,88	S152	200L ⁽²⁾		4	40000	19400
54,4	5054	1,2	27,11	S152	200L ⁽²⁾		4	40000	19400
49,6	5547	1,2	29,75	S152	200L ⁽²⁾		4	40000	19400
43,7	6301	1,2	33,79	S152	200L ⁽²⁾		4	40000	19400
38,0	7242	1,1	38,84	S152	200L ⁽²⁾		4	40000	19400

37,00 kW

n2 [rpm]	M2 [Nm]	fs	i	Gear reducer	Size	Motor	Pole	Fr2 D [N]	Fr2 C-L [N]
365,6	928	2,8	4,06	S152	225S ⁽²⁾		4	32564	18608
327,6	1035	2,8	4,53	S152	225S ⁽²⁾		4	33402	19087
285,4	1189	2,5	5,20	S152	225S ⁽²⁾		4	34440	19400
260,0	1305	2,3	5,71	S152	225S ⁽²⁾		4	35124	19400
227,7	1490	2,1	6,52	S152	225S ⁽²⁾		4	36070	19400
204,0	1663	2,0	7,28	S152	225S ⁽²⁾		4	36818	19400
177,7	1909	1,8	8,36	S152	225S ⁽²⁾		4	37700	19400
161,9	2095	1,8	9,17	S152	225S ⁽²⁾		4	38249	19400
142,5	2380	1,8	10,42	S152	225S ⁽²⁾		4	38928	19400
119,2	2847	1,2	12,46	S152	225S ⁽²⁾		4	39707	19400
106,8	3177	1,2	13,91	S152	225S ⁽²⁾		4	40000	19400
93,0	3648	1,2	15,97	S152	225S ⁽²⁾		4	40000	19400
84,7	4004	1,2	17,53	S152	225S ⁽²⁾		4	40000	19400
74,6	4547	1,2	19,91	S152	225S ⁽²⁾		4	40000	19400
64,9	5227	1,2	22,88	S152	225S ⁽²⁾		4	39878	19400
54,8	6192	1,0	27,11	S152	225S ⁽²⁾		4	38885	19400
49,9	6796	1,0	29,75	S152	225S ⁽²⁾		4	38066	19400
43,9	7719	1,0	33,79	S152	225S ⁽²⁾		4	36577	19400

45,00 kW

n2 [rpm]	M2 [Nm]	fs	i	Gear reducer	Size	Motor	Pole	Fr2 D [N]	Fr2 C-L [N]
365,6	1128	2,3	4,06	S152	225M ⁽²⁾		4	31572	18041
327,6	1259	2,3	4,53	S152	225M ⁽²⁾		4	32295	18454
285,4	1446	2,0	5,20	S152	225M ⁽²⁾		4	33169	18953
260,0	1587	1,9	5,71	S152	225M ⁽²⁾		4	33729	19274
227,7	1812	1,7	6,52	S152	225M ⁽²⁾		4	34477	19400
204,0	2023	1,6	7,28	S152	225M ⁽²⁾		4	35040	19400
177,7	2322	1,5	8,36	S152	225M ⁽²⁾		4	35658	19400
161,9	2548	1,5	9,17	S152	225M ⁽²⁾		4	36009	19400
142,5	2895	1,4	10,42	S152	225M ⁽²⁾		4	36383	19400
119,2	3462	1,0	12,46	S152	225M ⁽²⁾		4	36662	19400

⁽²⁾ With TBS brake motor, please contact our Technical Sales Support

45,00 kW

n2 [rpm]	M2 [Nm]	fs	i	Gear reducer	Size	Motor Pole	Fr2 D [N]	Fr2 C-L [N]
106,8	3864	1,0	13,91	S152	225M ⁽²⁾	4	36660	19400
93,0	4436	1,0	15,97	S152	225M ⁽²⁾	4	36430	19400
84,7	4869	1,0	17,53	S152	225M ⁽²⁾	4	36110	19400
74,6	5530	1,0	19,91	S152	225M ⁽²⁾	4	35423	19400
64,9	6357	1,0	22,88	S152	225M ⁽²⁾	4	34288	19400

⁽²⁾ With TBS brake motor, please contact our Technical Sales Support

IS052

Mn ₂ [Nm]	i	Pn ₁ [kW]	n ₂ [rpm]	Fr1 [N]	Fr2 D [N]	Fr2 C-L [N]
160	8,63	3,54	202,9	759	3125	3125
179	11,14	3,06	157,1	846	3373	3373
188	12,00	2,99	145,8	859	3428	3428
197	13,66	2,76	128,2	901	3570	3570
226	15,27	2,82	114,6	890	3584	3584
226	16,29	2,64	107,5	922	3689	3689
226	18,63	2,31	93,9	983	3916	3916
226	19,73	2,18	88,7	1007	4015	4015
244	21,04	2,22	83,2	1000	4020	4020
244	21,53	2,17	81,3	1010	4062	4062
244	24,07	1,94	72,7	1051	4267	4267
273	25,20	2,06	69,4	1028	4190	4190
273	25,79	2,02	67,9	1037	4234	4234
273	27,81	1,87	62,9	1064	4381	4381
273	30,00	1,73	58,3	1089	4532	4532
282	32,55	1,65	53,8	1104	4644	4644
282	33,00	1,63	53,0	1108	4673	4673
282	34,09	1,58	51,3	1117	4741	4741
310	36,55	1,62	47,9	1110	4725	4725
310	38,75	1,53	45,2	1127	4853	4853
329	39,90	1,57	43,9	1118	4808	4808
329	42,63	1,47	41,1	1137	4956	4956
329	46,00	1,37	38,0	1156	5131	5131
329	47,20	1,33	37,1	1163	5191	5191
329	52,25	1,20	33,5	1186	5433	5433
329	57,86	1,09	30,2	1208	5685	5685
329	59,42	1,06	29,4	1213	5752	5752
329	72,83	0,86	24,0	1249	6000	6000

IS053

Mn ₂ [Nm]	i	Pn ₁ [kW]	n ₂ [rpm]	Fr1 [N]	Fr2 D [N]	Fr2 C-L [N]
329	36,50	1,76	48,0	1091	4613	4613
329	47,14	1,36	37,1	1162	5188	5188
329	57,79	1,11	30,3	1207	5682	5682
329	63,74	1,01	27,4	1226	5931	5931
329	74,20	0,86	23,6	1251	6000	6000
329	78,14	0,82	22,4	1259	6000	6000
329	95,84	0,67	18,3	1286	6000	6000
329	117,48	0,55	14,9	1309	6000	6000
329	137,45	0,47	12,7	1323	6000	6000
329	177,55	0,36	9,9	1342	6000	6000

IS053

Mn ₂ [Nm]	i	Pn ₁ [kW]	n ₂ [rpm]	Fr1 [N]	Fr2 D [N]	Fr2 C-L [N]
329	198,45	0,32	8,8	1348	6000	6000
329	217,64	0,29	8,0	1354	6000	6000
329	256,33	0,25	6,8	1362	6000	6000
329	314,21	0,20	5,6	1370	6000	6000

IS062

Mn ₂ [Nm]	i	Pn ₁ [kW]	n ₂ [rpm]	Fr1 [N]	Fr2 D [N]	Fr2 C-L [N]
310	8,00	7,40	218,8	413	4832	1933
310	8,92	6,64	196,2	516	5081	2032
338	9,55	6,77	183,3	499	5061	2024
338	10,65	6,07	164,4	593	5325	2130
367	11,71	5,98	149,5	605	5385	2154
395	13,06	5,77	134,0	633	5488	2195
395	13,36	5,64	131,0	650	5548	2219
423	15,94	5,07	109,8	727	5853	2341
423	16,16	5,00	108,3	737	5892	2357
423	19,29	4,19	90,7	846	6407	2563
432	19,55	4,22	89,5	841	6388	2555
442	23,18	3,64	75,5	920	6856	2742
442	23,75	3,55	73,7	931	6934	2774
451	25,14	3,43	69,6	948	7059	2824
451	27,66	3,11	63,3	990	7376	2950
470	30,00	2,99	58,3	1007	7536	3014
508	33,93	2,86	51,6	1025	7733	3093
564	36,57	2,94	47,9	1013	7650	3060
564	39,38	2,73	44,4	1041	7927	3171
564	43,64	2,47	40,1	1077	8324	3329
564	46,10	2,34	38,0	1095	8541	3416
564	48,30	2,23	36,2	1109	8729	3492
564	53,53	2,01	32,7	1138	9154	3661
564	55,00	1,96	31,8	1146	9268	3707
564	67,47	1,60	25,9	1194	10000	4000

IS063

Mn ₂ [Nm]	i	Pn ₁ [kW]	n ₂ [rpm]	Fr1 [N]	Fr2 D [N]	Fr2 C-L [N]
564	33,57	3,28	52,1	978	7337	2935
564	37,77	2,91	46,3	1026	7770	3108
564	40,05	2,74	43,7	1047	7992	3197
564	49,13	2,24	35,6	1114	8799	3519

IS063

Mn_2 [Nm]	i	Pn_1 [kW]	n2 [rpm]	Fr1 [N]	Fr2 D [N]	Fr2 C-L [N]
564	55,29	1,99	31,6	1147	9290	3716
564	58,72	1,87	29,8	1162	9548	3819
564	65,85	1,67	26,6	1189	10000	4000
564	68,25	1,61	25,6	1197	10000	4000
564	73,63	1,49	23,8	1212	10000	4000
564	81,43	1,35	21,5	1231	10000	4000
564	99,89	1,10	17,5	1264	10000	4000
564	126,43	0,87	13,8	1294	10000	4000
564	150,85	0,73	11,6	1313	10000	4000
564	182,53	0,60	9,6	1330	10000	4000
564	185,05	0,59	9,5	1331	10000	4000
564	217,79	0,50	8,0	1342	10000	4000
564	267,16	0,41	6,5	1355	10000	4000

IS082

Mn_2 [Nm]	i	Pn_1 [kW]	n2 [rpm]	Fr1 [N]	Fr2 D [N]	Fr2 C-L [N]
517	7,34	13,45	238,4	1365	11156	3188
564	8,06	13,35	217,1	1376	11407	3259
611	9,94	11,73	176,0	1572	12203	3487
658	11,61	10,82	150,8	1681	12792	3655
705	12,75	10,55	137,2	1714	13109	3745
714	14,04	9,71	124,6	1816	13578	3879
724	15,43	8,95	113,4	1907	14049	4014
724	15,73	8,79	111,3	1927	14153	4044
724	17,29	7,99	101,2	2023	14680	4194
724	19,03	7,26	92,0	2111	15226	4350
724	20,14	6,86	86,9	2159	15559	4445
752	22,13	6,49	79,1	2204	16032	4580
752	24,00	5,98	72,9	2265	16535	4724
752	26,05	5,51	67,2	2322	17056	4873
846	27,29	5,92	64,1	2273	17049	4871
846	28,67	5,63	61,0	2308	17375	4964
846	29,60	5,46	59,1	2329	17588	5025
940	31,78	5,65	55,1	2306	17762	5075
940	34,91	5,14	50,1	2367	18000	5263
940	35,50	5,05	49,3	2377	18000	5297
940	40,05	4,48	43,7	2447	18000	5548
940	43,05	4,17	40,6	2484	18000	5703
940	50,25	3,57	34,8	2556	18000	6047
940	54,27	3,31	32,2	2588	18000	6226
940	61,98	2,90	28,2	2638	18000	6544

IS083

Mn ₂ [Nm]	i	Pn ₁ [kW]	n ₂ [rpm]	Fr1 [N]	Fr2 D [N]	Fr2 C-L [N]
940	67,52	2,71	25,9	2667	18000	6757
940	74,18	2,47	23,6	2695	18000	6998
940	81,71	2,24	21,4	2722	18000	7200
940	91,49	2,00	19,1	2750	18000	7200
940	100,62	1,82	17,4	2772	18000	7200
940	117,17	1,56	14,9	2802	18000	7200
940	128,73	1,42	13,6	2819	18000	7200
940	136,34	1,34	12,8	2828	18000	7200
940	158,76	1,15	11,0	2851	18000	7200
940	184,88	0,99	9,5	2870	18000	7200
940	203,11	0,90	8,6	2881	18000	7200
940	205,34	0,89	8,5	2882	18000	7200
940	226,04	0,81	7,7	2891	18000	7200
940	250,50	0,73	7,0	2901	18000	7200
940	266,13	0,69	6,6	2906	18000	7200
940	292,36	0,63	6,0	2913	18000	7200
940	315,73	0,58	5,5	2919	18000	7200
940	360,58	0,51	4,8	2927	18000	7200

IS102

Mn ₂ [Nm]	i	Pn ₁ [kW]	n ₂ [rpm]	Fr1 [N]	Fr2 D [N]	Fr2 C-L [N]
799	8,06	18,92	217,1	788	14063	4018
846	8,85	18,25	197,8	865	14442	4126
893	10,88	15,66	160,8	1166	15499	4428
940	12,75	14,07	137,2	1351	16332	4666
1128	13,99	15,39	125,1	1198	16427	4694
1175	15,43	14,54	113,4	1297	16941	4840
1222	17,21	13,55	101,7	1412	17554	5015
1316	19,00	13,22	92,1	1450	17997	5142
1316	20,83	12,06	84,0	1585	18656	5330
1316	22,13	11,35	79,1	1668	19100	5457
1410	24,28	11,09	72,1	1699	19556	5588
1410	26,33	10,22	66,5	1800	20188	5768
1410	29,87	9,01	58,6	1940	21200	6057
1410	32,40	8,31	54,0	2022	21877	6250
1316	34,91	7,20	50,1	2152	22000	6502
1410	38,30	7,03	45,7	2171	22000	6665
1316	42,53	5,91	41,1	2301	22000	7005
1222	44,00	5,30	39,8	2372	22000	7165
1504	47,13	6,09	37,1	2280	22000	7141
1316	50,25	5,00	34,8	2407	22000	7457

IS102

Mn ₂ [Nm]	i	Pn ₁ [kW]	n ₂ [rpm]	Fr1 [N]	Fr2 D [N]	Fr2 C-L [N]
1222	55,14	4,23	31,7	2497	22000	7789
1504	59,40	4,83	29,5	2426	22000	7796
1504	67,84	4,23	25,8	2496	22000	8196

IS103

Mn ₂ [Nm]	i	Pn ₁ [kW]	n ₂ [rpm]	Fr1 [N]	Fr2 D [N]	Fr2 C-L [N]
1504	74,18	3,95	23,6	2539	22000	8474
1504	81,39	3,60	21,5	2578	22000	8773
1504	89,77	3,27	19,5	2617	22000	9000
1504	100,15	2,93	17,5	2655	22000	9000
1504	110,55	2,65	15,8	2687	22000	9000
1504	121,29	2,42	14,4	2713	22000	9000
1504	128,73	2,28	13,6	2729	22000	9000
1504	141,24	2,08	12,4	2752	22000	9000
1504	173,78	1,69	10,1	2797	22000	9000
1504	188,51	1,56	9,3	2812	22000	9000
1504	203,11	1,44	8,6	2824	22000	9000
1504	222,85	1,32	7,8	2839	22000	9000
1504	224,76	1,30	7,8	2840	22000	9000
1504	274,20	1,07	6,4	2867	22000	9000
1504	280,89	1,04	6,2	2870	22000	9000
1504	292,36	1,00	6,0	2875	22000	9000
1504	320,79	0,91	5,5	2885	22000	9000
1504	345,60	0,85	5,1	2892	22000	9000
1504	394,69	0,74	4,4	2904	22000	9000

IS122

Mn ₂ [Nm]	i	Pn ₁ [kW]	n ₂ [rpm]	Fr1 [N]	Fr2 D [N]	Fr2 C-L [N]
1410	8,48	31,73	206,3	3012	18134	5181
1598	9,30	32,81	188,2	2979	18143	5184
1598	10,24	29,79	170,9	3070	18925	5407
1786	11,42	29,86	153,3	3068	19127	5465
2068	12,63	31,26	138,6	3026	18934	5410
2256	13,84	31,12	126,5	3030	19045	5441
2444	16,99	27,45	103,0	3140	20267	5791
2632	21,25	23,64	82,3	3255	21815	6233
2632	22,37	22,46	78,2	3290	22357	6388
2726	23,29	22,34	75,1	3294	22436	6410
2820	26,15	20,58	66,9	3347	23357	6674

IS122

Mn ₂ [Nm]	i	Pn ₁ [kW]	n ₂ [rpm]	Fr1 [N]	Fr2 D [N]	Fr2 C-L [N]
2820	28,60	18,82	61,2	3400	24377	6965
2820	30,51	17,64	57,4	3435	25134	7181
2820	32,76	16,43	53,4	3471	25982	7423
2820	33,44	16,09	52,3	3482	26235	7496
2820	35,20	15,29	49,7	3506	26863	7675
2820	41,07	13,11	42,6	3571	28822	8235
2820	43,60	12,35	40,1	3594	29610	8460
2256	44,63	9,65	39,2	3675	30000	9160
2256	49,04	8,78	35,7	3702	30000	9526
2444	53,75	8,68	32,6	3705	30000	9690
2820	66,00	8,16	26,5	3720	30000	10148

IS123

Mn ₂ [Nm]	i	Pn ₁ [kW]	n ₂ [rpm]	Fr1 [N]	Fr2 D [N]	Fr2 C-L [N]
2538	64,84	7,63	27,0	3741	30000	10376
2538	71,07	6,96	24,6	3761	30000	10780
2820	78,46	7,01	22,3	3759	30000	10923
2820	87,27	6,30	20,1	3780	30000	11200
2820	105,91	5,19	16,5	3813	30000	11200
2820	112,52	4,89	15,6	3822	30000	11200
2820	123,33	4,46	14,2	3834	30000	11200
2820	130,04	4,23	13,5	3841	30000	11200
2820	133,78	4,11	13,1	3845	30000	11200
2820	151,43	3,63	11,6	3859	30000	11200
2820	177,53	3,10	9,9	3874	30000	11200
2820	194,59	2,83	9,0	3882	30000	11200
2820	215,60	2,55	8,1	3890	30000	11200
2820	238,93	2,30	7,3	3898	30000	11200

IS142

Mn ₂ [Nm]	i	Pn ₁ [kW]	n ₂ [rpm]	Fr1 [N]	Fr2 D [N]	Fr2 C-L [N]
1306	4,12	60,53	425,0	2548	19159	10948
1455	4,59	60,57	381,6	2546	19045	10883
1633	5,14	60,61	340,2	2545	18820	10754
1846	5,82	60,56	300,7	2547	18458	10548
1973	6,21	60,62	281,7	2545	18177	10387
1801	7,32	46,97	239,2	3073	21411	12235
2020	8,21	46,97	213,2	3073	21057	12033
2286	9,29	46,99	188,5	3073	20496	11712

IS142

Mn_2 [Nm]	i	Pn_1 [kW]	n2 [rpm]	Fr1 [N]	Fr2 D [N]	Fr2 C-L [N]
2441	9,91	47,00	176,5	3072	20113	11493
2647	11,41	44,30	153,4	3177	20353	11630
2463	12,81	36,69	136,6	3471	23418	13382
2294	14,27	30,68	122,6	3704	26304	15031
2493	16,01	29,73	109,3	3741	26448	15113
2820	18,11	29,73	96,6	3741	25783	14733
3011	19,33	29,73	90,5	3741	25321	14469
3116	22,24	26,74	78,7	3857	26820	15326
2722	25,26	20,57	69,3	4096	32131	18360
3053	28,33	20,57	61,8	4096	31591	18052
3454	32,05	20,57	54,6	4096	30742	17567
3688	34,22	20,57	51,1	4096	30165	17237
4165	39,38	20,19	44,4	4111	29206	16689

IS143

Mn_2 [Nm]	i	Pn_1 [kW]	n2 [rpm]	Fr1 [N]	Fr2 D [N]	Fr2 C-L [N]
3772	45,77	16,07	38,2	4200	35000	18500
4202	50,97	16,07	34,3	4200	34436	18500
4450	57,17	15,17	30,6	4200	35000	18500
4488	64,68	13,53	27,1	4200	35000	18500
4584	69,06	12,94	25,3	4200	35000	18500
3979	79,45	9,76	22,0	4200	35000	18500
4174	98,81	8,23	17,7	4200	35000	18500
4450	110,05	7,88	15,9	4200	35000	18500
4469	123,44	7,06	14,2	4200	35000	18500
4550	139,64	6,35	12,5	4200	35000	18500
4499	149,10	5,88	11,7	4200	35000	18500
3573	157,49	4,42	11,1	4200	35000	18500
4389	171,55	4,99	10,2	4200	35000	18500
3980	175,41	4,42	10,0	4200	35000	18500
4464	196,74	4,42	8,9	4200	35000	18500
4432	222,57	3,88	7,9	4200	35000	18500
4589	237,63	3,76	7,4	4200	35000	18500
4504	273,41	3,21	6,4	4200	35000	18500

IS152

Mn_2 [Nm]	i	Pn_1 [kW]	n2 [rpm]	Fr1 [N]	Fr2 D [N]	Fr2 C-L [N]
2419	4,06	113,68	430,9	2971	23230	13274
2699	4,53	113,65	386,1	2972	23144	13225

IS152

Mn ₂ [Nm]	i	Pn ₁ [kW]	n ₂ [rpm]	Fr1 [N]	Fr2 D [N]	Fr2 C-L [N]
2739	5,20	100,47	336,3	3282	24645	14083
2765	5,71	92,42	306,4	3471	25706	14689
2891	6,52	84,58	268,3	3656	26853	15345
3063	7,28	80,32	240,4	3756	27516	15724
3319	8,36	75,81	209,4	3862	28240	16137
3526	9,17	73,37	190,8	3919	28610	16349
3931	10,42	72,02	168,0	3951	28583	16333
3107	12,46	47,59	140,4	4525	35582	19400
3467	13,91	47,57	125,8	4526	35686	19400
3980	15,97	47,58	109,6	4526	35607	19400
4369	17,53	47,59	99,8	4525	35408	19400
4963	19,91	47,59	87,9	4525	34919	19400
5706	22,88	47,60	76,5	4525	34041	19400
5724	27,11	40,31	64,6	4697	37532	19400
6284	29,75	40,32	58,8	4696	36818	19400
7137	33,79	40,32	51,8	4696	35512	19400
7228	38,84	35,52	45,1	4809	38394	19400

IS153

Mn ₂ [Nm]	i	Pn ₁ [kW]	n ₂ [rpm]	Fr1 [N]	Fr2 D [N]	Fr2 C-L [N]
5905	40,10	28,70	43,6	4984	40000	19400
6589	44,76	28,70	39,1	4984	40000	19400
7393	51,38	28,05	34,1	4999	40000	19400
7759	56,39	26,82	31,0	5027	40000	19400
8268	64,05	25,16	27,3	5065	40000	19400
7313	73,63	19,36	23,8	5199	40000	19400
6679	87,16	14,94	20,1	5200	40000	19400
7455	97,27	14,94	18,0	5200	40000	19400
8558	111,67	14,94	15,7	5200	40000	19400
8964	122,57	14,26	14,3	5200	40000	19400
8593	139,21	12,03	12,6	5200	40000	19400
6701	154,02	8,48	11,4	5200	40000	19400
7599	160,02	9,26	10,9	5200	40000	19400
7693	176,81	8,48	9,9	5200	40000	19400
8443	194,06	8,48	9,0	5200	40000	19400
8792	220,42	7,78	7,9	5200	40000	19400
7782	253,36	5,99	6,9	5200	40000	19400

IS052

Mn ₂ [Nm]	i	Pn ₁ [kW]	n ₂ [rpm]	Fr1 [N]	Fr2 D [N]	Fr2 C-L [N]
170	8,63	3,01	162,3	718	3375	3375
190	11,14	2,60	125,7	810	3644	3644
200	12,00	2,55	116,7	824	3703	3703
210	13,66	2,35	102,5	869	3857	3857
240	15,27	2,40	91,7	857	3874	3874
240	16,29	2,25	86,0	891	3987	3987
240	18,63	1,97	75,1	956	4231	4231
240	19,73	1,86	71,0	981	4338	4338
260	21,04	1,89	66,5	974	4345	4345
260	21,53	1,84	65,0	984	4390	4390
260	24,07	1,65	58,2	1029	4611	4611
290	25,20	1,76	55,6	1004	4530	4530
290	25,79	1,72	54,3	1013	4578	4578
290	27,81	1,59	50,3	1042	4736	4736
290	30,00	1,48	46,7	1069	4898	4898
300	32,55	1,41	43,0	1084	5020	5020
300	33,00	1,39	42,4	1089	5051	5051
300	34,09	1,34	41,1	1099	5124	5124
330	36,55	1,38	38,3	1091	5109	5109
330	38,75	1,30	36,1	1109	5246	5246
350	39,90	1,34	35,1	1100	5200	5200
350	42,63	1,25	32,8	1119	5359	5359
350	46,00	1,16	30,4	1140	5547	5547
350	47,20	1,13	29,7	1147	5612	5612
350	52,25	1,02	26,8	1172	5873	5873
350	57,86	0,92	24,2	1195	6000	6000
350	59,42	0,90	23,6	1201	6000	6000
350	72,83	0,73	19,2	1238	6000	6000

IS053

Mn ₂ [Nm]	i	Pn ₁ [kW]	n ₂ [rpm]	Fr1 [N]	Fr2 D [N]	Fr2 C-L [N]
350	36,50	1,50	38,4	1071	4990	4990
350	47,14	1,16	29,7	1147	5609	5609
350	57,79	0,94	24,2	1195	6000	6000
350	63,74	0,86	22,0	1214	6000	6000
350	74,20	0,74	18,9	1242	6000	6000
350	78,14	0,70	17,9	1250	6000	6000
350	95,84	0,57	14,6	1279	6000	6000
350	117,48	0,46	11,9	1302	6000	6000
350	137,45	0,40	10,2	1317	6000	6000
350	177,55	0,31	7,9	1338	6000	6000

IS053

Mn ₂ [Nm]	i	Pn ₁ [kW]	n ₂ [rpm]	Fr1 [N]	Fr2 D [N]	Fr2 C-L [N]
350	198,45	0,28	7,0	1345	6000	6000
350	217,64	0,25	6,4	1350	6000	6000
350	256,33	0,21	5,5	1359	6000	6000
350	314,21	0,17	4,5	1367	6000	6000

IS062

Mn ₂ [Nm]	i	Pn ₁ [kW]	n ₂ [rpm]	Fr1 [N]	Fr2 D [N]	Fr2 C-L [N]
330	8,00	6,30	175,0	350	5225	2090
330	8,92	5,65	156,9	459	5494	2197
360	9,55	5,76	146,7	441	5474	2190
360	10,65	5,16	131,5	541	5759	2303
390	11,71	5,09	119,6	554	5825	2330
420	13,06	4,91	107,2	583	5939	2376
420	13,36	4,80	104,8	602	6004	2401
450	15,94	4,31	87,8	684	6334	2533
450	16,16	4,25	86,6	694	6376	2551
450	19,29	3,56	72,6	810	6930	2772
460	19,55	3,59	71,6	805	6911	2764
470	23,18	3,10	60,4	888	7415	2966
470	23,75	3,02	59,0	901	7499	3000
480	25,14	2,92	55,7	919	7635	3054
480	27,66	2,65	50,6	963	7976	3190
500	30,00	2,55	46,7	981	8149	3260
540	33,93	2,43	41,3	1000	8364	3346
600	36,57	2,51	38,3	988	8280	3312
600	39,38	2,33	35,6	1018	8578	3431
600	43,64	2,10	32,1	1056	9005	3602
600	46,10	1,99	30,4	1075	9239	3695
600	48,30	1,90	29,0	1090	9441	3776
600	53,53	1,71	26,1	1121	9898	3959
600	55,00	1,67	25,4	1129	10000	4000
600	67,47	1,36	20,8	1181	10000	4000

IS063

Mn ₂ [Nm]	i	Pn ₁ [kW]	n ₂ [rpm]	Fr1 [N]	Fr2 D [N]	Fr2 C-L [N]
600	33,57	2,79	41,7	950	7943	3177
600	37,77	2,48	37,1	1001	8409	3364
600	40,05	2,34	35,0	1024	8648	3459
600	49,13	1,90	28,5	1095	9516	3806

IS063

Mn ₂ [Nm]	i	Pn ₁ [kW]	n ₂ [rpm]	Fr1 [N]	Fr2 D [N]	Fr2 C-L [N]
600	55,29	1,69	25,3	1130	10000	4000
600	58,72	1,59	23,8	1147	10000	4000
600	65,85	1,42	21,3	1175	10000	4000
600	68,25	1,37	20,5	1183	10000	4000
600	73,63	1,27	19,0	1200	10000	4000
600	81,43	1,15	17,2	1220	10000	4000
600	99,89	0,94	14,0	1255	10000	4000
600	126,43	0,74	11,1	1287	10000	4000
600	150,85	0,62	9,3	1307	10000	4000
600	182,53	0,51	7,7	1324	10000	4000
600	185,05	0,51	7,6	1326	10000	4000
600	217,79	0,43	6,4	1338	10000	4000
600	267,16	0,35	5,2	1351	10000	4000

IS082

Mn ₂ [Nm]	i	Pn ₁ [kW]	n ₂ [rpm]	Fr1 [N]	Fr2 D [N]	Fr2 C-L [N]
550	7,34	11,44	190,8	1261	12030	3437
600	8,06	11,36	173,6	1273	12302	3515
650	9,94	9,98	140,8	1482	13161	3760
700	11,61	9,21	120,6	1598	13797	3942
750	12,75	8,98	109,8	1632	14140	4040
760	14,04	8,26	99,7	1741	14645	4184
770	15,43	7,62	90,7	1838	15153	4329
770	15,73	7,48	89,0	1859	15264	4361
770	17,29	6,80	81,0	1962	15832	4523
770	19,03	6,18	73,6	2055	16420	4691
770	20,14	5,84	69,5	2107	16778	4794
800	22,13	5,52	63,3	2154	17288	4939
800	24,00	5,09	58,3	2219	17830	5094
800	26,05	4,69	53,8	2280	18000	5254
900	27,29	5,04	51,3	2228	18000	5253
900	28,67	4,79	48,8	2264	18000	5354
900	29,60	4,64	47,3	2287	18000	5419
1000	31,78	4,81	44,1	2262	18000	5474
1000	34,91	4,37	40,1	2327	18000	5676
1000	35,50	4,30	39,4	2338	18000	5713
1000	40,05	3,81	35,0	2412	18000	5983
1000	43,05	3,55	32,5	2452	18000	6150
1000	50,25	3,04	27,9	2529	18000	6521
1000	54,27	2,81	25,8	2563	18000	6712
1000	61,98	2,46	22,6	2616	18000	7055

IS083

Mn ₂ [Nm]	i	Pn ₁ [kW]	n ₂ [rpm]	Fr1 [N]	Fr2 D [N]	Fr2 C-L [N]
1000	67,52	2,31	20,7	2646	18000	7200
1000	74,18	2,10	18,9	2677	18000	7200
1000	81,71	1,91	17,1	2705	18000	7200
1000	91,49	1,70	15,3	2735	18000	7200
1000	100,62	1,55	13,9	2758	18000	7200
1000	117,17	1,33	11,9	2791	18000	7200
1000	128,73	1,21	10,9	2808	18000	7200
1000	136,34	1,14	10,3	2818	18000	7200
1000	158,76	0,98	8,8	2842	18000	7200
1000	184,88	0,84	7,6	2863	18000	7200
1000	203,11	0,77	6,9	2874	18000	7200
1000	205,34	0,76	6,8	2875	18000	7200
1000	226,04	0,69	6,2	2885	18000	7200
1000	250,50	0,62	5,6	2895	18000	7200
1000	266,13	0,59	5,3	2901	18000	7200
1000	292,36	0,53	4,8	2908	18000	7200
1000	315,73	0,49	4,4	2914	18000	7200
1000	360,58	0,43	3,9	2923	18000	7200

IS102

Mn ₂ [Nm]	i	Pn ₁ [kW]	n ₂ [rpm]	Fr1 [N]	Fr2 D [N]	Fr2 C-L [N]
850	8,06	16,10	173,6	647	15163	4332
900	8,85	15,54	158,3	729	15574	4450
950	10,88	13,33	128,6	1050	16712	4775
1000	12,75	11,98	109,8	1247	17610	5032
1200	13,99	13,10	100,1	1084	17719	5063
1250	15,43	12,37	90,7	1189	18274	5221
1300	17,21	11,53	81,3	1311	18935	5410
1400	19,00	11,25	73,7	1352	19415	5547
1400	20,83	10,26	67,2	1496	20125	5750
1400	22,13	9,66	63,3	1583	20603	5886
1500	24,28	9,44	57,7	1616	21097	6028
1500	26,33	8,70	53,2	1724	21777	6222
1500	29,87	7,67	46,9	1873	22000	6533
1500	32,40	7,07	43,2	1961	22000	6741
1400	34,91	6,12	40,1	2098	22000	7011
1500	38,30	5,98	36,5	2119	22000	7187
1400	42,53	5,03	32,9	2258	22000	7553
1300	44,00	4,51	31,8	2333	22000	7724
1600	47,13	5,18	29,7	2235	22000	7701
1400	50,25	4,25	27,9	2370	22000	8039

IS102

Mn ₂ [Nm]	i	Pn ₁ [kW]	n ₂ [rpm]	Fr1 [N]	Fr2 D [N]	Fr2 C-L [N]
1300	55,14	3,60	25,4	2465	22000	8396
1600	59,40	4,11	23,6	2391	22000	8406
1600	67,84	3,60	20,6	2465	22000	8836

IS103

Mn ₂ [Nm]	i	Pn ₁ [kW]	n ₂ [rpm]	Fr1 [N]	Fr2 D [N]	Fr2 C-L [N]
1600	74,18	3,36	18,9	2510	22000	9000
1600	81,39	3,07	17,2	2552	22000	9000
1600	89,77	2,78	15,6	2593	22000	9000
1600	100,15	2,49	14,0	2634	22000	9000
1600	110,55	2,26	12,7	2667	22000	9000
1600	121,29	2,06	11,5	2696	22000	9000
1600	128,73	1,94	10,9	2713	22000	9000
1600	141,24	1,77	9,9	2737	22000	9000
1600	173,78	1,44	8,1	2784	22000	9000
1600	188,51	1,32	7,4	2800	22000	9000
1600	203,11	1,23	6,9	2814	22000	9000
1600	222,85	1,12	6,3	2829	22000	9000
1600	224,76	1,11	6,2	2831	22000	9000
1600	274,20	0,91	5,1	2859	22000	9000
1600	280,89	0,89	5,0	2862	22000	9000
1600	292,36	0,85	4,8	2867	22000	9000
1600	320,79	0,78	4,4	2878	22000	9000
1600	345,60	0,72	4,0	2886	22000	9000
1600	394,69	0,63	3,5	2899	22000	9000

IS122

Mn ₂ [Nm]	i	Pn ₁ [kW]	n ₂ [rpm]	Fr1 [N]	Fr2 D [N]	Fr2 C-L [N]
1500	8,48	27,00	165,1	2951	19587	5596
1700	9,30	27,92	150,6	2916	19606	5602
1700	10,24	25,36	136,7	3013	20448	5842
1900	11,42	25,41	122,6	3010	20674	5907
2200	12,63	26,61	110,9	2966	20480	5851
2400	13,84	26,48	101,2	2970	20608	5888
2600	16,99	23,36	82,4	3087	21932	6266
2800	21,25	20,12	65,9	3209	23608	6745
2800	22,37	19,12	62,6	3247	24191	6912
2900	23,29	19,01	60,1	3251	24280	6937
3000	26,15	17,52	53,5	3307	25277	7222

IS122

Mn ₂ [Nm]	i	Pn ₁ [kW]	n ₂ [rpm]	Fr1 [N]	Fr2 D [N]	Fr2 C-L [N]
3000	28,60	16,02	49,0	3364	26374	7535
3000	30,51	15,01	45,9	3401	27189	7768
3000	32,76	13,99	42,7	3440	28102	8029
3000	33,44	13,70	41,9	3451	28374	8107
3000	35,20	13,01	39,8	3476	29050	8300
3000	41,07	11,16	34,1	3546	30000	8903
3000	43,60	10,51	32,1	3571	30000	9145
2400	44,63	8,21	31,4	3657	30000	9890
2400	49,04	7,47	28,6	3685	30000	10285
2600	53,75	7,39	26,1	3688	30000	10464
3000	66,00	6,94	21,2	3705	30000	10962

IS123

Mn ₂ [Nm]	i	Pn ₁ [kW]	n ₂ [rpm]	Fr1 [N]	Fr2 D [N]	Fr2 C-L [N]
2700	64,84	6,49	21,6	3727	30000	11200
2700	71,07	5,92	19,7	3748	30000	11200
3000	78,46	5,96	17,8	3746	30000	11200
3000	87,27	5,36	16,0	3768	30000	11200
3000	105,91	4,42	13,2	3803	30000	11200
3000	112,52	4,16	12,4	3813	30000	11200
3000	123,33	3,79	11,3	3826	30000	11200
3000	130,04	3,60	10,8	3833	30000	11200
3000	133,78	3,50	10,5	3837	30000	11200
3000	151,43	3,09	9,2	3852	30000	11200
3000	177,53	2,64	7,9	3869	30000	11200
3000	194,59	2,40	7,2	3877	30000	11200
3000	215,60	2,17	6,5	3886	30000	11200
3000	238,93	1,96	5,9	3894	30000	11200

IS142

Mn ₂ [Nm]	i	Pn ₁ [kW]	n ₂ [rpm]	Fr1 [N]	Fr2 D [N]	Fr2 C-L [N]
1389	4,12	51,51	340,0	2398	20752	11858
1548	4,59	51,55	305,3	2397	20645	11797
1737	5,14	51,58	272,2	2395	20421	11669
1964	5,82	51,54	240,6	2397	20052	11458
2099	6,21	51,59	225,3	2395	19762	11293
1915	7,32	39,97	191,3	2957	23226	13272
2149	8,21	39,98	170,6	2957	22867	13067
2432	9,29	39,99	150,8	2956	22289	12736

IS142

Mn ₂ [Nm]	i	Pn ₁ [kW]	n ₂ [rpm]	Fr1 [N]	Fr2 D [N]	Fr2 C-L [N]
2597	9,91	40,00	141,2	2956	21893	12510
2816	11,41	37,70	122,7	3067	22171	12669
2620	12,81	31,23	109,3	3381	25452	14544
2440	14,27	26,11	98,1	3628	28542	16309
2652	16,01	25,30	87,5	3668	28716	16409
3000	18,11	25,30	77,3	3668	28033	16019
3204	19,33	25,30	72,4	3667	27555	15746
3315	22,24	22,76	62,9	3791	29179	16674
2896	25,26	17,51	55,4	4045	34856	18500
3248	28,33	17,50	49,4	4045	34308	18500
3674	32,05	17,50	43,7	4045	33434	18500
3923	34,22	17,50	40,9	4045	32836	18500
4431	39,38	17,18	35,6	4061	31852	18201

IS143

Mn ₂ [Nm]	i	Pn ₁ [kW]	n ₂ [rpm]	Fr1 [N]	Fr2 D [N]	Fr2 C-L [N]
4013	45,77	13,67	30,6	4200	35000	18500
4470	50,97	13,68	27,5	4200	35000	18500
4735	57,17	12,91	24,5	4200	35000	18500
4774	64,68	11,51	21,6	4200	35000	18500
4876	69,06	11,01	20,3	4200	35000	18500
4233	79,45	8,31	17,6	4200	35000	18500
4440	98,81	7,01	14,2	4200	35000	18500
4734	110,05	6,71	12,7	4200	35000	18500
4754	123,44	6,01	11,3	4200	35000	18500
4841	139,64	5,41	10,0	4200	35000	18500
4786	149,10	5,01	9,4	4200	35000	18500
3801	157,49	3,76	8,9	4200	35000	18500
4669	171,55	4,24	8,2	4200	35000	18500
4234	175,41	3,76	8,0	4200	35000	18500
4749	196,74	3,76	7,1	4200	35000	18500
4715	222,57	3,30	6,3	4200	35000	18500
4882	237,63	3,20	5,9	4200	35000	18500
4792	273,41	2,73	5,1	4200	35000	18500

IS152

Mn ₂ [Nm]	i	Pn ₁ [kW]	n ₂ [rpm]	Fr1 [N]	Fr2 D [N]	Fr2 C-L [N]
2573	4,06	96,75	344,7	2801	25156	14375
2871	4,53	96,72	308,9	2802	25081	14332

IS152

Mn_2 [Nm]	i	Pn_1 [kW]	n_2 [rpm]	Fr_1 [N]	Fr_2 D [N]	Fr_2 C-L [N]
2914	5,20	85,51	269,0	3131	26699	15256
2942	5,71	78,66	245,1	3333	27843	15910
3075	6,52	71,99	214,6	3529	29085	16620
3259	7,28	68,36	192,3	3635	29810	17034
3531	8,36	64,52	167,5	3748	30605	17488
3751	9,17	62,44	152,6	3809	31016	17723
4182	10,42	61,29	134,4	3843	31012	17721
3306	12,46	40,50	112,3	4454	38494	19400
3688	13,91	40,49	100,7	4454	38629	19400
4234	15,97	40,49	87,7	4454	38576	19400
4648	17,53	40,50	79,9	4454	38385	19400
5280	19,91	40,50	70,3	4454	37896	19400
6070	22,88	40,51	61,2	4454	36997	19400
6089	27,11	34,30	51,6	4636	40000	19400
6685	29,75	34,31	47,1	4636	40000	19400
7592	33,79	34,31	41,4	4636	38670	19400
7689	38,84	30,23	36,0	4756	40000	19400

IS153

Mn_2 [Nm]	i	Pn_1 [kW]	n_2 [rpm]	Fr_1 [N]	Fr_2 D [N]	Fr_2 C-L [N]
6281	40,10	24,43	34,9	4941	40000	19400
7010	44,76	24,43	31,3	4941	40000	19400
7865	51,38	23,87	27,2	4957	40000	19400
8254	56,39	22,83	24,8	4987	40000	19400
8795	64,05	21,41	21,9	5028	40000	19400
7779	73,63	16,48	19,0	5170	40000	19400
7105	87,16	12,71	16,1	5200	40000	19400
7931	97,27	12,71	14,4	5200	40000	19400
9104	111,67	12,71	12,5	5200	40000	19400
9536	122,57	12,13	11,4	5200	40000	19400
9142	139,21	10,24	10,1	5200	40000	19400
7129	154,02	7,22	9,1	5200	40000	19400
8084	160,02	7,88	8,8	5200	40000	19400
8184	176,81	7,22	7,9	5200	40000	19400
8982	194,06	7,22	7,2	5200	40000	19400
9353	220,42	6,62	6,3	5200	40000	19400
8279	253,36	5,10	5,5	5200	40000	19400

IS052

Mn ₂ [Nm]	i	Pn ₁ [kW]	n ₂ [rpm]	Fr1 [N]	Fr2 D [N]	Fr2 C-L [N]
174	8,63	2,51	132,2	700	3657	3657
195	11,14	2,17	102,3	795	3949	3949
205	12,00	2,12	95,0	809	4016	4016
215	13,66	1,96	83,5	855	4183	4183
246	15,27	2,00	74,6	843	4209	4209
246	16,29	1,88	70,0	878	4330	4330
246	18,63	1,64	61,2	945	4591	4591
246	19,73	1,55	57,8	971	4706	4706
267	21,04	1,58	54,2	964	4718	4718
267	21,53	1,54	53,0	974	4766	4766
267	24,07	1,38	47,4	1019	5003	5003
297	25,20	1,47	45,2	994	4924	4924
297	25,79	1,43	44,2	1003	4975	4975
297	27,81	1,33	41,0	1033	5144	5144
297	30,00	1,23	38,0	1060	5318	5318
308	32,55	1,17	35,0	1076	5451	5451
308	33,00	1,16	34,5	1081	5484	5484
308	34,09	1,12	33,4	1091	5562	5562
338	36,55	1,15	31,2	1083	5554	5554
338	38,75	1,09	29,4	1101	5701	5701
359	39,90	1,12	28,6	1092	5656	5656
359	42,63	1,05	26,7	1112	5827	5827
359	46,00	0,97	24,8	1134	6000	6000
359	47,20	0,95	24,1	1141	6000	6000
359	52,25	0,85	21,8	1166	6000	6000
359	57,86	0,77	19,7	1190	6000	6000
359	59,42	0,75	19,2	1195	6000	6000
359	72,83	0,61	15,7	1234	6000	6000

IS053

Mn ₂ [Nm]	i	Pn ₁ [kW]	n ₂ [rpm]	Fr1 [N]	Fr2 D [N]	Fr2 C-L [N]
359	36,50	1,25	31,2	1063	5432	5432
359	47,14	0,97	24,2	1140	6000	6000
359	57,79	0,79	19,7	1189	6000	6000
359	63,74	0,71	17,9	1210	6000	6000
359	74,20	0,61	15,4	1237	6000	6000
359	78,14	0,58	14,6	1246	6000	6000
359	95,84	0,48	11,9	1276	6000	6000
359	117,48	0,39	9,7	1300	6000	6000
359	137,45	0,33	8,3	1315	6000	6000
359	177,55	0,26	6,4	1336	6000	6000

IS053

Mn ₂ [Nm]	i	Pn ₁ [kW]	n ₂ [rpm]	Fr1 [N]	Fr2 D [N]	Fr2 C-L [N]
359	198,45	0,23	5,7	1343	6000	6000
359	217,64	0,21	5,2	1349	6000	6000
359	256,33	0,18	4,5	1357	6000	6000
359	314,21	0,14	3,6	1367	6000	6000

IS062

Mn ₂ [Nm]	i	Pn ₁ [kW]	n ₂ [rpm]	Fr1 [N]	Fr2 D [N]	Fr2 C-L [N]
338	8,00	5,26	142,5	323	5686	2275
338	8,92	4,71	127,8	435	5973	2389
369	9,55	4,81	119,4	416	5962	2385
369	10,65	4,31	107,1	519	6266	2506
400	11,71	4,25	97,4	532	6346	2538
431	13,06	4,10	87,3	562	6476	2590
431	13,36	4,01	85,3	581	6545	2618
461	15,94	3,60	71,5	666	6907	2763
461	16,16	3,55	70,5	676	6952	2781
461	19,29	2,97	59,1	795	7545	3018
472	19,55	3,00	58,3	790	7527	3011
482	23,18	2,58	49,2	875	8070	3228
482	23,75	2,52	48,0	888	8160	3264
492	25,14	2,43	45,3	906	8308	3323
492	27,66	2,21	41,2	952	8673	3469
513	30,00	2,12	38,0	970	8864	3545
554	33,93	2,03	33,6	990	9105	3642
615	36,57	2,09	31,2	977	9032	3613
615	39,38	1,94	28,9	1008	9351	3740
615	43,64	1,75	26,1	1047	9808	3923
615	46,10	1,66	24,7	1066	10000	4000
615	48,30	1,58	23,6	1082	10000	4000
615	53,53	1,43	21,3	1114	10000	4000
615	55,00	1,39	20,7	1122	10000	4000
615	67,47	1,13	16,9	1175	10000	4000

IS063

Mn ₂ [Nm]	i	Pn ₁ [kW]	n ₂ [rpm]	Fr1 [N]	Fr2 D [N]	Fr2 C-L [N]
615	33,57	2,33	34,0	939	8672	3469
615	37,77	2,07	30,2	991	9171	3668
615	40,05	1,95	28,5	1015	9426	3770
615	49,13	1,59	23,2	1088	10000	4000

IS063

Mn ₂ [Nm]	i	Pn ₁ [kW]	n ₂ [rpm]	Fr1 [N]	Fr2 D [N]	Fr2 C-L [N]
615	55,29	1,41	20,6	1123	10000	4000
615	58,72	1,33	19,4	1140	10000	4000
615	65,85	1,19	17,3	1169	10000	4000
615	68,25	1,14	16,7	1178	10000	4000
615	73,63	1,06	15,5	1194	10000	4000
615	81,43	0,96	14,0	1215	10000	4000
615	99,89	0,78	11,4	1251	10000	4000
615	126,43	0,62	9,0	1284	10000	4000
615	150,85	0,52	7,6	1304	10000	4000
615	182,53	0,43	6,2	1322	10000	4000
615	185,05	0,42	6,2	1324	10000	4000
615	217,79	0,36	5,2	1336	10000	4000
615	267,16	0,29	4,3	1350	10000	4000

IS082

Mn ₂ [Nm]	i	Pn ₁ [kW]	n ₂ [rpm]	Fr1 [N]	Fr2 D [N]	Fr2 C-L [N]
564	7,34	9,55	155,3	1218	12956	3702
615	8,06	9,48	141,4	1230	13254	3787
666	9,94	8,33	114,6	1444	14180	4052
718	11,61	7,69	98,2	1563	14869	4248
769	12,75	7,50	89,4	1599	15243	4355
779	14,04	6,90	81,2	1710	15785	4510
789	15,43	6,36	73,9	1809	16330	4666
789	15,73	6,24	72,5	1831	16449	4700
789	17,29	5,67	65,9	1936	17056	4873
789	19,03	5,16	59,9	2032	17686	5053
789	20,14	4,87	56,6	2085	18000	5163
820	22,13	4,61	51,5	2134	18000	5320
820	24,00	4,25	47,5	2200	18000	5485
820	26,05	3,91	43,8	2262	18000	5657
923	27,29	4,20	41,8	2209	18000	5660
923	28,67	4,00	39,8	2246	18000	5767
923	29,60	3,88	38,5	2269	18000	5837
1025	31,78	4,01	35,9	2244	18000	5900
1025	34,91	3,65	32,7	2311	18000	6116
1025	35,50	3,59	32,1	2322	18000	6156
1025	40,05	3,18	28,5	2398	18000	6445
1025	43,05	2,96	26,5	2439	18000	6624
1025	50,25	2,54	22,7	2517	18000	7020
1025	54,27	2,35	21,0	2552	18000	7200
1025	61,98	2,06	18,4	2606	18000	7200

IS083

Mn ₂ [Nm]	i	Pn ₁ [kW]	n ₂ [rpm]	Fr1 [N]	Fr2 D [N]	Fr2 C-L [N]
1025	67,52	1,93	16,9	2638	18000	7200
1025	74,18	1,75	15,4	2669	18000	7200
1025	81,71	1,59	13,9	2698	18000	7200
1025	91,49	1,42	12,5	2729	18000	7200
1025	100,62	1,29	11,3	2753	18000	7200
1025	117,17	1,11	9,7	2786	18000	7200
1025	128,73	1,01	8,9	2804	18000	7200
1025	136,34	0,95	8,4	2814	18000	7200
1025	158,76	0,82	7,2	2838	18000	7200
1025	184,88	0,70	6,2	2859	18000	7200
1025	203,11	0,64	5,6	2871	18000	7200
1025	205,34	0,63	5,5	2872	18000	7200
1025	226,04	0,58	5,0	2883	18000	7200
1025	250,50	0,52	4,5	2893	18000	7200
1025	266,13	0,49	4,3	2898	18000	7200
1025	292,36	0,45	3,9	2906	18000	7200
1025	315,73	0,41	3,6	2912	18000	7200
1025	360,58	0,36	3,2	2922	18000	7200

IS102

Mn ₂ [Nm]	i	Pn ₁ [kW]	n ₂ [rpm]	Fr1 [N]	Fr2 D [N]	Fr2 C-L [N]
871	8,06	13,44	141,4	589	16327	4665
923	8,85	12,97	128,9	673	16772	4792
974	10,88	11,12	104,7	1002	17996	5142
1025	12,75	10,00	89,4	1203	18963	5418
1230	13,99	10,93	81,5	1036	19103	5458
1281	15,43	10,33	73,9	1144	19702	5629
1333	17,21	9,63	66,2	1269	20416	5833
1435	19,00	9,39	60,0	1311	20941	5983
1435	20,83	8,57	54,7	1459	21700	6200
1435	22,13	8,06	51,5	1548	22000	6346
1538	24,28	7,88	47,0	1582	22000	6501
1538	26,33	7,26	43,3	1692	22000	6709
1538	29,87	6,40	38,2	1845	22000	7042
1538	32,40	5,90	35,2	1935	22000	7264
1435	34,91	5,11	32,7	2076	22000	7550
1538	38,30	4,99	29,8	2097	22000	7742
1435	42,53	4,20	26,8	2239	22000	8129
1333	44,00	3,77	25,9	2316	22000	8309
1640	47,13	4,33	24,2	2216	22000	8295
1435	50,25	3,55	22,7	2355	22000	8650

IS102

Mn ₂ [Nm]	i	Pn ₁ [kW]	n ₂ [rpm]	Fr1 [N]	Fr2 D [N]	Fr2 C-L [N]
1333	55,14	3,01	20,7	2452	22000	9000
1640	59,40	3,43	19,2	2376	22000	9000
1640	67,84	3,01	16,8	2452	22000	9000

IS103

Mn ₂ [Nm]	i	Pn ₁ [kW]	n ₂ [rpm]	Fr1 [N]	Fr2 D [N]	Fr2 C-L [N]
1640	74,18	2,81	15,4	2498	22000	9000
1640	81,39	2,56	14,0	2541	22000	9000
1640	89,77	2,32	12,7	2583	22000	9000
1640	100,15	2,08	11,4	2625	22000	9000
1640	110,55	1,88	10,3	2659	22000	9000
1640	121,29	1,72	9,4	2689	22000	9000
1640	128,73	1,62	8,9	2706	22000	9000
1640	141,24	1,47	8,1	2731	22000	9000
1640	173,78	1,20	6,6	2779	22000	9000
1640	188,51	1,10	6,0	2796	22000	9000
1640	203,11	1,03	5,6	2810	22000	9000
1640	222,85	0,93	5,1	2825	22000	9000
1640	224,76	0,93	5,1	2827	22000	9000
1640	274,20	0,76	4,2	2856	22000	9000
1640	280,89	0,74	4,1	2859	22000	9000
1640	292,36	0,71	3,9	2864	22000	9000
1640	320,79	0,65	3,5	2875	22000	9000
1640	345,60	0,60	3,3	2883	22000	9000
1640	394,69	0,53	2,9	2897	22000	9000

IS122

Mn ₂ [Nm]	i	Pn ₁ [kW]	n ₂ [rpm]	Fr1 [N]	Fr2 D [N]	Fr2 C-L [N]
1538	8,48	22,54	134,4	2925	21217	6062
1743	9,30	23,30	122,6	2890	21272	6078
1743	10,24	21,16	111,3	2989	22173	6335
1948	11,42	21,21	99,9	2987	22449	6414
2255	12,63	22,21	90,3	2941	22293	6369
2460	13,84	22,10	82,4	2945	22464	6418
2665	16,99	19,50	67,1	3066	23915	6833
2870	21,25	16,79	53,6	3190	25743	7355
2870	22,37	15,96	51,0	3229	26367	7533
2973	23,29	15,87	48,9	3233	26480	7566
3075	26,15	14,62	43,6	3291	27563	7875

IS122

Mn ₂ [Nm]	i	Pn ₁ [kW]	n ₂ [rpm]	Fr1 [N]	Fr2 D [N]	Fr2 C-L [N]
3075	28,60	13,37	39,9	3349	28737	8211
3075	30,51	12,53	37,4	3387	29609	8460
3075	32,76	11,67	34,8	3427	30000	8739
3075	33,44	11,43	34,1	3438	30000	8822
3075	35,20	10,86	32,4	3464	30000	9029
3075	41,07	9,31	27,8	3536	30000	9674
3075	43,60	8,77	26,1	3561	30000	9933
2460	44,63	6,85	25,5	3649	30000	10701
2460	49,04	6,24	23,2	3678	30000	11123
2665	53,75	6,17	21,2	3681	30000	11200
3075	66,00	5,79	17,3	3698	30000	11200

IS123

Mn ₂ [Nm]	i	Pn ₁ [kW]	n ₂ [rpm]	Fr1 [N]	Fr2 D [N]	Fr2 C-L [N]
2768	64,84	5,42	17,6	3721	30000	11200
2768	71,07	4,95	16,0	3742	30000	11200
3075	78,46	4,98	14,5	3741	30000	11200
3075	87,27	4,47	13,1	3763	30000	11200
3075	105,91	3,69	10,8	3799	30000	11200
3075	112,52	3,47	10,1	3809	30000	11200
3075	123,33	3,17	9,2	3822	30000	11200
3075	130,04	3,00	8,8	3830	30000	11200
3075	133,78	2,92	8,5	3834	30000	11200
3075	151,43	2,58	7,5	3849	30000	11200
3075	177,53	2,20	6,4	3866	30000	11200
3075	194,59	2,01	5,9	3875	30000	11200
3075	215,60	1,81	5,3	3884	30000	11200
3075	238,93	1,63	4,8	3892	30000	11200

IS142

Mn ₂ [Nm]	i	Pn ₁ [kW]	n ₂ [rpm]	Fr1 [N]	Fr2 D [N]	Fr2 C-L [N]
1424	4,12	43,00	276,9	2336	22702	12973
1587	4,59	43,03	248,6	2334	22644	12940
1781	5,14	43,05	221,6	2333	22472	12841
2013	5,82	43,02	195,9	2335	22158	12662
2152	6,21	43,06	183,5	2332	21896	12512
1963	7,32	33,36	155,8	2909	25537	14593
2202	8,21	33,37	138,9	2909	25236	14420
2492	9,29	33,38	122,8	2908	24718	14124

IS142

Mn_2 [Nm]	i	Pn_1 [kW]	n2 [rpm]	Fr1 [N]	Fr2 D [N]	Fr2 C-L [N]
2662	9,91	33,39	115,0	2908	24353	13916
2886	11,41	31,47	100,0	3022	24729	14131
2686	12,81	26,06	89,0	3343	28171	16098
2501	14,27	21,79	79,9	3597	31412	17950
2718	16,01	21,12	71,2	3637	31675	18100
3075	18,11	21,11	63,0	3637	31068	17753
3284	19,33	21,12	59,0	3637	30628	17502
3398	22,24	18,99	51,2	3763	32406	18500
2968	25,26	14,61	45,1	4024	35000	18500
3329	28,33	14,61	40,2	4024	35000	18500
3766	32,05	14,61	35,6	4024	35000	18500
4021	34,22	14,61	33,3	4024	35000	18500
4542	39,38	14,34	28,9	4040	35000	18500

IS143

Mn_2 [Nm]	i	Pn_1 [kW]	n2 [rpm]	Fr1 [N]	Fr2 D [N]	Fr2 C-L [N]
4113	45,77	11,41	24,9	4200	35000	18500
4582	50,97	11,41	22,4	4200	35000	18500
4853	57,17	10,78	19,9	4200	35000	18500
4894	64,68	9,61	17,6	4200	35000	18500
4998	69,06	9,19	16,5	4200	35000	18500
4339	79,45	6,94	14,3	4200	35000	18500
4551	98,81	5,85	11,5	4200	35000	18500
4852	110,05	5,60	10,4	4200	35000	18500
4873	123,44	5,01	9,2	4200	35000	18500
4962	139,64	4,51	8,2	4200	35000	18500
4905	149,10	4,18	7,7	4200	35000	18500
3896	157,49	3,14	7,2	4200	35000	18500
4786	171,55	3,54	6,7	4200	35000	18500
4340	175,41	3,14	6,5	4200	35000	18500
4867	196,74	3,14	5,8	4200	35000	18500
4833	222,57	2,76	5,1	4200	35000	18500
5004	237,63	2,67	4,8	4200	35000	18500
4912	273,41	2,28	4,2	4200	35000	18500

IS152

Mn_2 [Nm]	i	Pn_1 [kW]	n2 [rpm]	Fr1 [N]	Fr2 D [N]	Fr2 C-L [N]
2638	4,06	80,75	280,7	2730	27495	15711
2943	4,53	80,73	251,5	2731	27481	15703

IS152

Mn ₂ [Nm]	i	Pn ₁ [kW]	n ₂ [rpm]	Fr1 [N]	Fr2 D [N]	Fr2 C-L [N]
2987	5,20	71,37	219,1	3068	29222	16698
3016	5,71	65,65	199,6	3275	30453	17402
3152	6,52	60,08	174,8	3476	31812	18178
3340	7,28	57,06	156,6	3585	32628	18645
3619	8,36	53,85	136,4	3701	33540	19166
3845	9,17	52,12	124,3	3763	34029	19400
4287	10,42	51,16	109,4	3798	34121	19400
3388	12,46	33,81	91,5	4424	40000	19400
3780	13,91	33,79	82,0	4425	40000	19400
4340	15,97	33,80	71,4	4425	40000	19400
4764	17,53	33,80	65,0	4424	40000	19400
5412	19,91	33,80	57,3	4424	40000	19400
6222	22,88	33,81	49,8	4424	40000	19400
6241	27,11	28,63	42,1	4611	40000	19400
6852	29,75	28,64	38,3	4611	40000	19400
7782	33,79	28,64	33,7	4611	40000	19400
7881	38,84	25,23	29,4	4734	40000	19400

IS153

Mn ₂ [Nm]	i	Pn ₁ [kW]	n ₂ [rpm]	Fr1 [N]	Fr2 D [N]	Fr2 C-L [N]
6438	40,10	20,39	28,4	4924	40000	19400
7185	44,76	20,39	25,5	4924	40000	19400
8062	51,38	19,93	22,2	4940	40000	19400
8460	56,39	19,05	20,2	4971	40000	19400
9015	64,05	17,87	17,8	5013	40000	19400
7974	73,63	13,75	15,5	5158	40000	19400
7283	87,16	10,61	13,1	5200	40000	19400
8129	97,27	10,61	11,7	5200	40000	19400
9331	111,67	10,61	10,2	5200	40000	19400
9775	122,57	10,13	9,3	5200	40000	19400
9370	139,21	8,55	8,2	5200	40000	19400
7307	154,02	6,02	7,4	5200	40000	19400
8286	160,02	6,58	7,1	5200	40000	19400
8389	176,81	6,02	6,5	5200	40000	19400
9206	194,06	6,02	5,9	5200	40000	19400
9587	220,42	5,52	5,2	5200	40000	19400
8486	253,36	4,25	4,5	5200	40000	19400

IS052

Mn ₂ [Nm]	i	Pn ₁ [kW]	n ₂ [rpm]	Fr1 [N]	Fr2 D [N]	Fr2 C-L [N]
179	8,63	2,01	104,3	683	4011	4011
200	11,14	1,74	80,8	781	4334	4334
210	12,00	1,70	75,0	795	4409	4409
221	13,66	1,57	65,9	842	4593	4593
252	15,27	1,60	58,9	830	4631	4631
252	16,29	1,50	55,3	866	4762	4762
252	18,63	1,31	48,3	934	5045	5045
252	19,73	1,24	45,6	960	5169	5169
273	21,04	1,26	42,8	953	5189	5189
273	21,53	1,23	41,8	963	5241	5241
273	24,07	1,10	37,4	1010	5496	5496
305	25,20	1,17	35,7	984	5422	5422
305	25,79	1,15	34,9	994	5476	5476
305	27,81	1,06	32,4	1024	5659	5659
305	30,00	0,99	30,0	1052	5848	5848
315	32,55	0,94	27,6	1068	5994	5994
315	33,00	0,93	27,3	1073	6000	6000
315	34,09	0,90	26,4	1083	6000	6000
347	36,55	0,92	24,6	1075	6000	6000
347	38,75	0,87	23,2	1094	6000	6000
368	39,90	0,90	22,6	1084	6000	6000
368	42,63	0,84	21,1	1105	6000	6000
368	46,00	0,78	19,6	1127	6000	6000
368	47,20	0,76	19,1	1134	6000	6000
368	52,25	0,68	17,2	1161	6000	6000
368	57,86	0,62	15,6	1184	6000	6000
368	59,42	0,60	15,2	1190	6000	6000
368	72,83	0,49	12,4	1230	6000	6000

IS053

Mn ₂ [Nm]	i	Pn ₁ [kW]	n ₂ [rpm]	Fr1 [N]	Fr2 D [N]	Fr2 C-L [N]
368	36,50	1,00	24,7	1054	5991	5991
368	47,14	0,77	19,1	1134	6000	6000
368	57,79	0,63	15,6	1184	6000	6000
368	63,74	0,57	14,1	1205	6000	6000
368	74,20	0,49	12,1	1233	6000	6000
368	78,14	0,47	11,5	1242	6000	6000
368	95,84	0,38	9,4	1272	6000	6000
368	117,48	0,31	7,7	1297	6000	6000
368	137,45	0,27	6,5	1313	6000	6000
368	177,55	0,21	5,1	1334	6000	6000

IS053

Mn ₂ [Nm]	i	Pn ₁ [kW]	n ₂ [rpm]	Fr1 [N]	Fr2 D [N]	Fr2 C-L [N]
368	198,45	0,18	4,5	1342	6000	6000
368	217,64	0,17	4,1	1347	6000	6000
368	256,33	0,14	3,5	1356	6000	6000
368	314,21	0,12	2,9	1366	6000	6000

IS062

Mn ₂ [Nm]	i	Pn ₁ [kW]	n ₂ [rpm]	Fr1 [N]	Fr2 D [N]	Fr2 C-L [N]
347	8,00	4,21	112,5	297	6269	2508
347	8,92	3,77	100,9	412	6580	2632
378	9,55	3,85	94,3	392	6578	2631
378	10,65	3,45	84,5	497	6907	2763
410	11,71	3,40	76,9	511	7004	2802
441	13,06	3,28	68,9	542	7156	2862
441	13,36	3,21	67,4	561	7231	2892
473	15,94	2,88	56,5	648	7633	3053
473	16,16	2,84	55,7	658	7682	3073
473	19,29	2,38	46,7	780	8323	3329
483	19,55	2,40	46,0	775	8308	3323
494	23,18	2,07	38,8	862	8898	3559
494	23,75	2,02	37,9	875	8995	3598
504	25,14	1,95	35,8	894	9159	3663
504	27,66	1,77	32,5	941	9553	3821
525	30,00	1,70	30,0	960	9767	3907
567	33,93	1,62	26,5	980	10000	4000
630	36,57	1,67	24,6	967	9986	3994
630	39,38	1,56	22,9	998	10000	4000
630	43,64	1,40	20,6	1038	10000	4000
630	46,10	1,33	19,5	1058	10000	4000
630	48,30	1,27	18,6	1074	10000	4000
630	53,53	1,14	16,8	1107	10000	4000
630	55,00	1,11	16,4	1115	10000	4000
630	67,47	0,91	13,3	1169	10000	4000

IS063

Mn ₂ [Nm]	i	Pn ₁ [kW]	n ₂ [rpm]	Fr1 [N]	Fr2 D [N]	Fr2 C-L [N]
630	33,57	1,86	26,8	927	9596	3839
630	37,77	1,66	23,8	981	10000	4000
630	40,05	1,56	22,5	1005	10000	4000
630	49,13	1,27	18,3	1080	10000	4000

IS063

Mn ₂ [Nm]	i	Pn ₁ [kW]	n ₂ [rpm]	Fr1 [N]	Fr2 D [N]	Fr2 C-L [N]
630	55,29	1,13	16,3	1116	10000	4000
630	58,72	1,07	15,3	1133	10000	4000
630	65,85	0,95	13,7	1163	10000	4000
630	68,25	0,92	13,2	1172	10000	4000
630	73,63	0,85	12,2	1189	10000	4000
630	81,43	0,77	11,1	1210	10000	4000
630	99,89	0,63	9,0	1247	10000	4000
630	126,43	0,49	7,1	1281	10000	4000
630	150,85	0,41	6,0	1302	10000	4000
630	182,53	0,34	4,9	1320	10000	4000
630	185,05	0,34	4,9	1321	10000	4000
630	217,79	0,29	4,1	1335	10000	4000
630	267,16	0,23	3,4	1348	10000	4000

IS082

Mn ₂ [Nm]	i	Pn ₁ [kW]	n ₂ [rpm]	Fr1 [N]	Fr2 D [N]	Fr2 C-L [N]
578	7,34	7,65	122,6	1175	14112	4032
630	8,06	7,59	111,6	1188	14444	4127
683	9,94	6,67	90,5	1406	15455	4416
735	11,61	6,16	77,5	1529	16209	4631
788	12,75	6,00	70,6	1565	16623	4749
798	14,04	5,52	64,1	1678	17211	4917
809	15,43	5,09	58,3	1780	17802	5086
809	15,73	5,00	57,2	1803	17931	5123
809	17,29	4,54	52,0	1910	18000	5311
809	19,03	4,13	47,3	2009	18000	5505
809	20,14	3,90	44,7	2063	18000	5623
840	22,13	3,69	40,7	2113	18000	5795
840	24,00	3,40	37,5	2181	18000	5974
840	26,05	3,13	34,5	2244	18000	6159
945	27,29	3,37	33,0	2190	18000	6168
945	28,67	3,20	31,4	2228	18000	6285
945	29,60	3,10	30,4	2252	18000	6360
1050	31,78	3,21	28,3	2226	18000	6433
1050	34,91	2,92	25,8	2294	18000	6667
1050	35,50	2,87	25,4	2306	18000	6710
1050	40,05	2,55	22,5	2383	18000	7022
1050	43,05	2,37	20,9	2425	18000	7200
1050	50,25	2,03	17,9	2506	18000	7200
1050	54,27	1,88	16,6	2542	18000	7200
1050	61,98	1,65	14,5	2597	18000	7200

IS083

Mn ₂ [Nm]	i	Pn ₁ [kW]	n ₂ [rpm]	Fr1 [N]	Fr2 D [N]	Fr2 C-L [N]
1050	67,52	1,54	13,3	2629	18000	7200
1050	74,18	1,41	12,1	2661	18000	7200
1050	81,71	1,28	11,0	2691	18000	7200
1050	91,49	1,14	9,8	2723	18000	7200
1050	100,62	1,04	8,9	2747	18000	7200
1050	117,17	0,89	7,7	2781	18000	7200
1050	128,73	0,81	7,0	2799	18000	7200
1050	136,34	0,76	6,6	2810	18000	7200
1050	158,76	0,66	5,7	2835	18000	7200
1050	184,88	0,56	4,9	2856	18000	7200
1050	203,11	0,51	4,4	2868	18000	7200
1050	205,34	0,51	4,4	2869	18000	7200
1050	226,04	0,46	4,0	2880	18000	7200
1050	250,50	0,42	3,6	2891	18000	7200
1050	266,13	0,39	3,4	2896	18000	7200
1050	292,36	0,36	3,1	2904	18000	7200
1050	315,73	0,33	2,9	2911	18000	7200
1050	360,58	0,29	2,5	2920	18000	7200

IS102

Mn ₂ [Nm]	i	Pn ₁ [kW]	n ₂ [rpm]	Fr1 [N]	Fr2 D [N]	Fr2 C-L [N]
893	8,06	10,76	111,6	530	17780	5080
945	8,85	10,38	101,7	616	18268	5220
998	10,88	8,91	82,7	953	19599	5600
1050	12,75	8,00	70,6	1160	20652	5901
1260	13,99	8,75	64,3	988	20834	5953
1313	15,43	8,27	58,3	1099	21489	6140
1365	17,21	7,71	52,3	1227	22000	6362
1470	19,00	7,52	47,4	1270	22000	6529
1470	20,83	6,86	43,2	1421	22000	6763
1470	22,13	6,46	40,7	1513	22000	6922
1575	24,28	6,31	37,1	1548	22000	7093
1575	26,33	5,81	34,2	1660	22000	7318
1575	29,87	5,13	30,1	1818	22000	7678
1575	32,40	4,72	27,8	1909	22000	7918
1470	34,91	4,09	25,8	2054	22000	8223
1575	38,30	4,00	23,5	2076	22000	8434
1470	42,53	3,36	21,2	2221	22000	8849
1365	44,00	3,02	20,4	2300	22000	9000
1680	47,13	3,46	19,1	2197	22000	9000
1470	50,25	2,84	17,9	2339	22000	9000

IS102

Mn ₂ [Nm]	i	Pn ₁ [kW]	n ₂ [rpm]	Fr1 [N]	Fr2 D [N]	Fr2 C-L [N]
1365	55,14	2,41	16,3	2439	22000	9000
1680	59,40	2,75	15,2	2361	22000	9000
1680	67,84	2,41	13,3	2439	22000	9000

IS103

Mn ₂ [Nm]	i	Pn ₁ [kW]	n ₂ [rpm]	Fr1 [N]	Fr2 D [N]	Fr2 C-L [N]
1680	74,18	2,25	12,1	2486	22000	9000
1680	81,39	2,05	11,1	2530	22000	9000
1680	89,77	1,86	10,0	2573	22000	9000
1680	100,15	1,67	9,0	2616	22000	9000
1680	110,55	1,51	8,1	2651	22000	9000
1680	121,29	1,37	7,4	2681	22000	9000
1680	128,73	1,30	7,0	2699	22000	9000
1680	141,24	1,18	6,4	2725	22000	9000
1680	173,78	0,96	5,2	2774	22000	9000
1680	188,51	0,88	4,8	2791	22000	9000
1680	203,11	0,82	4,4	2805	22000	9000
1680	222,85	0,75	4,0	2821	22000	9000
1680	224,76	0,74	4,0	2823	22000	9000
1680	274,20	0,61	3,3	2853	22000	9000
1680	280,89	0,59	3,2	2856	22000	9000
1680	292,36	0,57	3,1	2861	22000	9000
1680	320,79	0,52	2,8	2873	22000	9000
1680	345,60	0,48	2,6	2881	22000	9000
1680	394,69	0,42	2,3	2894	22000	9000

IS122

Mn ₂ [Nm]	i	Pn ₁ [kW]	n ₂ [rpm]	Fr1 [N]	Fr2 D [N]	Fr2 C-L [N]
1575	8,48	18,05	106,1	2900	23269	6648
1785	9,30	18,66	96,8	2864	23372	6678
1785	10,24	16,95	87,9	2965	24346	6956
1995	11,42	16,99	78,8	2963	24689	7054
2310	12,63	17,78	71,3	2916	24586	7025
2520	13,84	17,70	65,0	2921	24815	7090
2730	16,99	15,61	53,0	3044	26428	7551
2940	21,25	13,45	42,4	3172	28448	8128
2940	22,37	12,78	40,2	3211	29123	8321
3045	23,29	12,71	38,6	3215	29267	8362
3150	26,15	11,71	34,4	3274	30000	8703

IS122

Mn ₂ [Nm]	i	Pn ₁ [kW]	n ₂ [rpm]	Fr1 [N]	Fr2 D [N]	Fr2 C-L [N]
3150	28,60	10,71	31,5	3333	30000	9066
3150	30,51	10,03	29,5	3373	30000	9335
3150	32,76	9,35	27,5	3414	30000	9637
3150	33,44	9,15	26,9	3425	30000	9727
3150	35,20	8,70	25,6	3452	30000	9950
3150	41,07	7,46	21,9	3525	30000	10647
3150	43,60	7,02	20,6	3551	30000	10928
2520	44,63	5,49	20,2	3642	30000	11200
2520	49,04	4,99	18,4	3671	30000	11200
2730	53,75	4,94	16,7	3674	30000	11200
3150	66,00	4,64	13,6	3692	30000	11200

IS123

Mn ₂ [Nm]	i	Pn ₁ [kW]	n ₂ [rpm]	Fr1 [N]	Fr2 D [N]	Fr2 C-L [N]
2835	64,84	4,34	13,9	3715	30000	11200
2835	71,07	3,96	12,7	3737	30000	11200
3150	78,46	3,99	11,5	3735	30000	11200
3150	87,27	3,58	10,3	3758	30000	11200
3150	105,91	2,95	8,5	3795	30000	11200
3150	112,52	2,78	8,0	3805	30000	11200
3150	123,33	2,54	7,3	3819	30000	11200
3150	130,04	2,40	6,9	3827	30000	11200
3150	133,78	2,34	6,7	3830	30000	11200
3150	151,43	2,06	5,9	3846	30000	11200
3150	177,53	1,76	5,1	3864	30000	11200
3150	194,59	1,61	4,6	3873	30000	11200
3150	215,60	1,45	4,2	3882	30000	11200
3150	238,93	1,31	3,8	3890	30000	11200

IS142

Mn ₂ [Nm]	i	Pn ₁ [kW]	n ₂ [rpm]	Fr1 [N]	Fr2 D [N]	Fr2 C-L [N]
1458	4,12	34,43	218,6	2274	25181	14389
1626	4,59	34,45	196,2	2272	25192	14395
1824	5,14	34,47	175,0	2270	25092	14338
2062	5,82	34,44	154,7	2273	24856	14204
2204	6,21	34,48	144,9	2270	24635	14077
2011	7,32	26,71	123,0	2861	28487	16279
2256	8,21	26,72	109,7	2860	28268	16153
2553	9,29	26,73	96,9	2860	27839	15908

IS142

Mn_2 [Nm]	i	Pn_1 [kW]	n2 [rpm]	Fr1 [N]	Fr2 D [N]	Fr2 C-L [N]
2727	9,91	26,73	90,8	2859	27520	15726
2957	11,41	25,20	78,9	2976	28027	16015
2751	12,81	20,87	70,2	3305	31658	18090
2562	14,27	17,45	63,1	3565	35000	18500
2784	16,01	16,91	56,2	3606	35000	18500
3150	18,11	16,91	49,7	3607	34964	18500
3364	19,33	16,91	46,5	3606	34583	18500
3481	22,24	15,21	40,5	3736	35000	18500
3041	25,26	11,70	35,6	4003	35000	18500
3410	28,33	11,70	31,8	4003	35000	18500
3858	32,05	11,70	28,1	4003	35000	18500
4119	34,22	11,70	26,3	4003	35000	18500
4652	39,38	11,48	22,9	4019	35000	18500

IS143

Mn_2 [Nm]	i	Pn_1 [kW]	n2 [rpm]	Fr1 [N]	Fr2 D [N]	Fr2 C-L [N]
4214	45,77	9,14	19,7	4200	35000	18500
4693	50,97	9,14	17,7	4200	35000	18500
4971	57,17	8,63	15,7	4200	35000	18500
5013	64,68	7,69	13,9	4200	35000	18500
5120	69,06	7,36	13,0	4200	35000	18500
4445	79,45	5,55	11,3	4200	35000	18500
4662	98,81	4,68	9,1	4200	35000	18500
4970	110,05	4,48	8,2	4200	35000	18500
4992	123,44	4,01	7,3	4200	35000	18500
5083	139,64	3,61	6,4	4200	35000	18500
5025	149,10	3,35	6,0	4200	35000	18500
3991	157,49	2,52	5,7	4200	35000	18500
4903	171,55	2,84	5,2	4200	35000	18500
4446	175,41	2,52	5,1	4200	35000	18500
4986	196,74	2,52	4,6	4200	35000	18500
4951	222,57	2,21	4,0	4200	35000	18500
5126	237,63	2,14	3,8	4200	35000	18500
5031	273,41	1,83	3,3	4200	35000	18500

IS152

Mn_2 [Nm]	i	Pn_1 [kW]	n2 [rpm]	Fr1 [N]	Fr2 D [N]	Fr2 C-L [N]
2702	4,06	64,66	221,6	2659	30466	17409
3015	4,53	64,64	198,6	2660	30536	17449

IS152

Mn ₂ [Nm]	i	Pn ₁ [kW]	n ₂ [rpm]	Fr1 [N]	Fr2 D [N]	Fr2 C-L [N]
3060	5,20	57,15	172,9	3005	32431	18532
3089	5,71	52,57	157,6	3217	33770	19297
3229	6,52	48,11	138,0	3423	35277	19400
3422	7,28	45,69	123,6	3535	36213	19400
3708	8,36	43,12	107,7	3653	37277	19400
3939	9,17	41,73	98,1	3717	37869	19400
4391	10,42	40,96	86,4	3753	38092	19400
3471	12,46	27,07	72,2	4394	40000	19400
3872	13,91	27,06	64,7	4395	40000	19400
4446	15,97	27,06	56,4	4395	40000	19400
4881	17,53	27,07	51,4	4395	40000	19400
5544	19,91	27,07	45,2	4394	40000	19400
6374	22,88	27,07	39,3	4394	40000	19400
6394	27,11	22,93	33,2	4586	40000	19400
7019	29,75	22,93	30,2	4585	40000	19400
7972	33,79	22,93	26,6	4586	40000	19400
8073	38,84	20,20	23,2	4711	40000	19400

IS153

Mn ₂ [Nm]	i	Pn ₁ [kW]	n ₂ [rpm]	Fr1 [N]	Fr2 D [N]	Fr2 C-L [N]
6595	40,10	16,33	22,4	4906	40000	19400
7360	44,76	16,32	20,1	4906	40000	19400
8259	51,38	15,95	17,5	4923	40000	19400
8667	56,39	15,25	16,0	4955	40000	19400
9235	64,05	14,31	14,1	4997	40000	19400
8168	73,63	11,01	12,2	5146	40000	19400
7461	87,16	8,50	10,3	5200	40000	19400
8327	97,27	8,50	9,2	5200	40000	19400
9559	111,67	8,50	8,1	5200	40000	19400
10013	122,57	8,11	7,3	5200	40000	19400
9599	139,21	6,84	6,5	5200	40000	19400
7485	154,02	4,82	5,8	5200	40000	19400
8489	160,02	5,27	5,6	5200	40000	19400
8593	176,81	4,82	5,1	5200	40000	19400
9431	194,06	4,82	4,6	5200	40000	19400
9821	220,42	4,42	4,1	5200	40000	19400
8693	253,36	3,41	3,5	5200	40000	19400

IS052

Mn ₂ [Nm]	i	Pn ₁ [kW]	n ₂ [rpm]	Fr1 [N]	Fr2 D [N]	Fr2 C-L [N]
181	8,63	1,58	81,2	674	4435	4435
202	11,14	1,36	62,8	773	4795	4795
213	12,00	1,33	58,3	787	4881	4881
223	13,66	1,23	51,3	835	5086	5086
255	15,27	1,26	45,8	823	5141	5141
255	16,29	1,18	43,0	859	5283	5283
255	18,63	1,03	37,6	928	5590	5590
255	19,73	0,97	35,5	955	5725	5725
276	21,04	0,99	33,3	947	5756	5756
276	21,53	0,97	32,5	958	5812	5812
276	24,07	0,86	29,1	1005	6000	6000
308	25,20	0,92	27,8	979	6000	6000
308	25,79	0,90	27,1	989	6000	6000
308	27,81	0,83	25,2	1019	6000	6000
308	30,00	0,77	23,3	1047	6000	6000
319	32,55	0,74	21,5	1064	6000	6000
319	33,00	0,73	21,2	1069	6000	6000
319	34,09	0,70	20,5	1080	6000	6000
351	36,55	0,72	19,1	1071	6000	6000
351	38,75	0,68	18,1	1090	6000	6000
372	39,90	0,70	17,5	1081	6000	6000
372	42,63	0,66	16,4	1101	6000	6000
372	46,00	0,61	15,2	1124	6000	6000
372	47,20	0,59	14,8	1131	6000	6000
372	52,25	0,54	13,4	1158	6000	6000
372	57,86	0,48	12,1	1182	6000	6000
372	59,42	0,47	11,8	1188	6000	6000
372	72,83	0,38	9,6	1228	6000	6000

IS053

Mn ₂ [Nm]	i	Pn ₁ [kW]	n ₂ [rpm]	Fr1 [N]	Fr2 D [N]	Fr2 C-L [N]
372	36,50	0,78	19,2	1050	6000	6000
372	47,14	0,61	14,8	1131	6000	6000
372	57,79	0,49	12,1	1181	6000	6000
372	63,74	0,45	11,0	1203	6000	6000
372	74,20	0,39	9,4	1231	6000	6000
372	78,14	0,37	9,0	1240	6000	6000
372	95,84	0,30	7,3	1271	6000	6000
372	117,48	0,24	6,0	1296	6000	6000
372	137,45	0,21	5,1	1312	6000	6000
372	177,55	0,16	3,9	1333	6000	6000

IS053

Mn ₂ [Nm]	i	Pn ₁ [kW]	n ₂ [rpm]	Fr1 [N]	Fr2 D [N]	Fr2 C-L [N]
372	198,45	0,14	3,5	1341	6000	6000
372	217,64	0,13	3,2	1347	6000	6000
372	256,33	0,11	2,7	1356	6000	6000
372	314,21	0,09	2,2	1365	6000	6000

IS062

Mn ₂ [Nm]	i	Pn ₁ [kW]	n ₂ [rpm]	Fr1 [N]	Fr2 D [N]	Fr2 C-L [N]
351	8,00	3,30	87,5	284	6975	2790
351	8,92	2,96	78,5	400	7312	2925
383	9,55	3,01	73,3	380	7325	2930
383	10,65	2,70	65,8	486	7683	3073
414	11,71	2,66	59,8	500	7803	3121
446	13,06	2,57	53,6	531	7983	3193
446	13,36	2,51	52,4	551	8065	3226
478	15,94	2,26	43,9	639	8516	3407
478	16,16	2,23	43,3	649	8570	3428
478	19,29	1,86	36,3	772	9266	3706
489	19,55	1,88	35,8	767	9254	3702
499	23,18	1,62	30,2	856	9901	3960
499	23,75	1,58	29,5	869	10000	4000
510	25,14	1,53	27,8	888	10000	4000
510	27,66	1,39	25,3	935	10000	4000
531	30,00	1,33	23,3	954	10000	4000
574	33,93	1,27	20,6	975	10000	4000
638	36,57	1,31	19,1	961	10000	4000
638	39,38	1,22	17,8	993	10000	4000
638	43,64	1,10	16,0	1034	10000	4000
638	46,10	1,04	15,2	1054	10000	4000
638	48,30	0,99	14,5	1070	10000	4000
638	53,53	0,90	13,1	1103	10000	4000
638	55,00	0,87	12,7	1111	10000	4000
638	67,47	0,71	10,4	1166	10000	4000

IS063

Mn ₂ [Nm]	i	Pn ₁ [kW]	n ₂ [rpm]	Fr1 [N]	Fr2 D [N]	Fr2 C-L [N]
638	33,57	1,46	20,9	921	10000	4000
638	37,77	1,30	18,5	976	10000	4000
638	40,05	1,22	17,5	1000	10000	4000
638	49,13	1,00	14,2	1076	10000	4000

IS063

Mn ₂ [Nm]	i	Pn ₁ [kW]	n ₂ [rpm]	Fr1 [N]	Fr2 D [N]	Fr2 C-L [N]
638	55,29	0,89	12,7	1113	10000	4000
638	58,72	0,83	11,9	1130	10000	4000
638	65,85	0,74	10,6	1160	10000	4000
638	68,25	0,72	10,3	1169	10000	4000
638	73,63	0,67	9,5	1187	10000	4000
638	81,43	0,60	8,6	1208	10000	4000
638	99,89	0,49	7,0	1245	10000	4000
638	126,43	0,39	5,5	1279	10000	4000
638	150,85	0,32	4,6	1300	10000	4000
638	182,53	0,27	3,8	1319	10000	4000
638	185,05	0,26	3,8	1320	10000	4000
638	217,79	0,22	3,2	1334	10000	4000
638	267,16	0,18	2,6	1348	10000	4000

IS082

Mn ₂ [Nm]	i	Pn ₁ [kW]	n ₂ [rpm]	Fr1 [N]	Fr2 D [N]	Fr2 C-L [N]
584	7,34	5,99	95,4	1153	15474	4421
638	8,06	5,95	86,8	1166	15847	4528
691	9,94	5,22	70,4	1388	16959	4845
744	11,61	4,82	60,3	1511	17790	5083
797	12,75	4,70	54,9	1548	18000	5215
808	14,04	4,33	49,8	1663	18000	5399
818	15,43	3,99	45,4	1766	18000	5583
818	15,73	3,91	44,5	1789	18000	5623
818	17,29	3,56	40,5	1898	18000	5826
818	19,03	3,23	36,8	1997	18000	6038
818	20,14	3,06	34,8	2052	18000	6166
850	22,13	2,89	31,6	2102	18000	6355
850	24,00	2,66	29,2	2171	18000	6550
850	26,05	2,45	26,9	2236	18000	6751
956	27,29	2,64	25,6	2180	18000	6768
956	28,67	2,51	24,4	2219	18000	6894
956	29,60	2,43	23,6	2243	18000	6976
1063	31,78	2,52	22,0	2217	18000	7063
1063	34,91	2,29	20,1	2286	18000	7200
1063	35,50	2,25	19,7	2298	18000	7200
1063	40,05	2,00	17,5	2376	18000	7200
1063	43,05	1,86	16,3	2419	18000	7200
1063	50,25	1,59	13,9	2500	18000	7200
1063	54,27	1,47	12,9	2536	18000	7200
1063	61,98	1,29	11,3	2592	18000	7200

IS083

Mn ₂ [Nm]	i	Pn ₁ [kW]	n ₂ [rpm]	Fr1 [N]	Fr2 D [N]	Fr2 C-L [N]
1063	67,52	1,21	10,4	2625	18000	7200
1063	74,18	1,10	9,4	2657	18000	7200
1063	81,71	1,00	8,6	2688	18000	7200
1063	91,49	0,89	7,7	2720	18000	7200
1063	100,62	0,81	7,0	2744	18000	7200
1063	117,17	0,70	6,0	2778	18000	7200
1063	128,73	0,63	5,4	2797	18000	7200
1063	136,34	0,60	5,1	2808	18000	7200
1063	158,76	0,51	4,4	2833	18000	7200
1063	184,88	0,44	3,8	2855	18000	7200
1063	203,11	0,40	3,5	2867	18000	7200
1063	205,34	0,40	3,4	2868	18000	7200
1063	226,04	0,36	3,1	2879	18000	7200
1063	250,50	0,33	2,8	2889	18000	7200
1063	266,13	0,31	2,6	2895	18000	7200
1063	292,36	0,28	2,4	2903	18000	7200
1063	315,73	0,26	2,2	2910	18000	7200
1063	360,58	0,23	1,9	2919	18000	7200

IS102

Mn ₂ [Nm]	i	Pn ₁ [kW]	n ₂ [rpm]	Fr1 [N]	Fr2 D [N]	Fr2 C-L [N]
903	8,06	8,43	86,8	501	19490	5569
956	8,85	8,13	79,1	588	20031	5723
1009	10,88	6,98	64,3	929	21487	6139
1063	12,75	6,27	54,9	1138	22000	6469
1275	13,99	6,86	50,0	964	22000	6537
1328	15,43	6,48	45,4	1077	22000	6743
1381	17,21	6,04	40,7	1206	22000	6988
1488	19,00	5,89	36,8	1250	22000	7175
1488	20,83	5,37	33,6	1403	22000	7430
1488	22,13	5,06	31,6	1495	22000	7601
1594	24,28	4,94	28,8	1531	22000	7793
1594	26,33	4,55	26,6	1645	22000	8037
1594	29,87	4,01	23,4	1804	22000	8429
1594	32,40	3,70	21,6	1896	22000	8690
1488	34,91	3,21	20,1	2042	22000	9000
1594	38,30	3,13	18,3	2065	22000	9000
1488	42,53	2,63	16,5	2212	22000	9000
1381	44,00	2,36	15,9	2292	22000	9000
1700	47,13	2,71	14,8	2188	22000	9000
1488	50,25	2,23	13,9	2331	22000	9000

IS102

Mn ₂ [Nm]	i	Pn ₁ [kW]	n ₂ [rpm]	Fr1 [N]	Fr2 D [N]	Fr2 C-L [N]
1381	55,14	1,88	12,7	2432	22000	9000
1700	59,40	2,15	11,8	2353	22000	9000
1700	67,84	1,89	10,3	2432	22000	9000

IS103

Mn ₂ [Nm]	i	Pn ₁ [kW]	n ₂ [rpm]	Fr1 [N]	Fr2 D [N]	Fr2 C-L [N]
1700	74,18	1,76	9,4	2480	22000	9000
1700	81,39	1,60	8,6	2525	22000	9000
1700	89,77	1,45	7,8	2568	22000	9000
1700	100,15	1,30	7,0	2612	22000	9000
1700	110,55	1,18	6,3	2647	22000	9000
1700	121,29	1,08	5,8	2678	22000	9000
1700	128,73	1,01	5,4	2696	22000	9000
1700	141,24	0,92	5,0	2722	22000	9000
1700	173,78	0,75	4,0	2772	22000	9000
1700	188,51	0,69	3,7	2789	22000	9000
1700	203,11	0,64	3,5	2803	22000	9000
1700	222,85	0,59	3,1	2819	22000	9000
1700	224,76	0,58	3,1	2821	22000	9000
1700	274,20	0,48	2,5	2851	22000	9000
1700	280,89	0,46	2,5	2854	22000	9000
1700	292,36	0,45	2,4	2860	22000	9000
1700	320,79	0,41	2,2	2871	22000	9000
1700	345,60	0,38	2,0	2880	22000	9000
1700	394,69	0,33	1,8	2893	22000	9000

IS122

Mn ₂ [Nm]	i	Pn ₁ [kW]	n ₂ [rpm]	Fr1 [N]	Fr2 D [N]	Fr2 C-L [N]
1594	8,48	14,13	82,5	2887	25726	7350
1806	9,30	14,61	75,3	2851	25898	7399
1806	10,24	13,27	68,4	2953	26956	7702
2019	11,42	13,30	61,3	2951	27388	7825
2338	12,63	13,93	55,4	2903	27364	7818
2550	13,84	13,86	50,6	2908	27673	7906
2763	16,99	12,23	41,2	3033	29485	8424
2975	21,25	10,53	32,9	3162	30000	9068
2975	22,37	10,01	31,3	3202	30000	9278
3081	23,29	9,95	30,1	3206	30000	9331
3188	26,15	9,17	26,8	3266	30000	9710

IS122

Mn ₂ [Nm]	i	Pn ₁ [kW]	n ₂ [rpm]	Fr1 [N]	Fr2 D [N]	Fr2 C-L [N]
3188	28,60	8,38	24,5	3326	30000	10104
3188	30,51	7,86	22,9	3366	30000	10396
3188	32,76	7,32	21,4	3407	30000	10724
3188	33,44	7,17	20,9	3419	30000	10822
3188	35,20	6,81	19,9	3446	30000	11065
3188	41,07	5,84	17,1	3520	30000	11200
3188	43,60	5,50	16,1	3546	30000	11200
2550	44,63	4,30	15,7	3638	30000	11200
2550	49,04	3,91	14,3	3667	30000	11200
2763	53,75	3,87	13,0	3671	30000	11200
3188	66,00	3,63	10,6	3688	30000	11200

IS123

Mn ₂ [Nm]	i	Pn ₁ [kW]	n ₂ [rpm]	Fr1 [N]	Fr2 D [N]	Fr2 C-L [N]
2869	64,84	3,40	10,8	3712	30000	11200
2869	71,07	3,10	9,8	3734	30000	11200
3188	78,46	3,12	8,9	3732	30000	11200
3188	87,27	2,81	8,0	3756	30000	11200
3188	105,91	2,31	6,6	3793	30000	11200
3188	112,52	2,18	6,2	3803	30000	11200
3188	123,33	1,99	5,7	3817	30000	11200
3188	130,04	1,88	5,4	3825	30000	11200
3188	133,78	1,83	5,2	3829	30000	11200
3188	151,43	1,62	4,6	3845	30000	11200
3188	177,53	1,38	3,9	3863	30000	11200
3188	194,59	1,26	3,6	3872	30000	11200
3188	215,60	1,14	3,2	3881	30000	11200
3188	238,93	1,02	2,9	3889	30000	11200

IS142

Mn ₂ [Nm]	i	Pn ₁ [kW]	n ₂ [rpm]	Fr1 [N]	Fr2 D [N]	Fr2 C-L [N]
1476	4,12	26,96	170,0	2243	28216	16124
1645	4,59	26,98	152,6	2241	28326	16186
1846	5,14	27,00	136,1	2239	28334	16191
2087	5,82	26,97	120,3	2241	28218	16125
2230	6,21	27,00	112,7	2239	28061	16035
2035	7,32	20,92	95,7	2836	32133	18362
2283	8,21	20,92	85,3	2836	32039	18308
2584	9,29	20,93	75,4	2835	31747	18141

IS142

Mn ₂ [Nm]	i	Pn ₁ [kW]	n ₂ [rpm]	Fr1 [N]	Fr2 D [N]	Fr2 C-L [N]
2759	9,91	20,94	70,6	2835	31503	18002
2992	11,41	19,73	61,4	2953	32189	18394
2784	12,81	16,34	54,6	3286	35000	18500
2593	14,27	13,67	49,0	3549	35000	18500
2818	16,01	13,24	43,7	3591	35000	18500
3187	18,11	13,24	38,7	3591	35000	18500
3404	19,33	13,24	36,2	3591	35000	18500
3522	22,24	11,91	31,5	3722	35000	18500
3077	25,26	9,16	27,7	3992	35000	18500
3451	28,33	9,16	24,7	3992	35000	18500
3904	32,05	9,16	21,8	3992	35000	18500
4168	34,22	9,16	20,4	3992	35000	18500
4708	39,38	8,99	17,8	4009	35000	18500

IS143

Mn ₂ [Nm]	i	Pn ₁ [kW]	n ₂ [rpm]	Fr1 [N]	Fr2 D [N]	Fr2 C-L [N]
4264	45,77	7,16	15,3	4200	35000	18500
4749	50,97	7,16	13,7	4200	35000	18500
5030	57,17	6,76	12,2	4200	35000	18500
5073	64,68	6,03	10,8	4200	35000	18500
5181	69,06	5,76	10,1	4200	35000	18500
4498	79,45	4,35	8,8	4200	35000	18500
4717	98,81	3,67	7,1	4200	35000	18500
5029	110,05	3,51	6,4	4200	35000	18500
5052	123,44	3,14	5,7	4200	35000	18500
5143	139,64	2,83	5,0	4200	35000	18500
5085	149,10	2,62	4,7	4200	35000	18500
4039	157,49	1,97	4,4	4200	35000	18500
4961	171,55	2,22	4,1	4200	35000	18500
4499	175,41	1,97	4,0	4200	35000	18500
5046	196,74	1,97	3,6	4200	35000	18500
5010	222,57	1,73	3,1	4200	35000	18500
5187	237,63	1,68	3,0	4200	35000	18500
5091	273,41	1,43	2,6	4200	35000	18500

IS152

Mn ₂ [Nm]	i	Pn ₁ [kW]	n ₂ [rpm]	Fr1 [N]	Fr2 D [N]	Fr2 C-L [N]
2734	4,06	50,64	172,3	2623	34097	19400
3051	4,53	50,62	154,4	2624	34289	19400

IS152

Mn ₂ [Nm]	i	Pn ₁ [kW]	n ₂ [rpm]	Fr1 [N]	Fr2 D [N]	Fr2 C-L [N]
3096	5,20	44,76	134,5	2974	36364	19400
3126	5,71	41,17	122,6	3188	37829	19400
3267	6,52	37,68	107,3	3396	39518	19400
3463	7,28	35,78	96,2	3510	40000	19400
3752	8,36	33,77	83,8	3630	40000	19400
3985	9,17	32,68	76,3	3694	40000	19400
4443	10,42	32,08	67,2	3730	40000	19400
3512	12,46	21,20	56,2	4380	40000	19400
3918	13,91	21,19	50,3	4380	40000	19400
4499	15,97	21,19	43,8	4380	40000	19400
4939	17,53	21,20	39,9	4380	40000	19400
5610	19,91	21,20	35,2	4380	40000	19400
6450	22,88	21,20	30,6	4379	40000	19400
6470	27,11	17,96	25,8	4573	40000	19400
7102	29,75	17,96	23,5	4573	40000	19400
8067	33,79	17,96	20,7	4573	40000	19400
8170	38,84	15,82	18,0	4700	40000	19400

IS153

Mn ₂ [Nm]	i	Pn ₁ [kW]	n ₂ [rpm]	Fr1 [N]	Fr2 D [N]	Fr2 C-L [N]
6674	40,10	12,79	17,5	4897	40000	19400
7448	44,76	12,78	15,6	4898	40000	19400
8357	51,38	12,50	13,6	4914	40000	19400
8770	56,39	11,95	12,4	4946	40000	19400
9345	64,05	11,21	10,9	4990	40000	19400
8266	73,63	8,62	9,5	5141	40000	19400
7550	87,16	6,65	8,0	5200	40000	19400
8426	97,27	6,65	7,2	5200	40000	19400
9673	111,67	6,65	6,3	5200	40000	19400
10132	122,57	6,35	5,7	5200	40000	19400
9713	139,21	5,36	5,0	5200	40000	19400
7574	154,02	3,78	4,5	5200	40000	19400
8590	160,02	4,12	4,4	5200	40000	19400
8695	176,81	3,78	4,0	5200	40000	19400
9543	194,06	3,78	3,6	5200	40000	19400
9938	220,42	3,46	3,2	5200	40000	19400
8796	253,36	2,67	2,8	5200	40000	19400

IS052

Mn ₂ [Nm]	i	Pn ₁ [kW]	n ₂ [rpm]	Fr1 [N]	Fr2 D [N]	Fr2 C-L [N]
183	8,63	1,13	58,0	666	5067	5067
204	11,14	0,98	44,9	766	5482	5482
215	12,00	0,96	41,7	780	5585	5585
226	13,66	0,88	36,6	829	5820	5820
258	15,27	0,90	32,7	816	5901	5901
258	16,29	0,85	30,7	853	6000	6000
258	18,63	0,74	26,8	922	6000	6000
258	19,73	0,70	25,4	949	6000	6000
280	21,04	0,71	23,8	942	6000	6000
280	21,53	0,69	23,2	953	6000	6000
280	24,07	0,62	20,8	1000	6000	6000
312	25,20	0,66	19,8	974	6000	6000
312	25,79	0,65	19,4	984	6000	6000
312	27,81	0,60	18,0	1015	6000	6000
312	30,00	0,56	16,7	1043	6000	6000
323	32,55	0,53	15,4	1060	6000	6000
323	33,00	0,52	15,2	1065	6000	6000
323	34,09	0,51	14,7	1076	6000	6000
355	36,55	0,52	13,7	1067	6000	6000
355	38,75	0,49	12,9	1086	6000	6000
376	39,90	0,50	12,5	1077	6000	6000
376	42,63	0,47	11,7	1098	6000	6000
376	46,00	0,44	10,9	1121	6000	6000
376	47,20	0,43	10,6	1128	6000	6000
376	52,25	0,39	9,6	1155	6000	6000
376	57,86	0,35	8,6	1179	6000	6000
376	59,42	0,34	8,4	1185	6000	6000
376	72,83	0,28	6,9	1226	6000	6000

IS053

Mn ₂ [Nm]	i	Pn ₁ [kW]	n ₂ [rpm]	Fr1 [N]	Fr2 D [N]	Fr2 C-L [N]
376	36,50	0,56	13,7	1046	6000	6000
376	47,14	0,44	10,6	1127	6000	6000
376	57,79	0,36	8,7	1179	6000	6000
376	63,74	0,32	7,8	1200	6000	6000
376	74,20	0,28	6,7	1229	6000	6000
376	78,14	0,26	6,4	1238	6000	6000
376	95,84	0,21	5,2	1269	6000	6000
376	117,48	0,17	4,3	1294	6000	6000
376	137,45	0,15	3,6	1311	6000	6000
376	177,55	0,12	2,8	1332	6000	6000

IS053

Mn ₂ [Nm]	i	Pn ₁ [kW]	n ₂ [rpm]	Fr1 [N]	Fr2 D [N]	Fr2 C-L [N]
376	198,45	0,10	2,5	1340	6000	6000
376	217,64	0,09	2,3	1346	6000	6000
376	256,33	0,08	1,9	1355	6000	6000
376	314,21	0,07	1,6	1365	6000	6000

IS062

Mn ₂ [Nm]	i	Pn ₁ [kW]	n ₂ [rpm]	Fr1 [N]	Fr2 D [N]	Fr2 C-L [N]
355	8,00	2,37	62,5	270	8029	3212
355	8,92	2,13	56,0	388	8406	3362
387	9,55	2,17	52,4	368	8442	3377
387	10,65	1,94	47,0	475	8841	3536
419	11,71	1,91	42,7	490	8997	3599
452	13,06	1,85	38,3	521	9220	3688
452	13,36	1,81	37,4	541	9310	3724
484	15,94	1,62	31,4	630	9837	3935
484	16,16	1,60	30,9	640	9897	3959
484	19,29	1,34	25,9	765	10000	4000
495	19,55	1,35	25,6	759	10000	4000
505	23,18	1,17	21,6	849	10000	4000
505	23,75	1,14	21,1	863	10000	4000
516	25,14	1,10	19,9	882	10000	4000
516	27,66	1,00	18,1	930	10000	4000
538	30,00	0,96	16,7	949	10000	4000
581	33,93	0,91	14,7	970	10000	4000
645	36,57	0,94	13,7	956	10000	4000
645	39,38	0,88	12,7	988	10000	4000
645	43,64	0,79	11,5	1029	10000	4000
645	46,10	0,75	10,8	1050	10000	4000
645	48,30	0,71	10,3	1066	10000	4000
645	53,53	0,64	9,3	1100	10000	4000
645	55,00	0,63	9,1	1108	10000	4000
645	67,47	0,51	7,4	1163	10000	4000

IS063

Mn ₂ [Nm]	i	Pn ₁ [kW]	n ₂ [rpm]	Fr1 [N]	Fr2 D [N]	Fr2 C-L [N]
645	33,57	1,05	14,9	916	10000	4000
645	37,77	0,93	13,2	970	10000	4000
645	40,05	0,88	12,5	995	10000	4000
645	49,13	0,72	10,2	1072	10000	4000

IS063

Mn ₂ [Nm]	i	Pn ₁ [kW]	n ₂ [rpm]	Fr1 [N]	Fr2 D [N]	Fr2 C-L [N]
645	55,29	0,64	9,0	1109	10000	4000
645	58,72	0,60	8,5	1127	10000	4000
645	65,85	0,53	7,6	1157	10000	4000
645	68,25	0,52	7,3	1166	10000	4000
645	73,63	0,48	6,8	1184	10000	4000
645	81,43	0,43	6,1	1206	10000	4000
645	99,89	0,35	5,0	1243	10000	4000
645	126,43	0,28	4,0	1278	10000	4000
645	150,85	0,23	3,3	1299	10000	4000
645	182,53	0,19	2,7	1318	10000	4000
645	185,05	0,19	2,7	1319	10000	4000
645	217,79	0,16	2,3	1333	10000	4000
645	267,16	0,13	1,9	1347	10000	4000

IS082

Mn ₂ [Nm]	i	Pn ₁ [kW]	n ₂ [rpm]	Fr1 [N]	Fr2 D [N]	Fr2 C-L [N]
591	7,34	4,31	68,1	1132	17494	4998
645	8,06	4,28	62,0	1145	17930	5123
699	9,94	3,76	50,3	1369	18000	5483
753	11,61	3,47	43,1	1494	18000	5754
806	12,75	3,38	39,2	1531	18000	5907
817	14,04	3,11	35,6	1647	18000	6113
828	15,43	2,87	32,4	1752	18000	6319
828	15,73	2,81	31,8	1775	18000	6364
828	17,29	2,56	28,9	1885	18000	6592
828	19,03	2,33	26,3	1985	18000	6828
828	20,14	2,20	24,8	2041	18000	6972
860	22,13	2,08	22,6	2092	18000	7186
860	24,00	1,92	20,8	2162	18000	7200
860	26,05	1,77	19,2	2227	18000	7200
968	27,29	1,90	18,3	2171	18000	7200
968	28,67	1,80	17,4	2210	18000	7200
968	29,60	1,75	16,9	2234	18000	7200
1075	31,78	1,81	15,7	2208	18000	7200
1075	34,91	1,65	14,3	2278	18000	7200
1075	35,50	1,62	14,1	2290	18000	7200
1075	40,05	1,44	12,5	2369	18000	7200
1075	43,05	1,34	11,6	2412	18000	7200
1075	50,25	1,14	9,9	2494	18000	7200
1075	54,27	1,06	9,2	2531	18000	7200
1075	61,98	0,93	8,1	2588	18000	7200

IS083

Mn ₂ [Nm]	i	Pn ₁ [kW]	n ₂ [rpm]	Fr1 [N]	Fr2 D [N]	Fr2 C-L [N]
1075	67,52	0,87	7,4	2620	18000	7200
1075	74,18	0,79	6,7	2653	18000	7200
1075	81,71	0,72	6,1	2684	18000	7200
1075	91,49	0,64	5,5	2717	18000	7200
1075	100,62	0,58	5,0	2741	18000	7200
1075	117,17	0,50	4,3	2776	18000	7200
1075	128,73	0,46	3,9	2795	18000	7200
1075	136,34	0,43	3,7	2806	18000	7200
1075	158,76	0,37	3,1	2831	18000	7200
1075	184,88	0,32	2,7	2853	18000	7200
1075	203,11	0,29	2,5	2865	18000	7200
1075	205,34	0,29	2,4	2867	18000	7200
1075	226,04	0,26	2,2	2878	18000	7200
1075	250,50	0,23	2,0	2888	18000	7200
1075	266,13	0,22	1,9	2894	18000	7200
1075	292,36	0,20	1,7	2902	18000	7200
1075	315,73	0,19	1,6	2909	18000	7200
1075	360,58	0,16	1,4	2918	18000	7200

IS102

Mn ₂ [Nm]	i	Pn ₁ [kW]	n ₂ [rpm]	Fr1 [N]	Fr2 D [N]	Fr2 C-L [N]
914	8,06	6,06	62,0	471	22000	6293
968	8,85	5,85	56,5	560	22000	6470
1021	10,88	5,02	45,9	905	22000	6939
1075	12,75	4,51	39,2	1116	22000	7312
1290	13,99	4,93	35,7	941	22000	7405
1344	15,43	4,66	32,4	1054	22000	7639
1398	17,21	4,34	29,1	1185	22000	7917
1505	19,00	4,24	26,3	1229	22000	8134
1505	20,83	3,86	24,0	1384	22000	8419
1505	22,13	3,64	22,6	1478	22000	8611
1613	24,28	3,55	20,6	1513	22000	8833
1613	26,33	3,27	19,0	1629	22000	9000
1613	29,87	2,89	16,7	1790	22000	9000
1613	32,40	2,66	15,4	1883	22000	9000
1505	34,91	2,31	14,3	2031	22000	9000
1613	38,30	2,25	13,1	2054	22000	9000
1505	42,53	1,89	11,8	2203	22000	9000
1398	44,00	1,70	11,4	2283	22000	9000
1720	47,13	1,95	10,6	2178	22000	9000
1505	50,25	1,60	9,9	2324	22000	9000

IS102

Mn ₂ [Nm]	i	Pn ₁ [kW]	n ₂ [rpm]	Fr1 [N]	Fr2 D [N]	Fr2 C-L [N]
1398	55,14	1,36	9,1	2426	22000	9000
1720	59,40	1,55	8,4	2346	22000	9000
1720	67,84	1,36	7,4	2426	22000	9000

IS103

Mn ₂ [Nm]	i	Pn ₁ [kW]	n ₂ [rpm]	Fr1 [N]	Fr2 D [N]	Fr2 C-L [N]
1720	74,18	1,27	6,7	2474	22000	9000
1720	81,39	1,15	6,1	2520	22000	9000
1720	89,77	1,05	5,6	2563	22000	9000
1720	100,15	0,94	5,0	2607	22000	9000
1720	110,55	0,85	4,5	2643	22000	9000
1720	121,29	0,77	4,1	2674	22000	9000
1720	128,73	0,73	3,9	2692	22000	9000
1720	141,24	0,66	3,5	2718	22000	9000
1720	173,78	0,54	2,9	2769	22000	9000
1720	188,51	0,50	2,6	2786	22000	9000
1720	203,11	0,46	2,5	2801	22000	9000
1720	222,85	0,42	2,2	2817	22000	9000
1720	224,76	0,42	2,2	2819	22000	9000
1720	274,20	0,34	1,8	2850	22000	9000
1720	280,89	0,33	1,8	2853	22000	9000
1720	292,36	0,32	1,7	2858	22000	9000
1720	320,79	0,29	1,6	2870	22000	9000
1720	345,60	0,27	1,4	2878	22000	9000
1720	394,69	0,24	1,3	2892	22000	9000

IS122

Mn ₂ [Nm]	i	Pn ₁ [kW]	n ₂ [rpm]	Fr1 [N]	Fr2 D [N]	Fr2 C-L [N]
1613	8,48	10,16	59,0	2875	29386	8396
1828	9,30	10,51	53,8	2838	29662	8475
1828	10,24	9,54	48,8	2941	30000	8813
2043	11,42	9,57	43,8	2939	30000	8975
2365	12,63	10,02	39,6	2891	30000	9004
2580	13,84	9,97	36,1	2896	30000	9127
2795	16,99	8,79	29,4	3022	30000	9729
3010	21,25	7,57	23,5	3153	30000	10473
3010	22,37	7,20	22,4	3193	30000	10707
3118	23,29	7,16	21,5	3197	30000	10779
3225	26,15	6,59	19,1	3258	30000	11200

IS122

Mn ₂ [Nm]	i	Pn ₁ [kW]	n ₂ [rpm]	Fr1 [N]	Fr2 D [N]	Fr2 C-L [N]
3225	28,60	6,03	17,5	3318	30000	11200
3225	30,51	5,65	16,4	3359	30000	11200
3225	32,76	5,26	15,3	3401	30000	11200
3225	33,44	5,16	14,9	3412	30000	11200
3225	35,20	4,90	14,2	3440	30000	11200
3225	41,07	4,20	12,2	3515	30000	11200
3225	43,60	3,96	11,5	3541	30000	11200
2580	44,63	3,09	11,2	3634	30000	11200
2580	49,04	2,81	10,2	3664	30000	11200
2795	53,75	2,78	9,3	3667	30000	11200
3225	66,00	2,61	7,6	3685	30000	11200

IS123

Mn ₂ [Nm]	i	Pn ₁ [kW]	n ₂ [rpm]	Fr1 [N]	Fr2 D [N]	Fr2 C-L [N]
2903	64,84	2,44	7,7	3709	30000	11200
2903	71,07	2,23	7,0	3731	30000	11200
3225	78,46	2,24	6,4	3730	30000	11200
3225	87,27	2,02	5,7	3753	30000	11200
3225	105,91	1,66	4,7	3791	30000	11200
3225	112,52	1,57	4,4	3801	30000	11200
3225	123,33	1,43	4,0	3815	30000	11200
3225	130,04	1,35	3,8	3823	30000	11200
3225	133,78	1,32	3,7	3827	30000	11200
3225	151,43	1,16	3,3	3843	30000	11200
3225	177,53	0,99	2,8	3861	30000	11200
3225	194,59	0,91	2,6	3870	30000	11200
3225	215,60	0,82	2,3	3880	30000	11200
3225	238,93	0,74	2,1	3888	30000	11200

IS142

Mn ₂ [Nm]	i	Pn ₁ [kW]	n ₂ [rpm]	Fr1 [N]	Fr2 D [N]	Fr2 C-L [N]
1493	4,12	19,39	121,4	2211	32760	18500
1664	4,59	19,40	109,0	2210	33023	18500
1868	5,14	19,41	97,2	2208	33200	18500
2111	5,82	19,40	85,9	2210	33271	18500
2257	6,21	19,42	80,5	2207	33215	18500
2059	7,32	15,05	68,3	2812	35000	18500
2310	8,21	15,05	60,9	2812	35000	18500
2614	9,29	15,05	53,9	2811	35000	18500

IS142

Mn_2 [Nm]	i	Pn_1 [kW]	n2 [rpm]	Fr1 [N]	Fr2 D [N]	Fr2 C-L [N]
2791	9,91	15,06	50,4	2811	35000	18500
3027	11,41	14,19	43,8	2930	35000	18500
2817	12,81	11,75	39,0	3267	35000	18500
2623	14,27	9,83	35,0	3534	35000	18500
2851	16,01	9,52	31,2	3576	35000	18500
3225	18,11	9,52	27,6	3576	35000	18500
3444	19,33	9,52	25,9	3576	35000	18500
3564	22,24	8,57	22,5	3708	35000	18500
3113	25,26	6,59	19,8	3981	35000	18500
3491	28,33	6,59	17,6	3982	35000	18500
3950	32,05	6,59	15,6	3982	35000	18500
4217	34,22	6,59	14,6	3982	35000	18500
4763	39,38	6,47	12,7	3998	35000	18500

IS143

Mn_2 [Nm]	i	Pn_1 [kW]	n2 [rpm]	Fr1 [N]	Fr2 D [N]	Fr2 C-L [N]
4314	45,77	5,15	10,9	4196	35000	18500
4805	50,97	5,15	9,8	4196	35000	18500
5090	57,17	4,86	8,8	4200	35000	18500
5133	64,68	4,33	7,7	4200	35000	18500
5242	69,06	4,15	7,2	4200	35000	18500
4551	79,45	3,13	6,3	4200	35000	18500
4773	98,81	2,64	5,1	4200	35000	18500
5089	110,05	2,52	4,5	4200	35000	18500
5111	123,44	2,26	4,0	4200	35000	18500
5204	139,64	2,03	3,6	4200	35000	18500
5145	149,10	1,88	3,4	4200	35000	18500
4086	157,49	1,42	3,2	4200	35000	18500
5020	171,55	1,60	2,9	4200	35000	18500
4551	175,41	1,42	2,9	4200	35000	18500
5105	196,74	1,42	2,5	4200	35000	18500
5069	222,57	1,24	2,2	4200	35000	18500
5248	237,63	1,21	2,1	4200	35000	18500
5151	273,41	1,03	1,8	4200	35000	18500

IS152

Mn_2 [Nm]	i	Pn_1 [kW]	n2 [rpm]	Fr1 [N]	Fr2 D [N]	Fr2 C-L [N]
2766	4,06	36,42	123,1	2588	39530	19400
3086	4,53	36,41	110,3	2588	39910	19400

IS152

Mn ₂ [Nm]	i	Pn ₁ [kW]	n ₂ [rpm]	Fr1 [N]	Fr2 D [N]	Fr2 C-L [N]
3133	5,20	32,19	96,1	2943	40000	19400
3163	5,71	29,61	87,5	3159	40000	19400
3306	6,52	27,10	76,7	3370	40000	19400
3503	7,28	25,73	68,7	3485	40000	19400
3796	8,36	24,28	59,8	3606	40000	19400
4032	9,17	23,50	54,5	3671	40000	19400
4496	10,42	23,07	48,0	3708	40000	19400
3554	12,46	15,25	40,1	4365	40000	19400
3964	13,91	15,24	36,0	4365	40000	19400
4552	15,97	15,24	31,3	4365	40000	19400
4997	17,53	15,24	28,5	4365	40000	19400
5676	19,91	15,24	25,1	4365	40000	19400
6526	22,88	15,25	21,9	4364	40000	19400
6546	27,11	12,91	18,4	4561	40000	19400
7186	29,75	12,91	16,8	4560	40000	19400
8162	33,79	12,91	14,8	4560	40000	19400
8266	38,84	11,38	12,9	4689	40000	19400

IS153

Mn ₂ [Nm]	i	Pn ₁ [kW]	n ₂ [rpm]	Fr1 [N]	Fr2 D [N]	Fr2 C-L [N]
6752	40,10	9,19	12,5	4889	40000	19400
7536	44,76	9,19	11,2	4889	40000	19400
8455	51,38	8,99	9,7	4906	40000	19400
8873	56,39	8,59	8,9	4938	40000	19400
9455	64,05	8,06	7,8	4982	40000	19400
8363	73,63	6,20	6,8	5135	40000	19400
7638	87,16	4,79	5,7	5200	40000	19400
8525	97,27	4,79	5,1	5200	40000	19400
9787	111,67	4,79	4,5	5200	40000	19400
10251	122,57	4,57	4,1	5200	40000	19400
9828	139,21	3,85	3,6	5200	40000	19400
7663	154,02	2,72	3,2	5200	40000	19400
8691	160,02	2,97	3,1	5200	40000	19400
8798	176,81	2,72	2,8	5200	40000	19400
9656	194,06	2,72	2,6	5200	40000	19400
10055	220,42	2,49	2,3	5200	40000	19400
8900	253,36	1,92	2,0	5200	40000	19400

ATTENTION!

The revised data and information, shown in this technical catalogue, replaces the data of the previous editions. Old data is now obsolete. All technical data, dimensions, weights in this catalogue are subject to changes without warning. Illustrations are not binding. You can find the above mentioned data and information on our site www.motovario.com; please periodically consult the technical documentation on the web site to be always updated about possible modifications of performances and characteristics of the product.

All supplies effected by MOTOVARIO are governed exclusively by the general terms of sale that you can find on our website:

<http://www.motovario.com/eng/corporate/sales-conditions>

